

TOOLS
HEADS
INCH
' 2 4



D'ANDREA®
TECHNOLOGY FOR HIGH PRECISION



Golden Compass
award for Industrial Design

EVOLUTION OF A LONG TRADITION

Made in Italy





Golden Compass award
for industrial design



D'ANDREA®
TECHNOLOGY FOR HIGH PRECISION

PRECISION IS OUR STRENGTH

D'ANDREA S.p.A., an Italian company, is a world leader in the production of high precision accessories for machine tools. D'Andrea was founded in 1951 by Marino D'Andrea, who started the business with the industry's first facing and boring head. The D'Andrea brand is recognized worldwide for the quality and reliability of its product and are available through a dealer network in over 40 countries.



D'Andrea Marino
The Founder



1951 - The first Head
for Boring and Facing

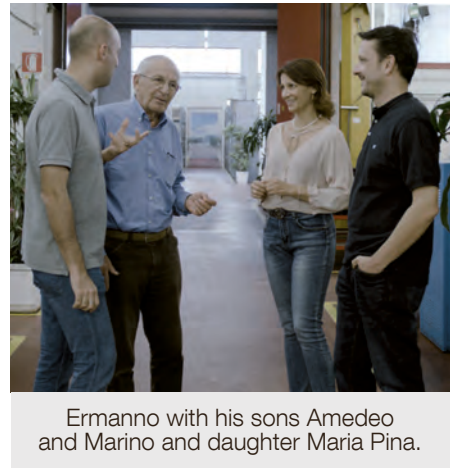

Ermanno with his sons Amedeo
and Marino and daughter Maria Pina.

A tradition of over 70 years in the manufacturing sector and a great passion for mechanics, which is now inherited by the third generation, with the aim of responding to the increasingly demanding requests from the world of precision mechanics. Every year significant resources are invested in the Research and Development of new products which, thanks to advanced technological solutions, satisfies a highly qualified demand.





Lainate (Milan)



D'Andrea S.p.A. represents the headquarters of the group, based in Lainate, a few kilometers from Milan. With over 7.000 sqm, D'Andrea boasts a modern, functioning and efficient plant where several machine tools are involved in the production of Tools and Heads. In particular, the grinding operations as well as the final test and assembly are here carried out.





Castel Del Giudice (Isernia)



D'Andrea Molise was founded in 2001 in Castel Del Giudice (Isernia), where Marino - the founder, was born. In this plant, most of the semi-finished products are made and, subsequently, finished, mounted and tested in the headquarters.



MHD'

MHD' 16 MHD' 20 MHD' 25 MHD' 32 MHD' 40 MHD' 50

ARBORS

8-11

DIN 69871



MAS403BT



HSK



PSC



ANSI/CAT



PR-RD-RAV-BMD

12

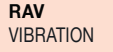

14-15

TS ROUGHING HEADS

16-22

TRM-TRE TESTAROSSA .00008 μm

TS 16/16
Ø .71 ~ .87



TS 20/20
Ø .87 ~ 1.10



TS 25/25
Ø 1.10 ~ 1.50



TS 32/32
Ø 1.40 ~ 1.97



TS 40/40
Ø 1.97 ~ 2.68



TS 50/50 - 50/63
Ø 2.68 ~ 4.72



TRM 16
Ø .71 ~ .91
INCH



TRM 20
Ø .87 ~ 1.14
INCH



TRM 25
Ø 1.10 ~ 1.50
INCH



TRM 32
Ø 1.40 ~ 2.03
INCH



TRM 40
Ø 1.89 ~ 2.48
INCH



TRM 50 INCH
Ø .10 ~ 5.51

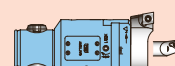
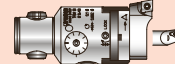

TRE 50 INCH
Ø .10 ~ 5.59

PSC

ARBORS

28

DIN 69871



PR-RD

29

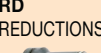

TS ROUGHING HEADS

30-31

PSC50 - TS50
Ø 2.68 ~ 3.54

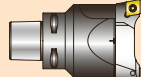

PSC 50

PSC63 - TS50
Ø 2.68 ~ 3.54

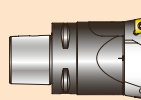

PSC 63

PSC63 - TS63
Ø 3.54 ~ 4.72

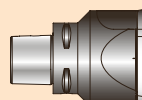

PSC63 - TS80
Ø 4.72 ~ 7.87

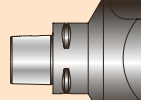

TRM TESTAROSSA .00008 μm

33-37

PSC50 - TRM50
Ø .10 ~ 5.51

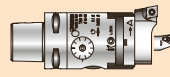

PSC63 - TRM50
Ø .10 ~ 5.51

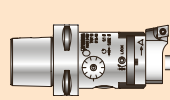

INCH

PSC63 - TRM63
Ø .10 ~ 6.10

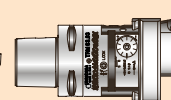

INCH

PSC63 - TRM80
Ø .10 ~ 8.66



INCH

U-TRONIC STANDARD

TESTE CN **58-65**

UT 3-360
Ø max 31.50

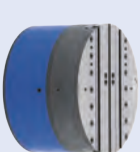

UT 5-500
Ø max 39.37

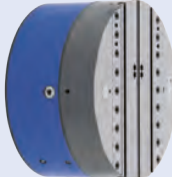

UT 5-630
Ø max 49.21

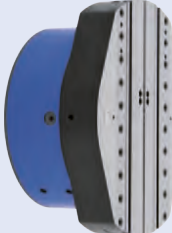

UT 5-800
Ø max 62.99

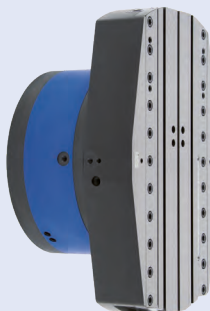

UT 8-800
Ø max 62.99

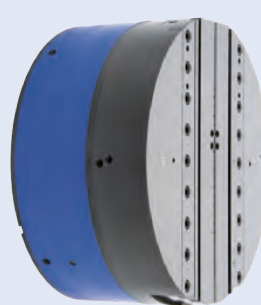

UT 8-1000
Ø max 78.74

UT 8-1250
Ø max 98.43

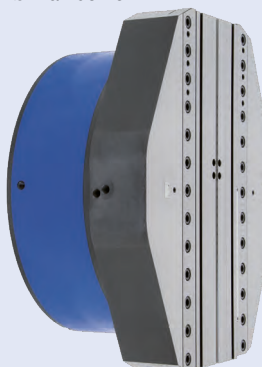

UT 8-1600
Ø max 125.98

BORING-MILLING MACHINES MEDIUM AND LARGE SIZES

TA-CENTER 2

TESTE CN

66-71

TA-C2.110
Ø max 7.87

TA-C2.170
Ø max 12.60

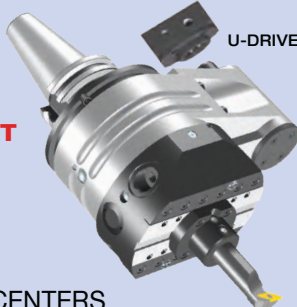

ARBORS HT

MACHINING CENTERS

TA-TRONIC 2

TESTE CN

72-73

TA-T2.110
Ø max 7.87

TA-T2.170
Ø max 12.60

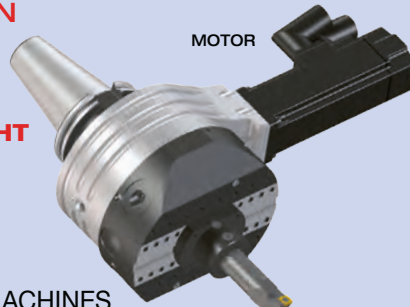

ATTACCO HT

MILLING MACHINES

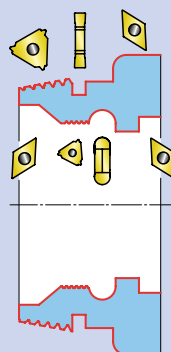

BACKWARD

23



INSERTS

44-45



TECHNICAL DATA

46-49

Painting



MHD' 63

TS 63/63
Ø 3.54 - 4.72

TS 80/80
Ø 4.72 - 7.87

MHD' 80

TS 80/90
Ø 6.30 - 9.84

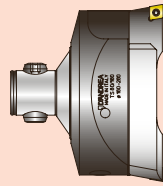
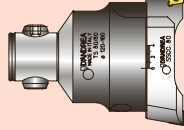
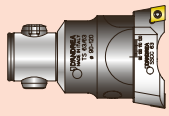

TRM 50/63 INCH
Ø .10 - 6.10

TRM 50/80 INCH
Ø .10 - 8.66

TRM 80/125 INCH
Ø 36 - 500

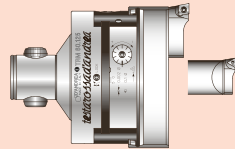

TRM 63/63 INCH
Ø .10 - 6.10

TRM 80/80 INCH
Ø .10 - 8.66

REDUCTIONS TO MHD' **29**

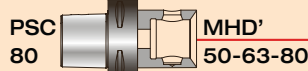
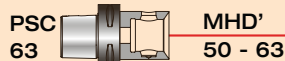
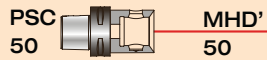

MILLING DRILLING **32**

ER COLLET CHUCKS

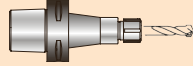

FORCE HIGH CLAMPING POWER

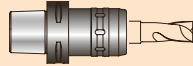

PF SHELL MILL HOLDERS

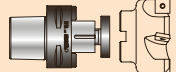

MONOforce
HIGH PRECISION
ULTRA-TIGHT
TOOLHOLDERS **50-51**

DIN 69871



MAS BT



PSC



HSK-A



5 µm

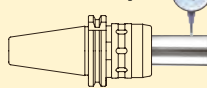

BHT CROSS BARS

39-43

BORING - TURNING

BHT 250 BHT 500 BHT 750
Ø 9.84-19.69 Ø 19.69 - 29.53 Ø 29.53 - 39.37

On request for Ø over 39.37 mm

ROUGHING



PATENTED

ARBORS HT

DIN - BT - PSC - HSK - CAT - MHD'

FINISHING
2 µm

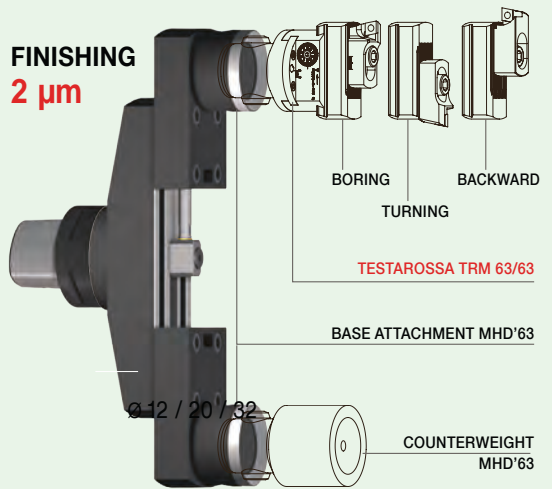

BORING-MILLING MACHINES MEDIUM AND LARGE SIZES

EXTENDED ANGULAR HEADS GEARBOX



HOLE

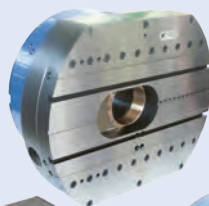

DOUBLE SLIDE



HIGH SPEED (BALANCED)

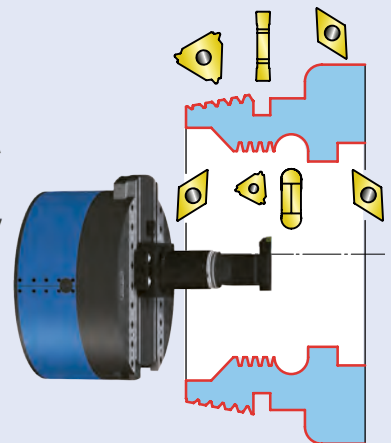
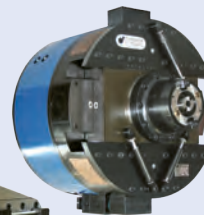

SPECIALS

AR AR 125 AR 160
Ø max 12.60 Ø max 15.75

AUTOMATIC FACING
HEADS

74-75

ARBORS MHD'

MACHINING
CENTERS MILLING
MACHINES

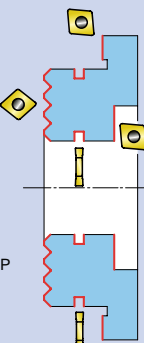
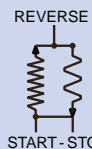

TA-SENSITIV 2

TA-S2.120 TA-S2.170
Ø max 9.84 Ø max 15.75

FACING AND
BORING HEADS

76-77

ARBORS MHD'

MILLING-BORING MACHINE
CONVENTIONAL MACHINES

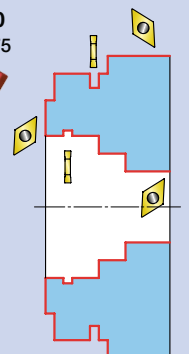
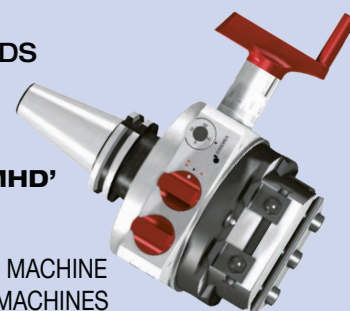

High-precision modular toolholders that allows to perform boring, milling and drilling operations with extreme flexibility and rigidity.

The MHD' coupling is the heart of the tool system Modulhard'andrea. Available in 8 sizes, it guarantees the interchangeability of all the elements of the system, which includes arbors, extensions, reductions and toolholder adapters.



MHD' COUPLING

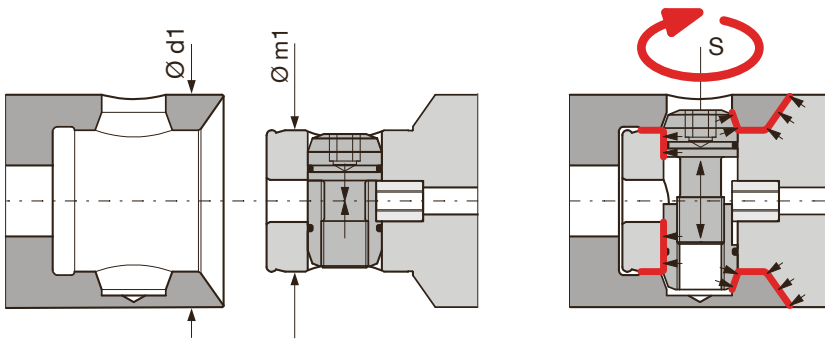

MHD'	Ø d1	Ø m1	⬡ S	lbf-in
16	16	10	2,5	18 - 22
20	20	13	3	35 - 40
25	25	16	3	58 - 66
32	32	20	4	62 - 71
40	40	25	5	142 - 159
50	50	32	6	266 - 310
63	63	42	8	620 - 708
80	80	42	8	620 - 708

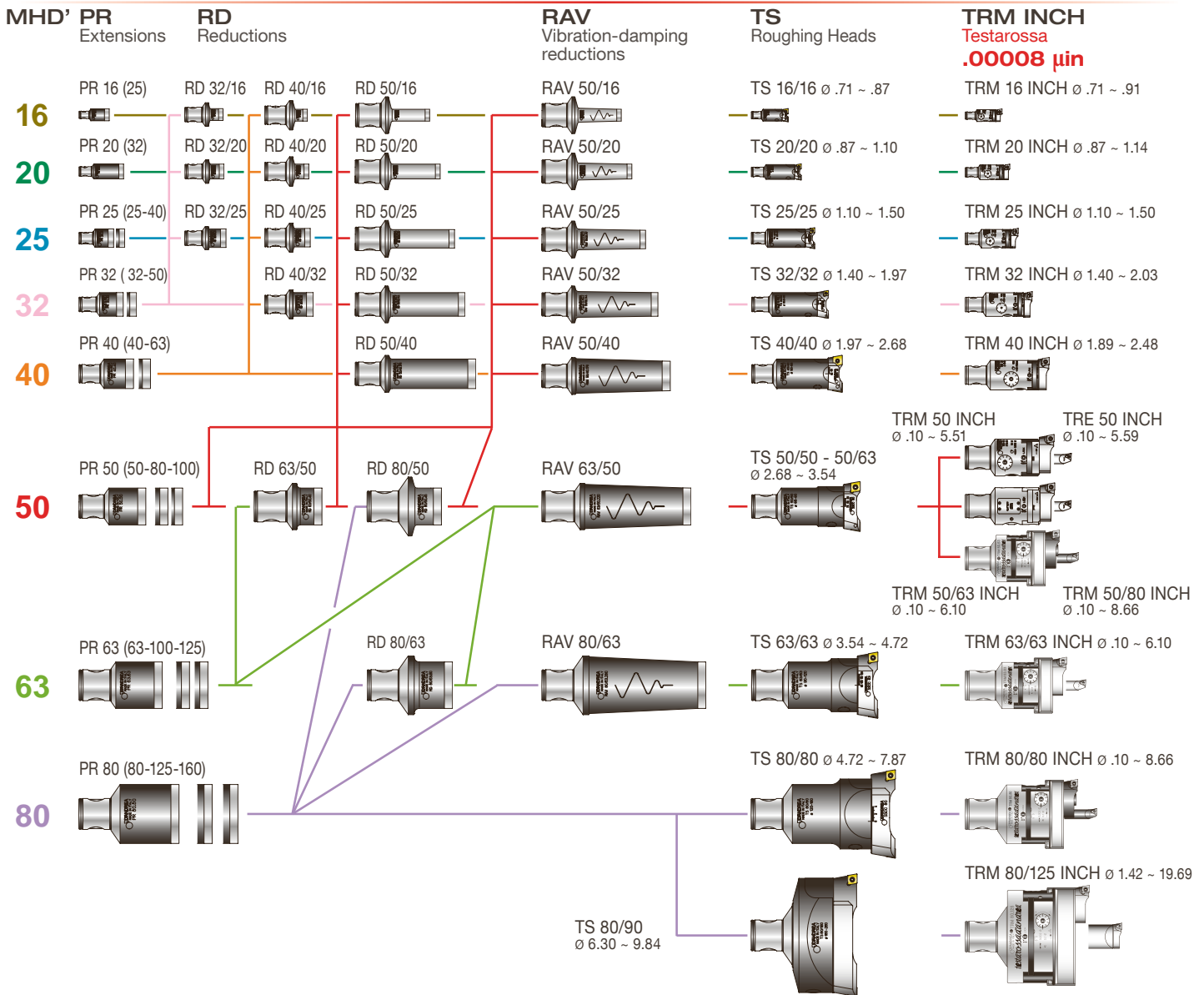
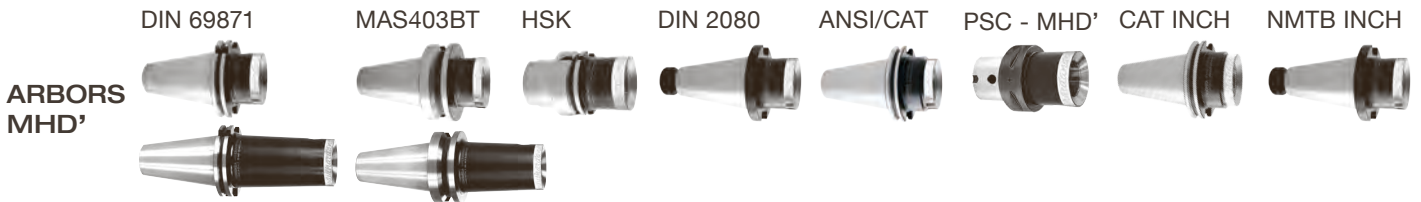

CHUCKING TOOLS



DIN 69871 AD

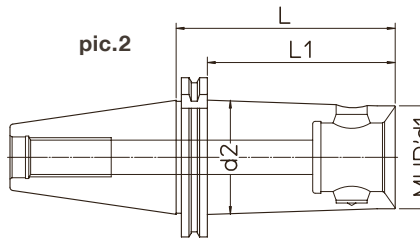
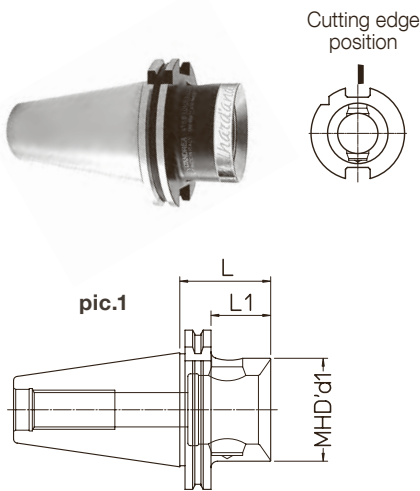

DIN	REF.	CODE	MHD' d1	d2	L	L1	lb	pic.
30	DIN69871-AD30 MHD'50.60	416500103020	50	2.36		1.32	1	
40	DIN69871-AD40 MHD'16.40	416160414020	16	1.57	.83	1.54	1	
40	DIN69871-AD40 MHD'16.63	416160614020	16	.73	2.48	1.73	1.76	2
40	DIN69871-AD40 MHD'16.100	416161014020	16	.85	3.94	3.19	1.98	2
40	DIN69871-AD40 MHD'20.50	416200514020	20	1.97	1.22	1.76	1	
40	DIN69871-AD40 MHD'20.80	416200814020	20	1.00	3.15	2.40	1.98	2
40	DIN69871-AD40 MHD'20.125	416201214020	20	1.02	4.92	4.17	2.20	2
40	DIN69871-AD40 MHD'25.50	416250514020	25	1.97	1.22	1.98	1	
40	DIN69871-AD40 MHD'25.80	416250814020	25	1.10	3.15	2.40	2.20	2
40	DIN69871-AD40 MHD'25.125	416251214020	25	1.22	4.92	4.17	2.43	2
40	DIN69871-AD40 MHD'32.50	416320514020	32	1.97	1.22	2.20	1	
40	DIN69871-AD40 MHD'32.80	416320814020	32	1.32	3.15	2.40	2.43	2
40	DIN69871-AD40 MHD'32.125	416321214020	32	1.36	4.92	4.17	2.65	2
40	DIN69871-AD40 MHD'40.45	416400104020	40	1.77	1.02	1.10	1	
40	DIN69871-AD40 MHD'40.120	416401214020	40	1.54	4.72	3.98	3.09	2
40	DIN69871-AD40 MHD'50.48	416500104020	50	1.89	1.14	1.98	1	
40	DIN69871-AD40 MHD'50.120	416501214020	50	4.72	3.98	3.75	1	
40	DIN69871-AD40 MHD'63.80	416630104020	63	3.15		3.31	1	
50	DIN69871-AD50 MHD'50.48	416500105020	50	1.89	1.14	5.51	1	
50	DIN69871-AD50 MHD'50.120	416501215020	50	2.36	4.72	3.98	7.72	2
50	DIN69871-AD50 MHD'63.56	416630105020	63	2.20	1.46	6.17	1	
50	DIN69871-AD50 MHD'63.150	416631515020	63	2.76	5.91	5.16	11.02	2
50	DIN69871-AD50 MHD'80.62	416800105020	80	2.44	1.69	7.50	1	
50	DIN69871-AD50 MHD'80.180	416801815020	80	7.09	6.34	16.76	1	

B-shape arbors - on request

DIN 69871 FC AD FACE CONTACT

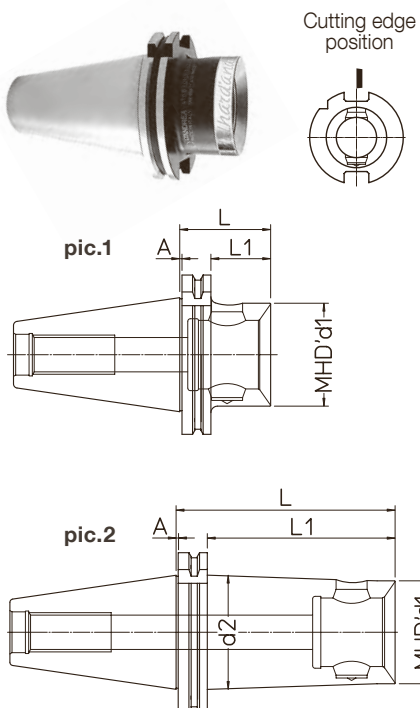

DIN	REF.	CODE	MHD' d1	d2	A	L	L1	lb	pic.
40	DIN69871-AD40 FC MHD'50.48	416500104020F	50	.04	1.89	1.14	1.98	1	
40	DIN69871-AD40 FC MHD'50.120	416501214020F	50	.04	4.72	3.98	3.75	1	
40	DIN69871-AD40 FC MHD'63.80	416630104020F	63	.04	3.15		3.31	1	
50	DIN69871-AD50 FC MHD'50.48	416500105020F	50	.06	1.89	1.14	5.51	1	
50	DIN69871-AD50 FC MHD'50.120	416501215020F	50	2.32	.06	4.72	3.98	7.72	2
50	DIN69871-AD50 FC MHD'50.200	416502015020F	50	68	.06	7.87	7.13	13.45	2
50	DIN69871-AD50 FC MHD'63.56	416630105020F	63	.06	2.20	1.46	6.17	1	
50	DIN69871-AD50 FC MHD'63.150	416631515020F	63	2.97	.06	5.91	5.16	11.46	2
50	DIN69871-AD50 FC MHD'63.250	416632515020F	63	3.15	.06	9.84	9.09	15.65	2
50	DIN69871-AD50 FC MHD'80.62	416800105020F	80	.06	2.44	1.69	7.50	1	
50	DIN69871-AD50 FC MHD'80.180	416801815020F	80	.06	7.09	6.34	15.21	1	
50	DIN69871-AD50 FC MHD'80.300	416803015020F	80	.06	11.81	11.06	20.28	1	

B-shape arbors - on request

Manufactured according to DIN 69871 and MAS 403 BT standards,
made in case-hardened, tempered and ground steel. BALANCING UP TO 8000 RPM.

MAS 403 BT AD

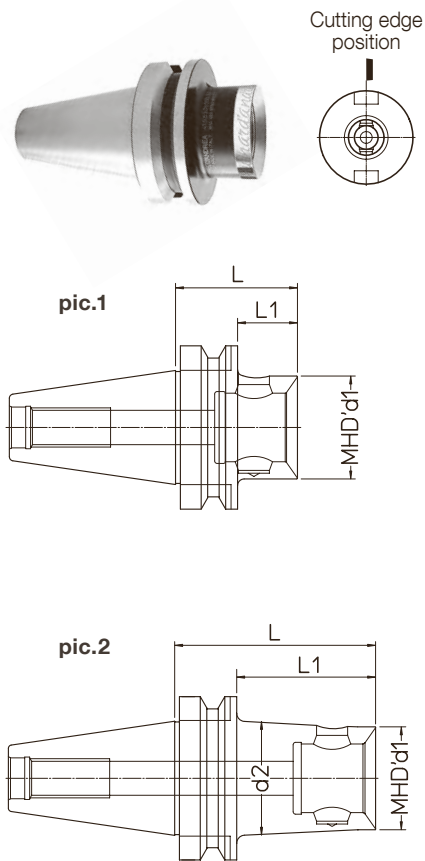

BT	REF.	CODE	MHD' d1	d2	L	L1	lb	pic.
30	MAS403 BT30-AD MHD'50.60	416500103030	50	2.36		1.54	1	
40	MAS403 BT40-AD MHD'16.45	416160414030	16	1.77	.71	1.76	1	
40	MAS403 BT40-AD MHD'16.63	416160614030	16	.67	2.48	1.42	1.98	2
40	MAS403 BT40-AD MHD'16.100	416161014030	16	.77	3.94	2.87	2.20	2
40	MAS403 BT40-AD MHD'20.50	416200514030	20	1.97	.91	1.98	1	
40	MAS403 BT40-AD MHD'20.80	416200814030	20	.87	3.15	2.09	2.20	2
40	MAS403 BT40-AD MHD'20.125	416201214030	20	.98	4.92	3.86	2.43	2
40	MAS403 BT40-AD MHD'25.50	416250514030	25	1.97	.91	2.20	1	
40	MAS403 BT40-AD MHD'25.80	416250814030	25	1.04	3.15	2.09	2.43	2
40	MAS403 BT40-AD MHD'25.125	416251214030	25	1.16	4.92	3.86	2.65	2
40	MAS403 BT40-AD MHD'32.50	416320514030	32		.91	2.43	1	
40	MAS403 BT40-AD MHD'32.80	416320814030	32	1.30	3.15	2.09	2.65	2
40	MAS403 BT40-AD MHD'32.125	416321214030	32	1.42	4.92	3.86	3.09	2
40	MAS403 BT40 AD MHD'40.45	416400104030	40	1.77	.71	1.32	1	
40	MAS403 BT40-AD MHD'40.120	416401214030	40	1.75	4.72	3.66	1.98	2
40	MAS403 BT40-AD MHD'50.48	416500104030	50	1.89	.83	1.98	1	
40	MAS403 BT40-AD MHD'50.120	416501214030	50	4.72	3.66	4.19	2	
40	MAS403 BT40-AD MHD'63.66	416630104030	63	2.60		2.65	1	
50	MAS403 BT50-AD MHD'50.66	416500105030	50	2.60	1.10	7.28	1	
50	MAS403 BT50-AD MHD'50.120	416501215030	50	2.36	4.72	3.23	9.26	2
50	MAS403 BT50-AD MHD'63.75	416630105030	63	2.95	1.46	8.16	1	
50	MAS403 BT50-AD MHD'63.150	416631515030	63	2.76	5.91	4.41	12.79	2
50	MAS403 BT50-AD MHD'80.75	416800105030	80	2.95	1.46	8.82	1	
50	MAS403 BT50-AD MHD'80.180	416801815030	80	7.09	5.59	16.53	2	

B-shape arbors - on request

MAS 403 BT FC AD FACE CONTACT

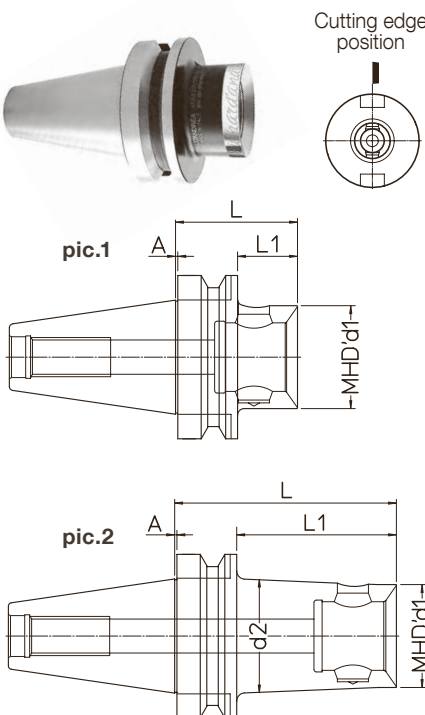

BT	REF.	CODE	MHD' d1	d2	A	L	L1	lb	pic.
40	MAS403 BT40-AD FC MHD'50.48	416500104030F	50	.04	1.89	.83	1.98	1	
40	MAS403 BT40-AD FC MHD'50.120	416501214030F	50	.04	4.72	3.66	4.19	1	
40	MAS403 BT40-AD FC MHD'63.66	416630104030F	63	.04	2.60		2.65	1	
50	MAS403 BT50-AD FC MHD'50.66	416500105030F	50	.06	2.60	1.10	7.05	1	
50	MAS403 BT50-AD FC MHD'50.120	416501215030F	50	2.26	.06	4.72	3.23	9.26	2
50	MAS403 BT50-AD FC MHD'50.200	416502015030F	50	2.60	.06	7.87	6.38	9.92	2
50	MAS403 BT50-AD FC MHD'63.75	416630105030F	63	.06	2.95	1.46	8.16	1	
50	MAS403 BT50-AD FC MHD'63.150	416631515030F	63	2.89	.06	5.91	4.41	12.79	2
50	MAS403 BT50-AD FC MHD'63.250	416632515030F	63	3.31	.06	9.84	8.35	13.45	2
50	MAS403 BT50-AD FC MHD'80.75	416800105030F	80	.06	2.95	1.46	8.82	1	
50	MAS403 BT50-AD FC MHD'80.180	416801815030F	80	.06	7.09	5.59	16.53	1	
50	MAS403 BT50-AD FC MHD'80.300	416803015030F	80	.06	11.81	10.31	20.28	1	

B-shape arbors - on request

DIN 69893 HSK-A

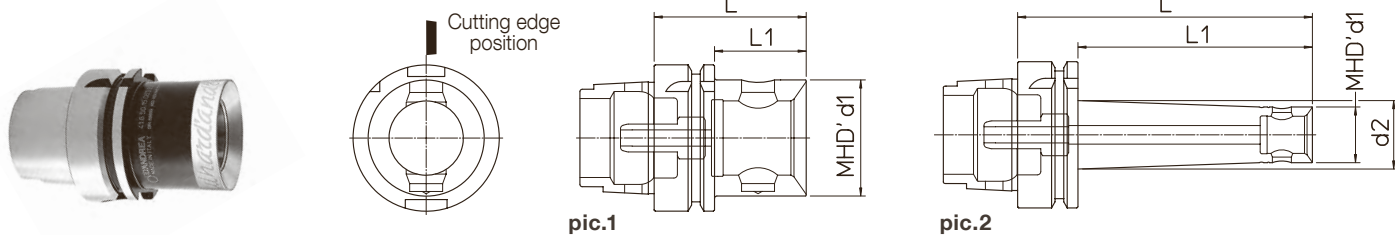

HSK-A	REF.	CODE	MHD' d1	d2	L	L1	lb	pic.	Supplied with coolant tube	
50	HSK-A50 MHD'50.66	416501505020	50		2.60		1.32	1		
63	HSK-A63 MHD'16.100	416161056320	16	.77	3.94	2.91	1.76	2		
63	HSK-A63 MHD'20.125	416201256320	20	.98	4.92	3.90	1.98	2		
63	HSK-A63 MHD'25.125	416251256320	25	1.16	4.92	3.90	2.20	2		
63	HSK-A63 MHD'32.90	416320956320	32	1.32	3.54	2.52	2.20	2		
63	HSK-A63 MHD'32.125	416321256320	32	1.42	4.92	3.90	2.65	2		
63	HSK-A63 MHD'40.60	416401506320	40		2.36	1.34	1.54	1		
63	HSK-A63 MHD'40.120	416401506328	40	1.81	4.72	3.70	3.09	2		
63	HSK-A63 MHD'50.66	416501506320	50		2.60	1.57	4.37	1		
63	HSK-A63 MHD'50.120	416501506328	50		4.72	3.70	3.75	1		
63	HSK-A63 MHD'63.75	416631506320	63		2.95		2.43	1		
80	HSK-A80 MHD'50.70	416501508020	50		2.76	1.73	3.31	1		
80	HSK-A80 MHD'63.80	416631508020	63		3.15	2.13	3.97	1		
100	HSK-A100 MHD'50.72	416501510020	50		2.83	1.69	5.29	1		
100	HSK-A100 MHD'50.120	416501510028	50	2.36	4.72	3.58	7.05	2		
100	HSK-A100 MHD'63.82	416631510020	63		3.23	2.09	5.95	1		
100	HSK-A100 MHD'63.150	416631510028	63	2.76	5.91	4.76	9.92	2		
100	HSK-A100 MHD'80.88	416801510020	80		3.46	2.32	6.61	1		
100	HSK-A100 MHD'80.180	416801510028	80		7.09	5.94	14.33	1		

DIN 2080-A 'OTT'

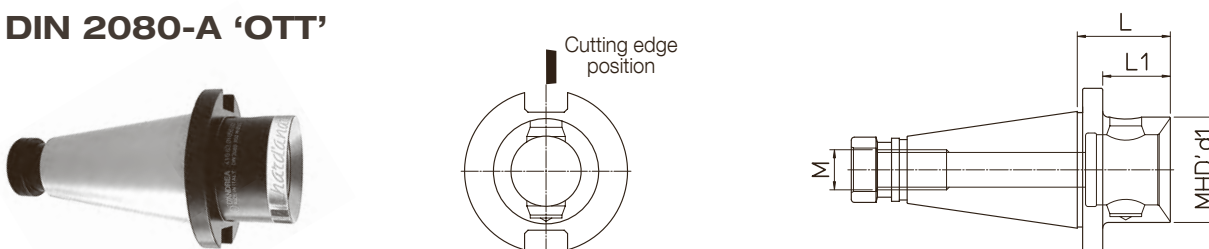

DIN	REF.	CODE	MHD' d1	L	L1	M	lb		
30	DIN2080-A30 MHD'50.58	416500103000	50	2.28		M12	1.32		
40	DIN2080-A40 MHD'50.48	416500104000	50	1.89	1.44	M16	1.98		
40	DIN2080-A40 MHD'63.60	416630104000	63	2.36		M16	2.65		
50	DIN2080-A50 MHD'50.48	416500105000	50	1.89	1.30	M24	5.73		
50	DIN2080-A50 MHD'63.56	416630105000	63	2.20	1.61	M24	5.95		
50	DIN2080-A50 MHD'80.60	416800105000	80	2.36	1.77	M24	7.05		

ANSI/CAT AD

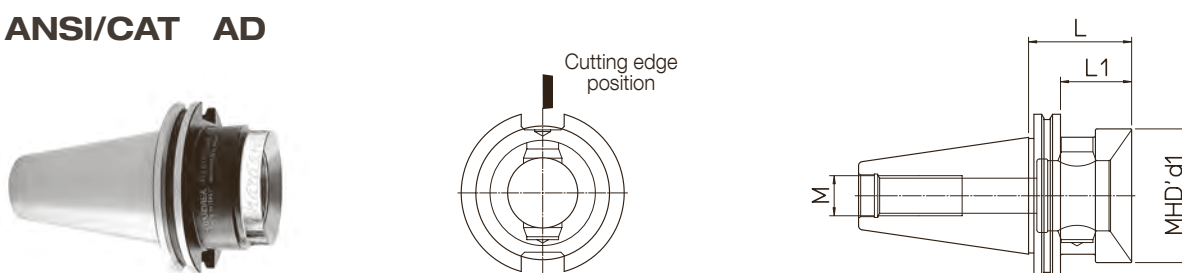

ANSI/CAT	REF.	CODE	MHD' d1	L	L1	M	lb		
40	ANSI/CAT40 MHD'50.66	416500104040	50	2.60	1.85	M16	2.43		
40	ANSI/CAT40 MHD'63.100	416630104040	63	3.94		M16	4.19		
50	ANSI/CAT50 MHD'50.48	416500105040	50	1.89	1.14	M24	5.29		
50	ANSI/CAT50 MHD'63.56	416630105040	63	2.20	1.46	M24	6.39		
50	ANSI/CAT50 MHD'80.62	416800105040	80	2.44	1.69	M24	7.05		

CAT INCH AD

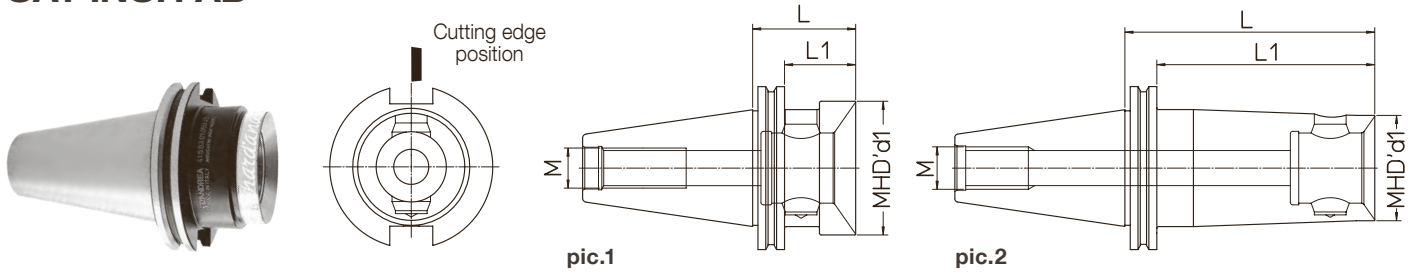

CAT	REF.	CODE	MHD' d1	L	L1	M	lb	pic.
40	CAT40 UNC AD MHD'50.66	416500104045	50	2.59	1.85	UNC 5/8 - 11	2.43	1
40	CAT40 UNC AD MHD'50.120	416500104049	50	4.72	3.98	UNC 5/8 - 11	3.75	2
40	CAT40 UNC AD MHD'63.100	416630104045	63	3.94		UNC 5/8 - 11	4.19	1
50	CAT50 UNC AD MHD'50.48	416500105045	50	1.89	1.14	UNC 1 - 8	5.29	1
50	CAT50 UNC AD MHD'50.120	416500105049	50	4.72	3.9	UNC 1 - 8	7.72	2
50	CAT50 UNC AD MHD'63.56	416630105045	63	2.20	1.45	UNC 1 - 8	6.39	1
50	CAT50 UNC AD MHD'63.150	416630105049	63	5.90	5.16	UNC 1 - 8	11.02	2
50	CAT50 UNC AD MHD'80.62	416800105045	80	2.44	1.69	UNC 1 - 8	7.05	1
50	CAT50 UNC AD MHD'80.180	416800105049	80	7.09	6.34	UNC 1 - 8	15.21	2

CAT INCH FC AD FACE CONTACT

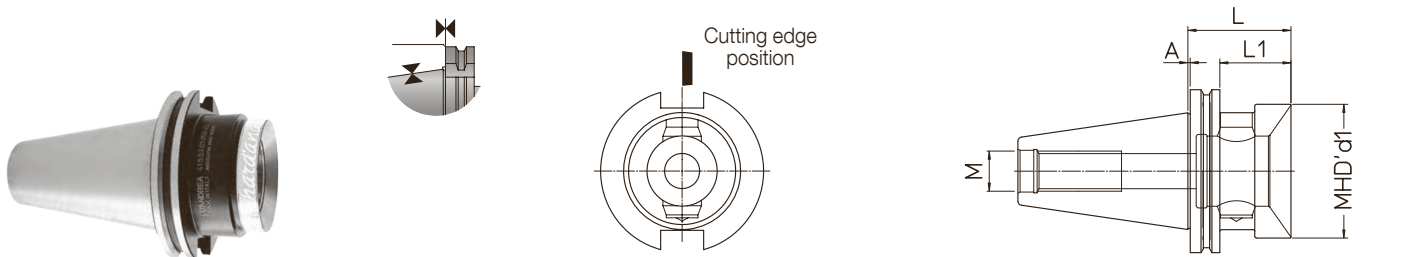

CAT	REF.	CODE	MHD' d1	L	L1	M	lb
40	CAT40 UNC FC AD MHD'50.66	416500104045F	50	2.59	1.85	UNC 5/8 - 11	2.43
50	CAT50 UNC FC AD MHD'50.48	416500105045F	50	1.89	1.14	UNC 1 - 8	5.29
50	CAT50 UNC FC AD MHD'63.56	416630105045F	63	2.20	1.46	UNC 1 - 8	6.39
50	CAT50 UNC FC AD MHD'80.62	416800105045F	80	2.44	1.69	UNC 1 - 8	7.09

NMTB INCH

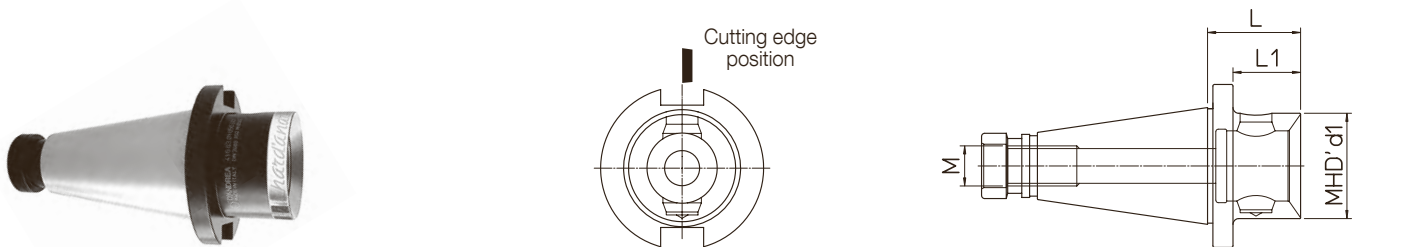

CAT	REF.	CODE	MHD' d1	L	L1	M	lb
40	NMTB40 UNC5/8-11 MHD'50.48	416500104005	50	1.88	1.43	UNC 5/8 - 11	1.9
50	NMTB50 UNC1-8 MHD'50.48	416500105005	50	1.88	1.30	UNC 1 - 8	5.73
50	NMTB50 UNC1-8 MHD'63.56	416630105005	63	2.20	1.61	UNC 1 - 8	5.95
50	NMTB50 UNC1-8 MHD'80.60	416800105005	80	2.36	1.77	UNC 1 - 8	7.05

PR EXTENSIONS

For each MHD size there are extensions of different lengths that can be used to achieve the desired machining depths.

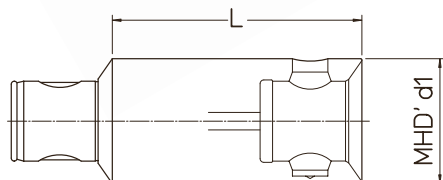

REF.	CODE	MHD' d1	L	lb
PR 16.25	656901600250	16	.98	0.09
PR 20.32	656902000320	20	1.26	0.15
PR 25.25	656902500250	25	.98	0.20
PR 25.40	656902500400	25	1.57	0.33
PR 32.32	656903200320	32	1.26	0.44
PR 32.50	656903200500	32	1.97	0.66
PR 40.40	656904000400	40	1.57	0.88
PR 40.63	656904000630	40	2.48	1.32
PR 50.50	656905000500	50	1.97	1.54
PR 50.80	656905000800	50	3.15	2.43
PR 50.100	656905001000	50	3.94	3.31
PR 63.63	656906300630	63	2.48	3.09
PR 63.100	656906301000	63	3.94	4.85
PR 63.125	656906301250	63	4.92	6.39
PR 80.80	656908000800	80	3.15	6.61
PR 80.125	656908001250	80	4.92	10.14
PR 80.160	656908001600	80	6.30	13.45

RD REDUCTIONS

The reductions allow the use of MHD components of a smaller size thereby optimising the composition of the tool according to the overall dimensions.

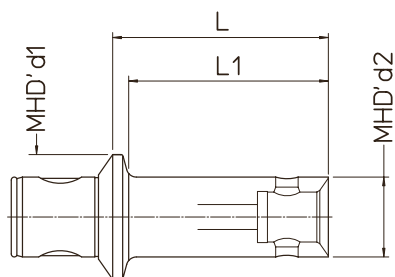

REF.	CODE	MHD' d1	MHD' d2	L	L1	lb
RD 20/16.20	657002000160	20	16	.79	.63	0.11
RD 25/16.20	657002500160	25	16	.79	.59	0.15
RD 25/20.25	657002500200	25	20	.98	.59	0.18
RD 32/16.24	657003200160	32	16	.94	.71	0.10
RD 32/20.25	657003200200	32	20	.98	.59	0.22
RD 32/25.28	657003200250	32	25	1.10	.91	0.31
RD 40/16.24	657004000160	40	16	.94	.67	0.40
RD 40/20.26	657004000200	40	20	1.02	.59	0.44
RD 40/25.28	657004000250	40	25	1.10	.87	0.55
RD 40/32.32	657004000320	40	32	1.26	1.06	0.66
RD 50/16.24	657005000160	50	16	.94	.59	0.75
RD 50/16.40	657005000162	50	16	1.57	1.26	0.44
RD 50/16.74	657005000163	50	16	2.91	2.56	0.55
RD 50/20.26	657005000200	50	20	1.02	.71	0.37
RD 50/20.70	657005000202	50	20	2.76	2.44	0.66
RD 50/20.93	657005000203	50	20	2.76	3.35	0.77
RD 50/25.28	657005000250	50	25	1.10	.83	0.88
RD 50/25.87	657005000252	50	25	3.43	3.15	1.32
RD 50/25.117	657005000253	50	25	4.61	110	1.43
RD 50/32.32	657005000320	50	32	1.26	.98	0.99
RD 50/32.87	657005000322	50	32	3.43	3.15	1.65
RD 50/32.144	657005000323	50	32	5.67	5.39	2.20
RD 50/40.36	657005000400	50	40	1.42	1.18	1.10
RD 50/40.87	657005000402	50	40	3.43	3.15	1.98
RD 50/40.176	657005000403	50	40	6.93	.670	3.97
RD 63/50.40	657006300500	63	50	1.57	1.34	1.98
RD 80/50.45	657008000500	80	50	1.77	1.42	2.65
RD 80/63.60	657008000630	80	63	2.36	2.05	3.75

RAV VIBRATION-DAMPING

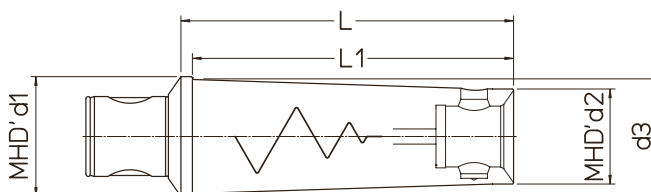

Anti-vibration reductions for deep or heavy-duty machining.

REF.	CODE	MHD' d1	MHD' d2	d3	L	L1	lb
RAV 50/16.74	657005000165	50	16	.69	2.91	2.56	0.88
RAV 50/20.93	657005000205	50	20	.85	3.66	3.35	1.10
RAV 50/25.117	657005000255	50	25	1.06	4.61	4.33	1.76
RAV 50/32.144	657005000325	50	32	1.38	5.67	5.43	3.09
RAV 50/40.176	657005000405	50	40	1.85	6.93	6.69	5.51
RAV 63/50.220	657006300505	63	50	2.36	8.66	8.43	12.35
RAV 80/63.280	657008000635	80	63	3.03	11.02	10.71	23.37

BORING



TS 16 ~ 80 \varnothing .71 ~ 9.84

Simple and extremely rigid roughing heads, thanks to the serrated surfaces between the head body and the bit holders. The constant distance between the bit holder clamping screw and the cutting edge guarantees the stability of the system.

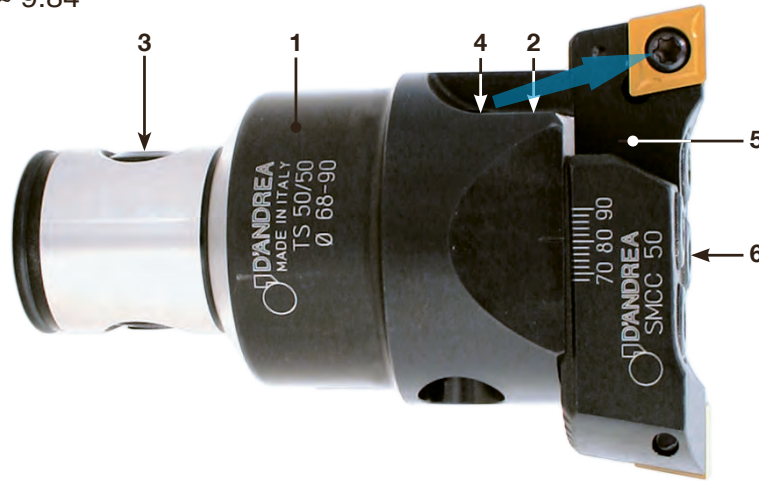

- 1. Body
- 2. Setting screws
- 3. Expanding pin
- 4. Coolant outlets
Max 580 PSI
- 5. Bit holders
- 6. Tools clamp screws

TS 16/16 \varnothing .71 ~ .87

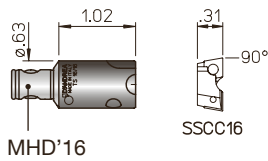

TS 40/40 \varnothing 1.97 ~ 2.68

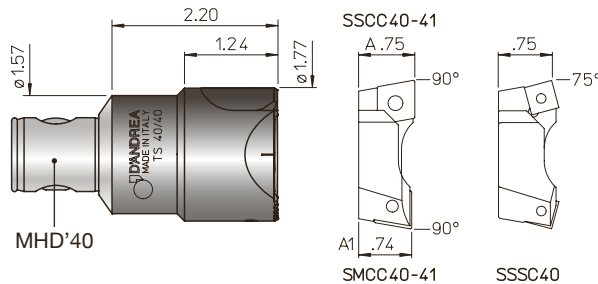

TS 20/20 \varnothing .87 ~ 1.10

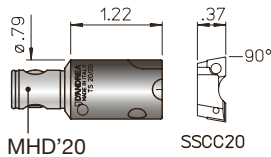

TS 50/50 \varnothing 2.68 ~ 3.54

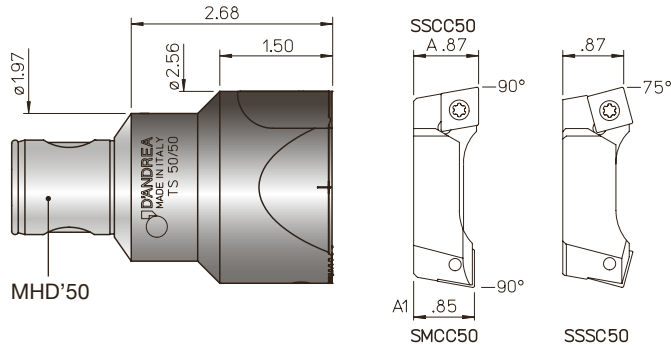

TS 25/25 \varnothing 1.10 ~ 1.50

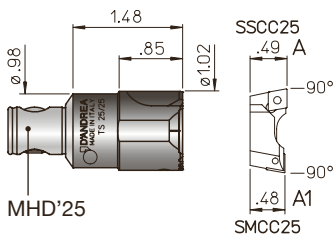

TS 50/63 - TS 63/63 \varnothing 3.54 ~ 4.72

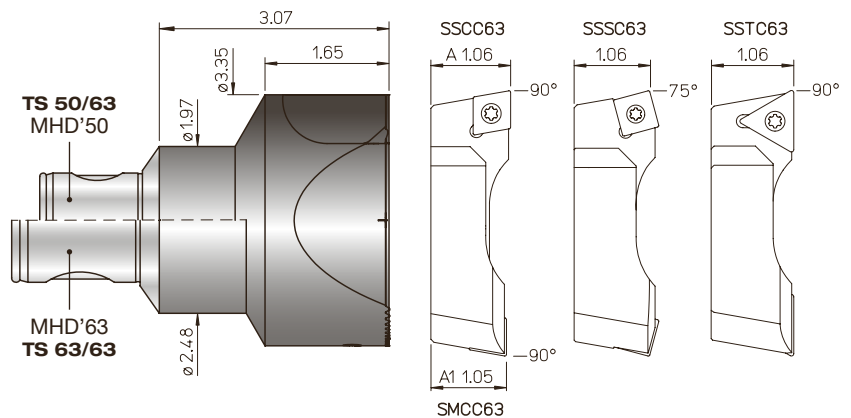

TS 32/32 \varnothing 1.40 ~ 1.97

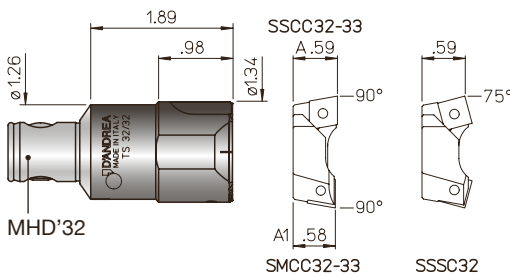

REF.	CODE	lb
TS 16/16	455501600340	0.05
TS 20/20	455502000400	0.09
TS 25/25	455502500510	0.2
TS 32/32	455503200638	0.35
TS 40/40	455504040070	0.7

REF.	CODE	lb
TS 50/50	455505050090	1.5
TS 50/63	455505063100	2
TS 63/63	455506363100	3
TS 80/80	455508080110	5.3
TS 80/90	455508090090	6.3

TS 80/80 Ø 4.72 ~ 7.87

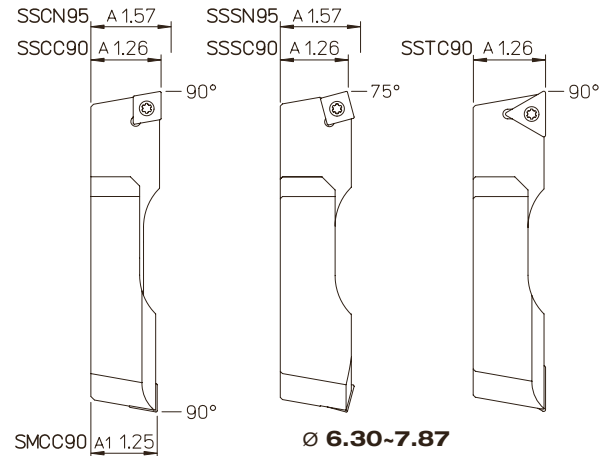
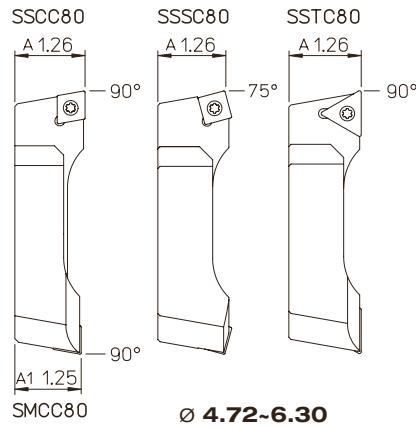
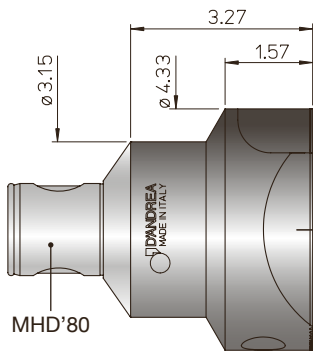

TS 80/90 Ø 6.30 ~ 9.84

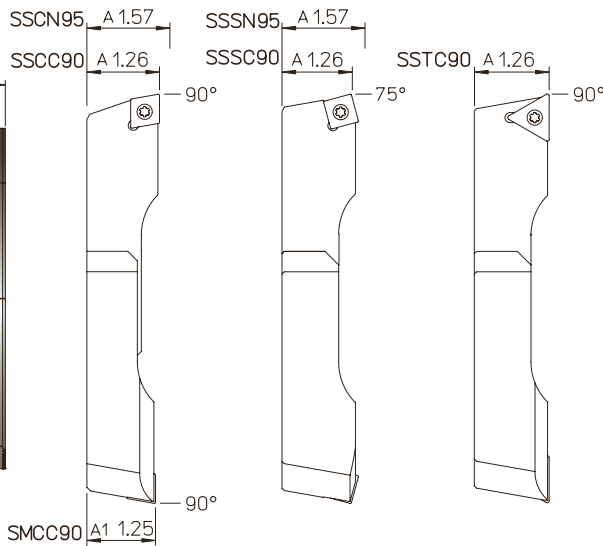
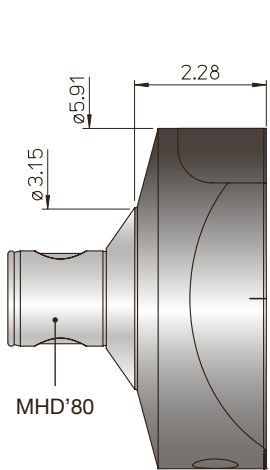

Ø 6.30-9.84

USE TS for ROUGHING end SEMI-FINISHING operations

Roughing and semi-finishing operations. Cutting edges might be adjusted on a pre-setting bench and TS heads can be used in three different configurations, with a single cutting edge (pic. 3) or misaligned ones (pic.2) half the feed.

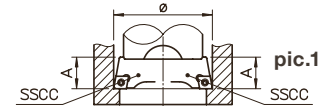

pic.1 with two SSCC bit holders aligned and on the same diameter for roughing operations with high feedrate.

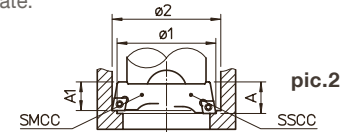

pic.2 with one SSCC bit holder and one SMCC bit holder staggered and on a different diameter for roughing operations with high depth of cut.



pic.3 with a single bit holder for roughing or semi-finishing operations.

REF.	CODE		TS	TORX	T	lb
SSCC 16	470500516201	CCMT 0602..	25	08	0.01	
SSCC 20	470500520201	CCMT 0602..	25	08	0.01	
SSCC 25	470500525201	CCMT 0602..	25	08	0.22	
SSCC 32	470500532201	CCMT 0602..	25	08	0.04	
SSCC 33	470500532204	CCMT 09T3..	4	15	0.13	
SSCC 40	470500540201	CCMT 09T3..	4	15	0.13	
SSCC 41	470500540204	CCMT 1204..	5	25	0.13	
SSCC 50	470500550204	CCMT 1204..	5	25	0.22	
SSCC 63	470500563201	CCMT 1204..	5	25	0.44	
SSCC 80	470500580201	CCMT 1204..	5	25	1.10	
SSCC 90	470500590201	CCMT 1204..	5	25	1.54	
SSCN 95	470500595201	CNM. 1906..			1.98	
SSTC 63	470500563206	TCMT 2204..	5	25	0.44	
SSTC 80	470500580206	TCMT 2204..	5	25	1.10	
SSTC 90	470500590206	TCMT 2204..	5	25	1.54	

REF.	CODE		TS	TORX	T	lb
SMCC 25	470500525203	CCMT 0602..	25	08	0.02	
SMCC 32	470500532203	CCMT 0602..	25	08	0.04	
SMCC 33	470500532205	CCMT 09T3..	4	15	0.06	
SMCC 40	470500540203	CCMT 09T3..	4	15	0.13	
SMCC 41	470500540205	CCMT 1204..	5	25	0.13	
SMCC 50	470500550205	CCMT 1204..	5	25	0.22	
SMCC 63	470500563203	CCMT 1204..	5	25	0.44	
SMCC 80	470500580203	CCMT 1204..	5	25	1.10	
SMCC 90	470500590203	CCMT 1204..	5	25	1.54	
SSSC 32	470500532202	SCMT 09T3..	4	15	0.04	
SSSC 40	470500540202	SCMT 09T3..	4	15	0.06	
SSSC 50	470500550202	SCMT 1204..	5	25	0.13	
SSSC 63	470500563202	SCMT 1204..	5	25	0.44	
SSSC 80	470500580202	SCMT 1204..	5	25	1.10	
SSSC 90	470500590202	SCMT 1204..	5	25	1.54	
SSSN 95	470500595202	SNM. 1906..			p.55 1.98	

• For back-facing machining see p.23

TRM 16 ~ 125 INCH Ø .10 ~ 19.69 TESTAROSSA INCH

TRM 16 INCH	RPM 12.000
TRM 20 INCH	RPM 12.000
TRM 25 INCH	RPM 10.000
TRM 32 INCH	RPM 10.000
TRM 40 INCH	RPM 8.000
TRM 50 INCH	RPM 8.000
TRM 63 INCH	RPM 6.000
TRM 80 INCH	RPM 5.000
TRM 125 INCH	RPM 4.000

TRM heads allow high precision machining and excellent surface finish in **IT6** grade of tolerance. The adjustment sensitivity of **.00004 µin** on the radius is easily readable on the vernier scale and can also be performed in the machine.

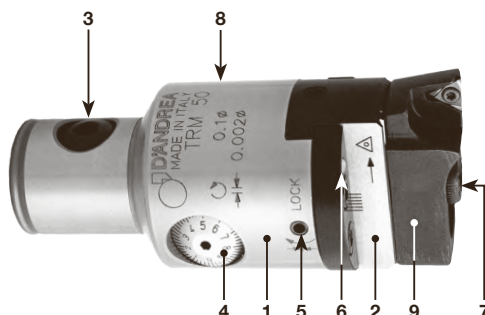

.00008 µin



1. Body
2. Slide toolholder
3. Expanding radial pin
4. Micrometric vernier scale
5. Slide clamp screw
6. Coolant outlet
7. Tools clamp screws
8. Oiler
9. Bit holder
10. Tool holder

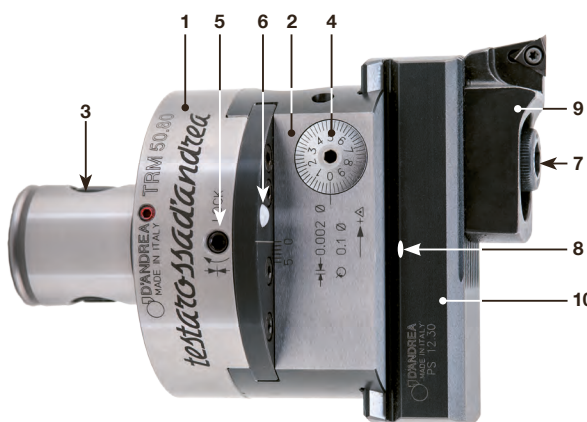

TRE 50 IP69K Ø .10 ~ 5.59 TESTAROSSA DIGITAL

TRE 50 69K INCH RPM 20.000

TRE heads allow high precision machining and excellent surface finish in **IT6** grade of tolerance. The adjustment of **.00004 µin** on the radius is fast, accurate and easily readable on the integrated display. The **TRE 50** is resistant to infiltrations according to the **IP69K** grade.

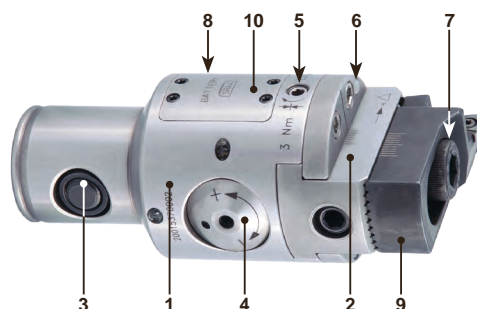

.00008 µin



1. Body
2. Slide toolholder
3. Expanding radial pin
4. Set screw
5. Slide clamp screw
6. Coolant outlet
7. Tools clamp screws
8. Oiler
9. Bit holder
10. Battery compartment cover
11. Digital display
12. Selection button



TRM 16 \varnothing .71 ~ .91

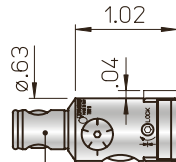

MHD'16

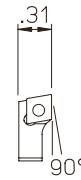

SFCC16

TRM 20 \varnothing .87 ~ 1.14

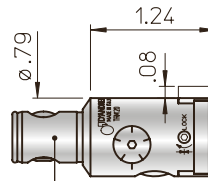

MHD'20

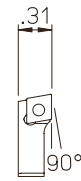

SFCC20

TRM 25 \varnothing 1.10 ~ 1.50

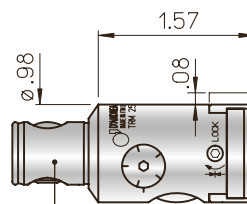

MHD'25

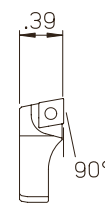

SFCC25

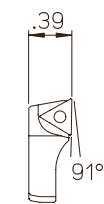

SFTP25

TRM 32 \varnothing 1.40 ~ 2.03

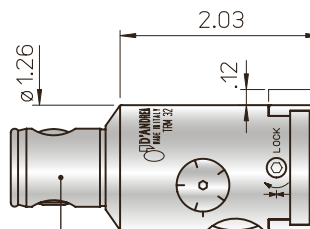

MHD'32

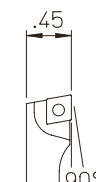

SFCC32

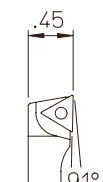

SFTP32

TRM 40 \varnothing 1.89 ~ 2.48

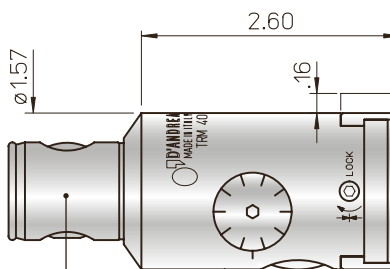

MHD'40

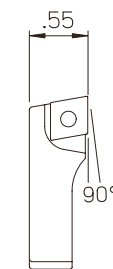

SFCC40



SFTP40

REF.	CODE	lb
TRM 16 INCH	455001660341	0.11
TRM 20 INCH	455002060401	0.22
TRM 25 INCH	455002560500	0.44
TRM 32 INCH	455003260630	0.77
TRM 40 INCH	455004060800	1.54

REF.	CODE		TORX T	lb
SFCC 16	470500516002	CCGT 0602..	TS 25 08	0.01
SFCC 20	470500520002	CCGT 0602..	TS 25 08	0.01
SFCC 25	470500525002	CCGT 0602..	TS 25 08	0.02
SFCC 32	470500532002	CCGT 0602..	TS 25 08	0.04
SFCC 40	470500540002	CCGT 09T3..	TS 4 15	0.09
SFTP 25	470500525001	TPGX 0902..	CS 250T 08	0.02
SFTP 32	470500532001	TPGX 0902..	CS 250T 08	0.04
SFTP 40	470500540001	TPGX 1103..	CS 300890T 08	0.09

• For back-facing machining see p.23

TRM 50 Ø .10 ~ 5.51

TRE 50 IP69K Ø .10 ~ 5.59

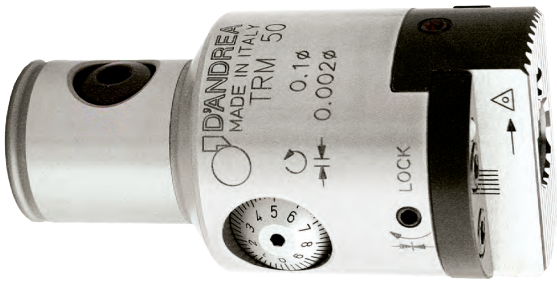

.00008 μin

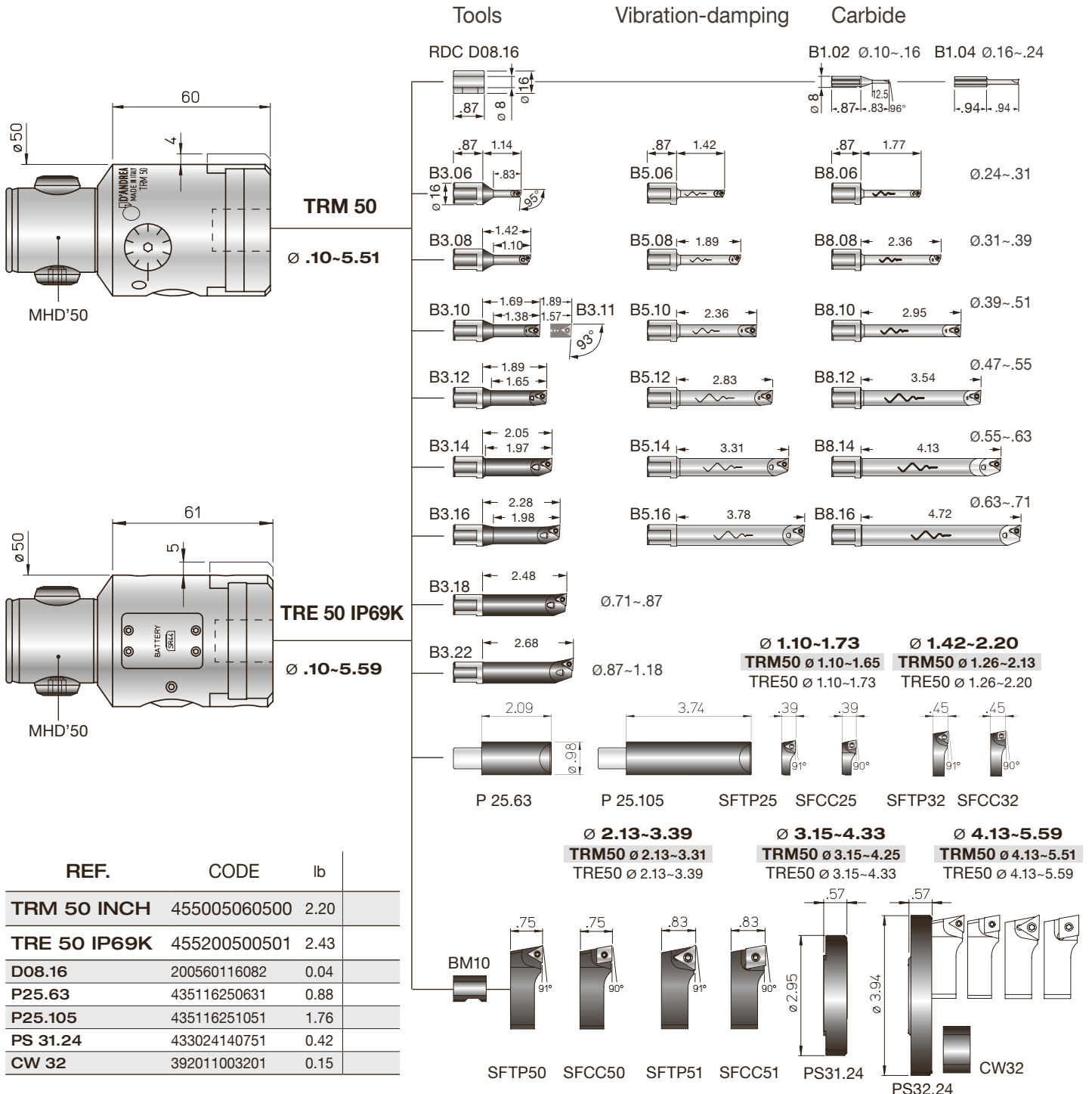

KIT K01 TRM 50 Ø .24 ~ 5.51



- 1 TRM 50**
- 1 B3.06
- 1 B3.08
- 1 B3.11
- 1 B3.16
- 1 B3.22
- 1 SFTP 25
- 1 SFTP 32
- 1 SFTP 50
- 1 P 25.63
- 1 PS 31.24
- 1 PS 32.24
- 1 CW 32
- 5 TPGX 090202L DC100
- 1 TPGX 110302L DC100
- 2 WCGT 020102L DC10

KIT K01 TRE 50 IP69K Ø .24 ~ 5.59



- 1 TRE 50**
- 1 B3.06
- 1 B3.08
- 1 B3.11
- 1 B3.16
- 1 B3.22
- 1 SFTP 25
- 1 SFTP 32
- 1 SFTP 50
- 1 P 25.63
- 1 PS 31.24
- 1 PS 32.24
- 1 CW 32
- 5 TPGX 090202L DC100
- 1 TPGX 110302L DC100
- 2 WCGT 020102L DC10

REF.	CODE	lb		
KIT K01 TRM 50 INCH	655005060502	6.83		

REF.	CODE	lb		
KIT K01 TRE 50 IP69K	655200500504	6.83		

KIT K01 TRM 50 - TRE 50 IP69K

Working Range

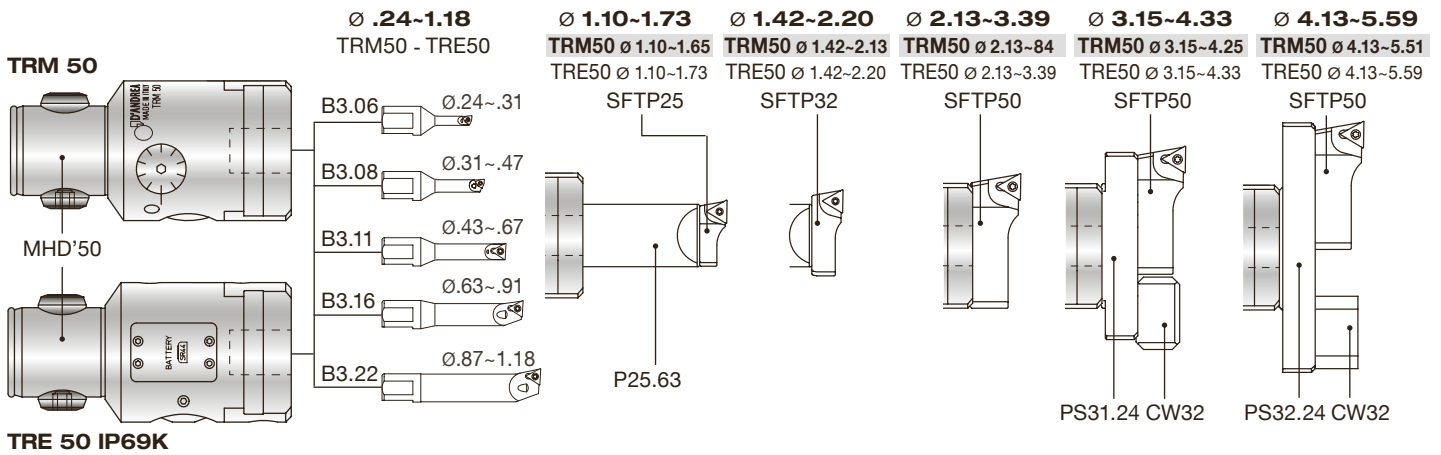

REF.	CODE	TORX T	lb
B1.02	572010502001		0.04
B1.04	572010504001		0.04
B3.06	572010506001	WCGT0201.. TS 21 06	0.08
B3.08	572010508001	WCGT0201.. TS 211 06	0.09
B3.10	572010510001	TPGX0902.. CS 250 T 08	0.11
B3.11	572010511001	TPGX0902.. CS 250 T 08	0.12
B3.12	572010512001	TPGX0902.. CS 250 T 08	0.06
B3.14	572010514001	TPGX0902.. CS 250 T 08	0.15
B3.16	572010516001	TPGX0902.. CS 250 T 08	0.15
B3.18	572010518001	TPGX0902.. CS 250 T 08	0.22
B3.22	572010522001	TPGX0902.. CS 250 T 08	0.22

REF.	CODE	TORX T	lb
B5.06	572010506105	WCGT0201.. TS 21 06	0.17
B5.08	572010508105	WCGT0201.. TS 211 06	0.20
B5.10	572010510105	TPGX0902.. CS 250 T 08	0.22
B5.12	572010512105	TPGX0902.. CS 250 T 08	0.22
B5.14	572010514105	TPGX0902.. CS 250 T 08	0.44
B5.16	572010516105	TPGX0902.. CS 250 T 08	0.3
B8.06	572010506108	WCGT0201.. TS 21 06	0.66
B8.08	572010508108	WCGT0201.. TS 211 06	0.18
B8.10	572010510108	TPGX0902.. CS 250 T 08	0.22
B8.12	572010512108	TPGX0902.. CS 250 T 08	0.44
B8.14	572010514108	TPGX0902.. CS 250 T 08	0.44
B8.16	572010516108	TPGX0902.. CS 250 T 08	0.66

REF.	CODE	TORX T	lb
SFTP25	470500525001	TPGX0902.. CS 250T 08	0.02
SFTP32	470500532001	TPGX0902.. CS 250T 08	0.09
SFTP50	470500550001	TPGX1103.. CS300890T 08	0.18
SFTP51	470500550003	TCMT16T3.. TS 4 15	0.20

REF.	CODE	TORX T	lb
SFCC25	470500525002	CCGT0602.. TS 25 08	0.02
SFCC32	470500532002	CCGT0602.. TS 25 08	0.04
SFCC50	470500550002	CCGT09T3.. TS 4 15	0.18
SFCC51	470500550004	CCMT1204.. TS 5 25	0.20

• For back-facing machining see p.23

TRM 50/63 - TRM 63/63

Ø .10 ~ 6.10



TRM 50/80 - TRM 80/80

Ø .10 ~ 8.66



.00008 μin

Tools	Vibration-damping	Carbide
RDC D08.16	B1.02 Ø.10~.16	B1.04 Ø.16~.24
B3.06	B5.06	B8.06 Ø.24~.31
B3.08	B5.08	B8.08 Ø.31~.39
B3.10	B5.10	B8.10 Ø.39~.51
B3.11	B5.11	B8.11 Ø.47~.55
B3.12	B5.12	B8.12 Ø.55~.63
B3.14	B5.14	B8.14 Ø.63~.71
B3.16	B5.16	B8.16 Ø.71~.87
B3.18	B5.18	B8.18 Ø.87~.118
B3.22	B5.22	B8.22 Ø.118~.187

REF.	CODE	lb
TRM 50/63 INCH	455005060631	2.43
TRM 63/63 INCH	455006360631	3.31
TRM 50/80 INCH	455005060801	4.41
TRM 80/80 INCH	455008060801	5.51
D08.16	200560116082	0.04
P20.30	431030160300	0.44
P02.30	431030250400	0.66
P03.30	431030250700	0.88
P04.30	431030251150	1.54
PS 11.30	433030260750	0.88
PS 12.30	433030260950	1.10
PS 13.30	433030261400	1.54

TRM63	TRM63 - TRM80	TRM80	TRM80
Ø 3.03~3.94	Ø 3.74~6.10	Ø 3.74~5.51	Ø 5.51~8.66

KIT K01 TRM 50/63 - 63/63

Ø .24 ~ 6.10



1 TRM 50/63 - 63/63

- 1 P20.30
- 1 PS11.30
- 1 PS12.30
- 1 P02.30
- 1 P03.30
- 1 B3.06
- 1 B3.08
- 1 B3.11
- 1 B3.16
- 1 B3.22
- 1 SFTP25
- 1 SFTP32
- 1 SFTP50

- 5 TPGX 090202L DC100
- 1 TPGX 110302L DC100
- 2 WCGT 020102L DC 10

REF.	CODE	lb		
KIT K01 TRM50/63 INCH	655005060633	8.60		
KIT K01 TRM63/63 INCH	655006360633	9.26		

KIT K01 TRM 50/80 - 80/80

Ø .24 ~ 8.66



1 TRM 50/80 - 80/80

- 1 P20.30
- 1 PS12.30
- 1 PS13.30
- 1 P02.30
- 1 P03.30
- 1 P04.30
- 1 B3.06
- 1 B3.08
- 1 B3.11
- 1 B3.16
- 1 B3.22
- 1 SFTP25
- 1 SFTP32
- 1 SFTP50

- 5 TPGX 090202L
- 1 TPGX 110302L
- 2 WCGT 020102L

REF.	CODE	lb		
KIT K01 TRM50/80 INCH	655005060802	13.67		
KIT K01 TRM80/80 INCH	655008060802	14.55		

KIT K01 TRM 50/63 - 63/63

Working Range

Ø .24~1.18

Ø 1.18~3.03

Ø 3.03~6.10

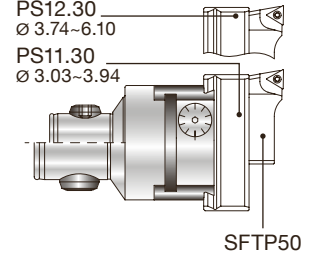
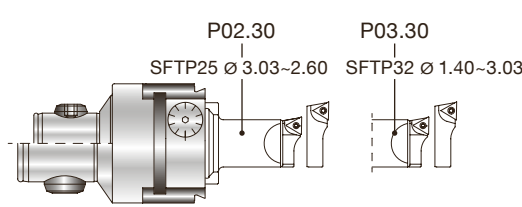
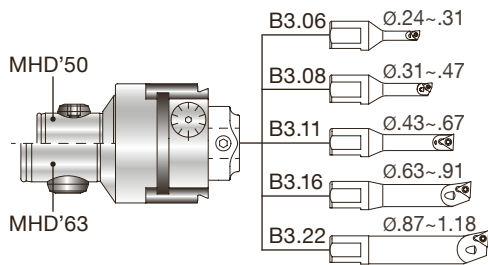

KIT K01 TRM 50/80 - 80/80

Working Range

Ø .24~1.18

Ø 1.18~3.74

Ø 3.74~8.66

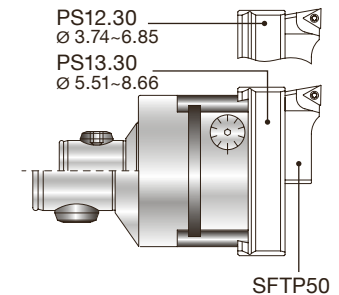
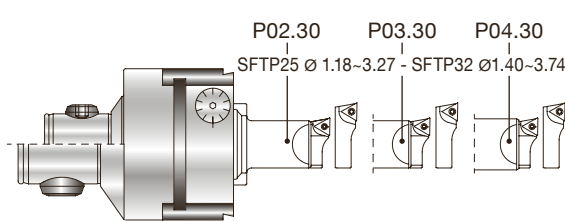
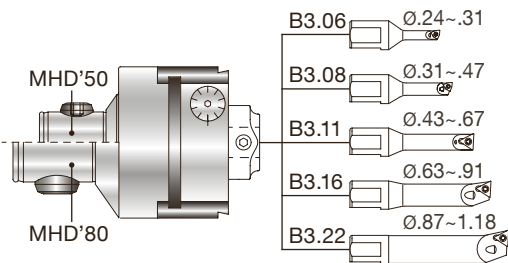

REF.	CODE		TORX T	lb
B1.02	572010502001			0.04
B1.04	572010504001			0.04
B3.06	572010506001	WCGT0201..	TS 21 06	0.08
B3.08	572010508001	WCGT0201..	TS 211 06	0.09
B3.10	572010510001	TPGX0902..	CS 250 T 08	0.11
B3.11	572010511001	TPGX0902..	CS 250 T 08	0.12
B3.12	572010512001	TPGX0902..	CS 250 T 08	0.06
B3.14	572010514001	TPGX0902..	CS 250 T 08	0.15
B3.16	572010516001	TPGX0902..	CS 250 T 08	0.15
B3.18	572010518001	TPGX0902..	CS 250 T 08	0.22
B3.22	572010522001	TPGX0902..	CS 250 T 08	0.22

REF.	CODE		TORX T	lb
B5.06	572010506105	WCGT0201..	TS 21 06	0.17
B5.08	572010508105	WCGT0201..	TS 211 06	0.20
B5.10	572010510105	TPGX0902..	CS 250 T 08	0.22
B5.12	572010512105	TPGX0902..	CS 250 T 08	0.22
B5.14	572010514105	TPGX0902..	CS 250 T 08	0.44
B5.16	572010516105	TPGX0902..	CS 250 T 08	0.3
B8.06	572010506108	WCGT0201..	TS 21 06	0.66
B8.08	572010508108	WCGT0201..	TS 211 06	0.18
B8.10	572010510108	TPGX0902..	CS 250 T 08	0.22
B8.12	572010512108	TPGX0902..	CS 250 T 08	0.44
B8.14	572010514108	TPGX0902..	CS 250 T 08	0.44
B8.16	572010516108	TPGX0902..	CS 250 T 08	0.66

REF.	CODE		TORX T	lb
SFTP25	470500525001	TPGX0902..	CS 250T 08	0.02
SFTP32	470500532001	TPGX0902..	CS 250T 08	0.09
SFTP50	470500550001	TPGX1103..	CS300890T 08	0.18
SFTP51	470500550003	TCMT16T3..	TS 4 15	0.20

REF.	CODE		TORX T	lb
SFCC25	470500525002	CCGT0602..	TS 25 08	0.02
SFCC32	470500532002	CCGT0602..	TS 25 08	0.04
SFCC50	470500550002	CCGT09T3..	TS 4 15	0.18
SFCC51	470500550004	CCMT1204..	TS 5 25	0.20

• For back-facing machining see p.23

TRM 80/125 \varnothing 1.42 ~ 19.69

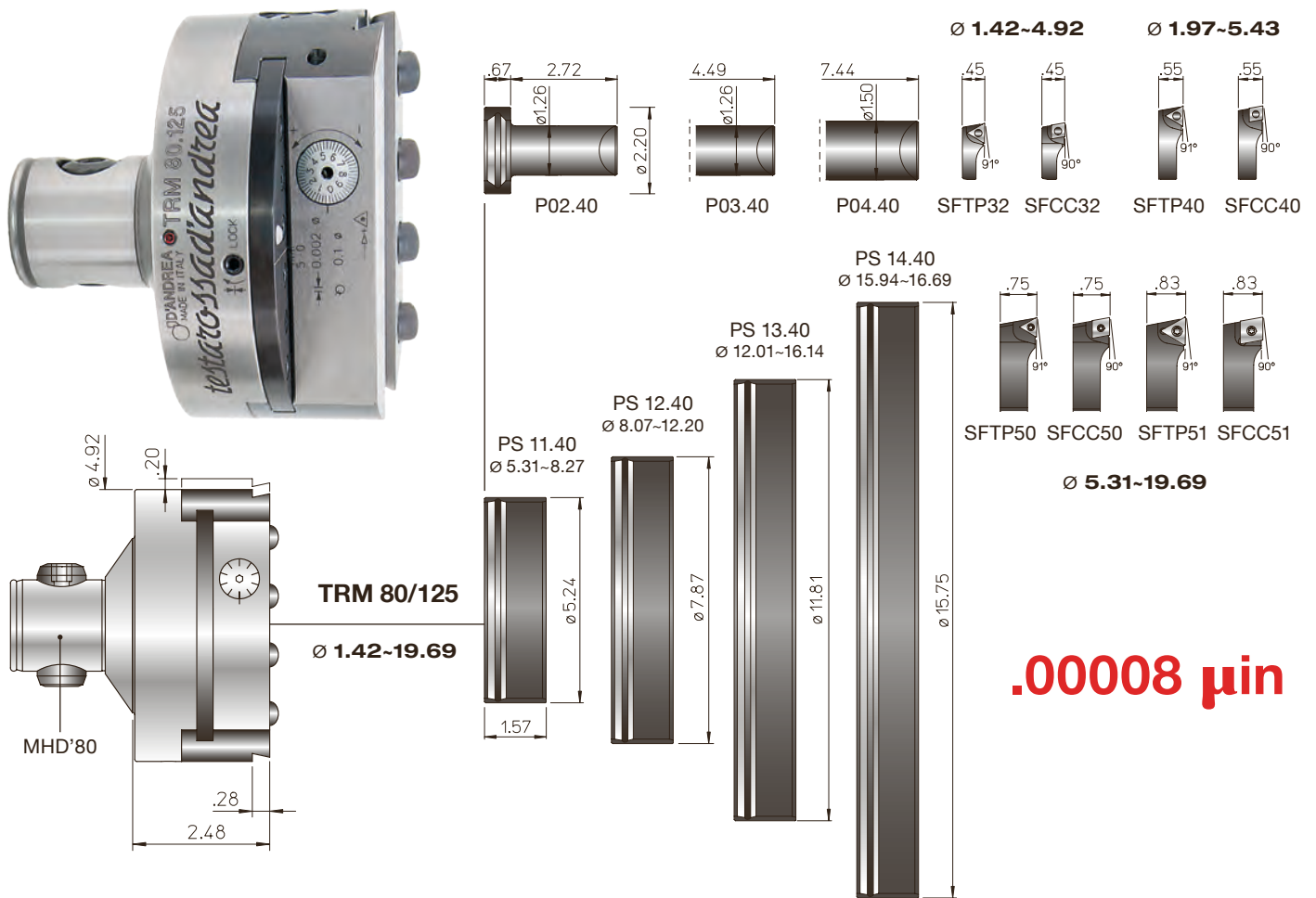

REF.	CODE	lb		
TRM 80/125 INCH	455008061251	12.13		
P02.40	431040320700	1.54		
P03.40	431040321150	2.20		
P04.40	431040321900	4.41		

REF.	CODE	lb		
PS 11.40	433040351500	3.31		
PS 12.40	433040352300	5.29		
PS 13.40	433040353300	7.72		
PS 14.40	433040354000	10.14		

KIT K03 \varnothing 1.42 ~ 16.14

TRM 80/125 EXCLUDED



- 1 PS11.40
- 1 PS12.40
- 1 PS13.40
- 1 P02.40
- 1 P03.40
- 1 P04.40
- 1 SFTP32
- 1 SFTP40
- 1 SFTP50

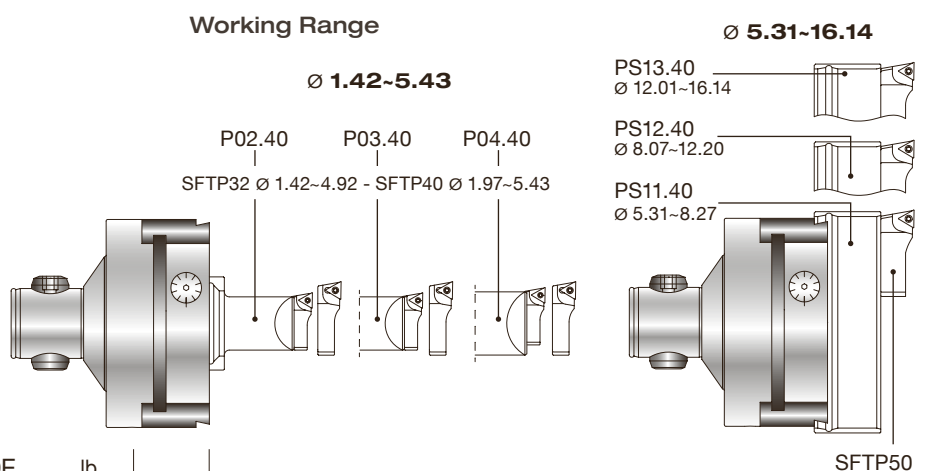

REF.	CODE	lb		
KIT K03 TRM 80/125	655012500030	11.2		

REF.	CODE	\triangle	\square	TORX T	lb		
SFTP32	470500532001	TPGX 0902..	CS 250T	08	0.04		
SFTP40	470500540001	TPGX 1103..	CS300890T	08	0.08		
SFTP50	470500550001	TPGX 1103..	CS300890T	08	0.18		
SFTP51	470500550003	TCMT 16T3..	TS 4	15	0.20		

REF.	CODE	\square	\square	TORX T	lb		
SFCC32	470500532002	CCGT 0602..	TS 25	08	0.04		
SFCC40	470500540002	CCGT 09T3..	TS 4	15	0.09		
SFCC50	470500550002	CCGT 09T3..	TS 4	15	0.18		
SFCC51	470500550004	CCMT 1204..	TS 5	25	0.20		

• For back-facing machining see p.23

MHD' TS/PSC TS INCH

TS 16/16
Ø .79~.94

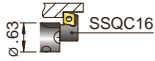

TS 20/20
Ø .93~1.18

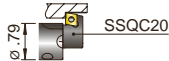

TS 25/25
Ø 1.16~1.57



TS 32/32
Ø 1.54~2.05

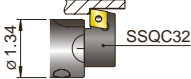

TS 40/40
Ø 2.01~2.76

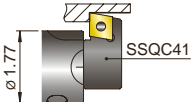

TS 50/50
Ø 2.72~3.62

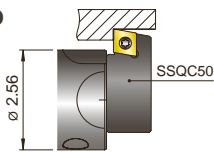

TS 50/63
TS 63/63
Ø 3.58~4.80

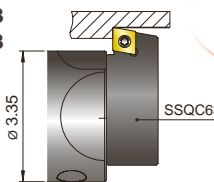

BHT
250 Ø 10.75~16.30
500 Ø 20.59~26.14
750 Ø 30.43~35.98

TS 80/80
SSQC80
Ø 4.76~6.38

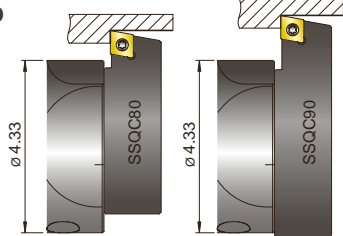

SSQC90
Ø 6.34~7.95

TS 80/90
SSQC90
Ø 6.34~9.92

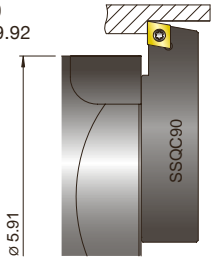

TRM INCH

TRM 16 Ø .79~.98



TRM 20 Ø .96~1.26



TRM 25 Ø 1.24~1.59

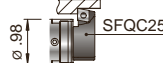

TRM 32 Ø 1.52~2.03

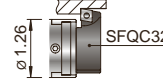

TRM 40 Ø 1.99~2.56

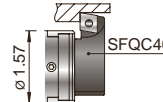

TRM 50 Ø 2.20~5.59
TRE 50 Ø 2.20~5.67

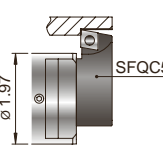

TRM INCH

BHT
250 Ø 9.96~19.88
500 Ø 19.80~29.72
750 Ø 29.65~39.57

TRM 50/63
TRM 63/63

PS 11.30 PS 12.30
Ø 3.23~4.02 Ø 3.94~6.10

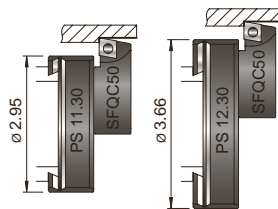

CALCULATION FORMULA FOR MINIMUM ENTERING Ø

$$B \varnothing \text{ min} = (\varnothing C + \varnothing A + 1) : 2$$

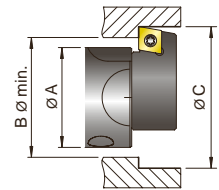

CARTRIDGE DIMENSIONS

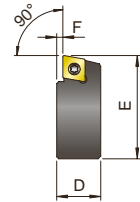

TRM 50/80
TRM 80/80

PS 12.30 PS 13.30
Ø 3.94~5.59 Ø 5.59~6.38

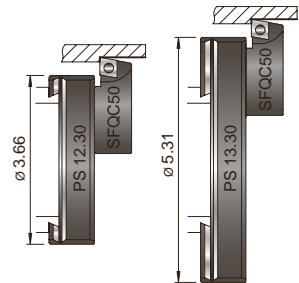

TRM 80/125

PS 11.40
Ø 5.51~8.35
PS 12.40
Ø 8.27~12.28
PS 13.40
Ø 12.20~16.22
PS 14.40
Ø 16.14~19.76

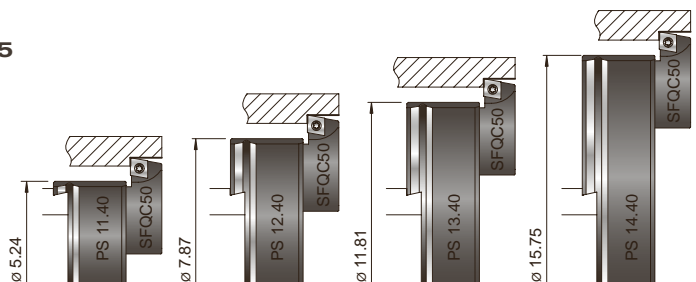

REF.	CODE	D	E	F	CCMT	TS	TORX T
SSQC 16	470500516261	10	16	2	0602..	25	08
SSQC 20	470500520261	11	19.5	1.5	0602..	25	08
SSQC 25	470500525261	14.5	24	2.5	0602..	25	08
SSQC 33	470500533261	17	32	3	09T3..	4	15
SSQC 41	470500541261	21	42	3.5	1204..	5	25
SSQC 50	470500550261	24.5	57	3.5	1204..	5	25
SSQC 63	470500563261	28.5	76	3.5	1204..	5	25
SSQC 80	470500580261	31.5	101	3.5	1204..	5	25
SSQC 90	470500590261	31.5	122	3.5	1204..	5	25

REF.	CODE	D	E	F	CCMT	TS	TORX T
SFQC 16	470500516062	10	18	2	0602..	25	08
SFQC 20	470500520062	10.5	22.5	2	0602..	25	08
SFQC 25	470500525062	12	28.5	2.5	0602..	25	08
SFQC 32	470500532062	13.5	35.5	2.5	0602..	25	08
SFQC 40	470500540062	16.5	46	3	09T3..	4	15
SFQC 50	470500550062	20.5	53	3	09T3..	4	15

PE COLLETS CHUCKING TOOLS

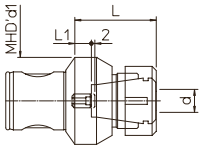

Supplied without collets and clamping wrenches

REF.	CODE	MHD' d1	d	L	L1	lb			N·m		
PE 20 / ER16M	655702000160	20	0.5-10	32	1	.13	ER-16M	E16M	40		
PE 32 / ER25M	655703200250	32	1-16	42	1.5	.55	ER-25M	E25M	160		
PE 40 / ER25	655704000250	40	1-16	45	5	.88	UM/ER25	E25	200		
PE 50 / ER25	655705000250	50	1-16	48	7	1.54	UM/ER25	E25	200		
PE 50 / ER32	655705000320	50	2-20	55	8	2.20	UM/ER32	E32	220		
PE 63 / ER32	655706300320	63	2-20	59	12	2.87	UM/ER32	E32	220		

FORCE INCH / METRIC MILLING POWER CHUCK

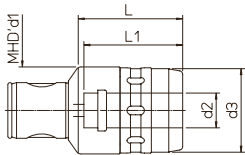

Supplied without collets and clamping wrenches

REF.	CODE	MHD' d1	d2	d3	L	L1	lb		
FORCE 50 3/4	656365000200	50	3/4	1.89	2.36	2.36	2.20		
FORCE 63 1-1/4	656366300320	63	1-1/4	2.60	3.14	2.36	4.41		
FORCE 50/20	656305000200	50	20	48	60	60	2.20		
FORCE 63/32	656306300320	63	32	66	80	80	4.41		

AW METRIC WELDON WHISTLE NOTCH CHUCKING TOOLS

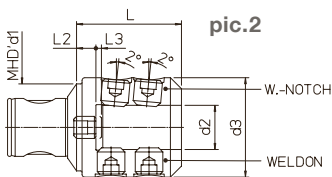
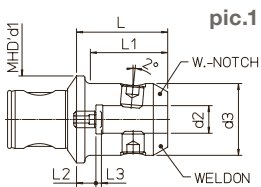

REF.	CODE	MHD' d1	d2 ^{H5}	d3	L	L1	L2	L3	lb	pic.		
AW 50/6	655805000060	50	6	25	44	32.5	7	2	1.10	1		
AW 50/8	655805000080	50	8	28	44	33	7	2	1.10	1		
AW 50/10	655805000100	50	10	35	52	42	11	3	1.54	1		
AW 50/12	655805000120	50	12	42	57	48	11	3	1.76	1		
AW 50/14	655805000140	50	14	42	57	48	11	3	1.76	1		
AW 50/16	655805000160	50	16	48	67	61	17	4	2.43	1		
AW 50/20	655805000200	50	20	51	67		16	4	2.65	1		
AW 50/25	655805000250	50	25	63	80		22	4	3.97	2		
AW 63/16	655806300160	63	16	48	64	53	14	4	3.09	1		
AW 63/20	655806300200	63	20	52	66	56	14	4	3.31	1		
AW 63/25	655806300250	63	25	64	74		16	4	4.63	2		
AW 63/32	655806300320	63	32	72	76		14	4	5.51	2		
AW 80/40	655808000400	80	40	80	83		12	4	7.05	2		

PF INCH DISC AND FACING CUTTER HOLDERS

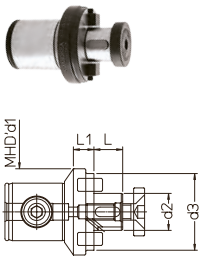

REF.	CODE	MHD' d1	d2	d3	L	L1	lb		
PF 50 3/4	655905061900	50	.750	1.57	.68	.59	1.1		
PF 50 1	655905062540	50	1.000	1.96	.68	.59	1.32		
PF 63 1	655906362540	63	1.000	2.36	.68	.59	2.2		
PF 63 1-1/4	655906363170	63	1.250	2.75	.68	.75	2.87		
PF 80 1-1/2	655908063810	80	1.500	3.46	.94	.94	4.85		
PF 80-2	655908065080	63	200	2.85	.94	1.06	6.61		

PF METRIC DISC AND FACING CUTTER HOLDERS

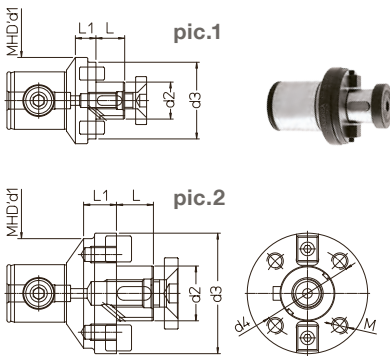

REF.	CODE	MHD' d1	d2	d3	d4	M	L	L1	lb	pic.		
PF 40/16	655904020165	40	16	32			17	15	.66	1		
PF 40/22	655904020225	40	22	40			19	13	.88	1		
PF 50/16	655905000160	50	16	32			17	15	1.10	1		
PF 50/22	655905000220	50	22	40			19	15	1.10	1		
PF 50/27	655905000270	50	27	50			21	15	1.32	1		
PF 50/32	655905000320	50	32	60			24	15	1.54	1		
PF 63/22	655906300220	63	22	60			19	15	1.98	1		
PF 63/27	655906300270	63	27	60			21	15	2.43	1		
PF 63/32	655906300320	63	32	63			24	15	2.65	1		
PF 80/32	655908000320	80	32	80			24	24	3.75	1		
PF 80/40	655908000400	80	40	84	66.7	M12	27	24	4.19	2		
PF 80/50	655908000500	80	50	90			30	24	4.41	2		
PF 80/60	655908000600	80	60	128.5	101.6	M16	40	31.5	7.72	2		

MHD' 80 - HT 8 CHUCKING TOOLS MHD' 80 - HT 8

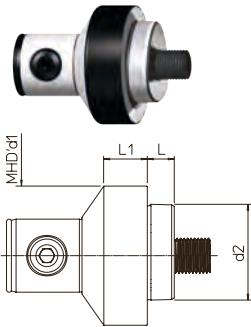

REF.	CODE	MHD' d1	d2	L	L1	lb		
MHD'80-HT8	655108000080	80	HT8	15.5	25	4.41		

NS SEMIFINISHED CHUCK HOLDERS

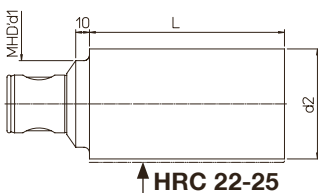

REF.	CODE	MHD' d1	d2	L	lb		
NS 50	657205001600	50	63	160	9.26		
NS 63	657206302000	63	80	200	19.18		
NS 80	657208002500	80	100	250	35.27		

PSC COUPLING ISO 26623-1/2

Line of high-precision monolithic and modular tool holders that allows to perform different operations on the machine-tools.

The strong point of the **PSC** system is the ISO 26623 polygonal-conical connection which guarantees extreme rigidity even in the most demanding process.

The system allows the use of the entire **MHD'** line.

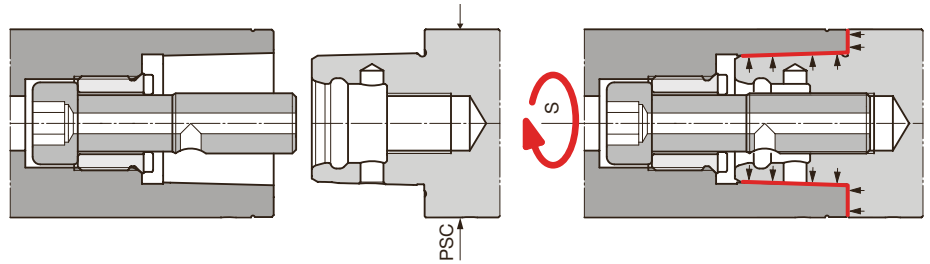

PSC	S 	lbf.in
40	8	486.79
50	10	840.82
63-80	14	1504.63

The **PSC coupling**, compliant with the ISO 26623 standard, is available in four sizes. The system is complete with arbors, extensions, reductions, adapters, roughing and finishing heads. The range includes collet chuck ER and power chucks MONOFORCE holders.



PSC - TS complete line of double-bit boring heads for roughing from \varnothing 2.68 to \varnothing 7.87.



PSC - TRM complete line of micrometric heads for finishing from \varnothing .10 to \varnothing 8.66.



ARBORS, manufactured in 4 different sizes **PSC 40-50-63 and 80**, are made of case-hardened, tempered and subsequently ground steel.



PSC - PR e RD for each size of PSC, extensions and reductions are available in different lengths which allow to achieve the required working depths.



MONOforce line of high precision power milling chucks ideal for machining where precision and high clamping forces for the cutting tool are required.



PSC - ER collet holders made for the use of ER standard collets.



PF adapters for side and face milling cutters.



PSC - MHD' adapters to integrate the entire MHD' system boring line into the PSC program.

PSC - PR
Extensions
PSC - RD
Reductions

- PSC50 - PR50
- PSC50 - RD50
- PSC63 - PR63
- PSC63 - RD63
- PSC80 - PR80

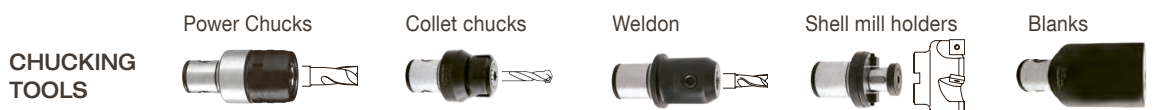
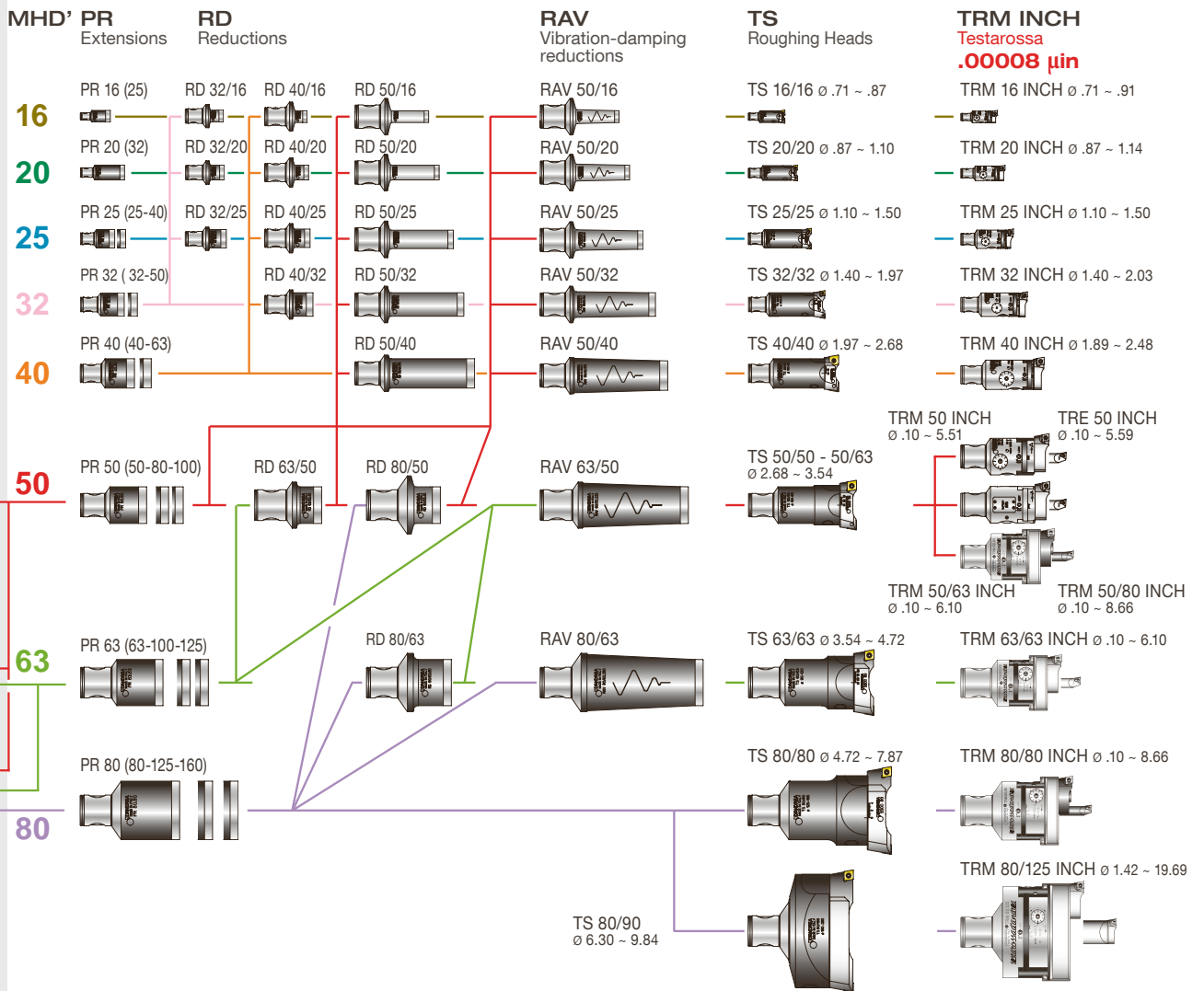
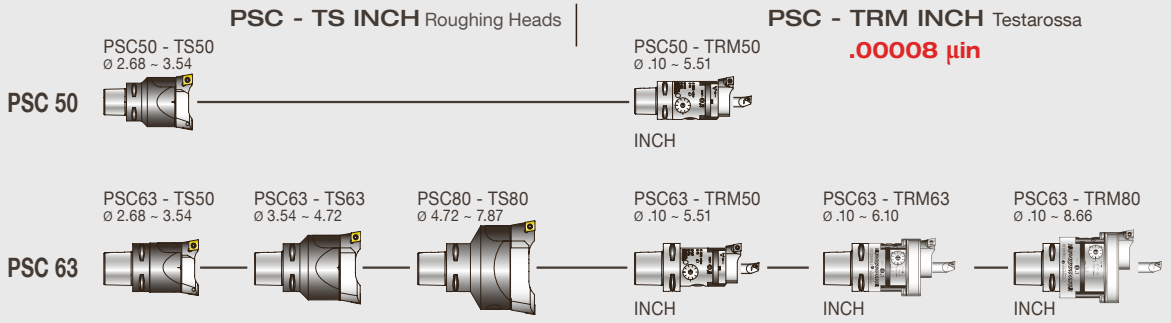

DIN-AD - PSC DIN 69871 / ISO 26623-2

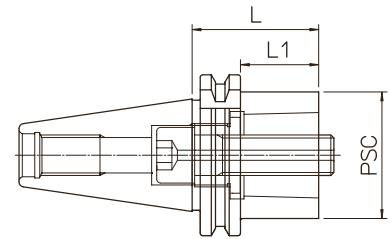
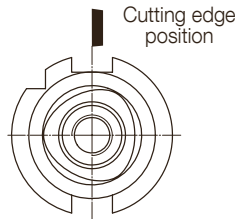

DIN	REF.	CODE	PSC	L	L1	lb		
40	DIN69871-AD40 PSC 50.40	41PS05014028	50	1.57	.83	1.98		
50	DIN69871-AD50 PSC 50.30	41PS05015020	50	1.18	.43	5.95		
50	DIN69871-AD50 PSC 63.30	41PS06315028	63	1.18	.43	6.17		
50	DIN69871-AD50 PSC 80.70	41PS08015020	80	2.76	2.01	8.16		

MAS BT-AD - PSC MAS 403 BT / ISO 26623-2

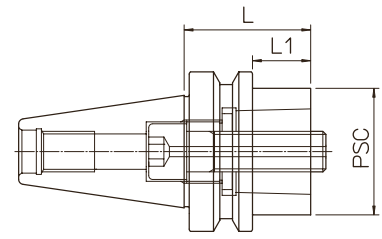
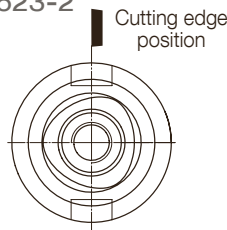

BT	REF.	CODE	PSC	L	L1	lb		
40	MAS403 BT40-AD PSC 50.50	41PS05014032	50	1.97	.91	2.65		
50	MAS403 BT50-AD PSC 50.40	41PS05015030	50	1.57	.08	7.50		
50	MAS403 BT50-AD PSC 63.50	41PS06315032	63	1.97	.47	7.72		
50	MAS403 BT50-AD PSC 80.70	41PS08015030	80	2.76	1.26	8.82		

HSK-T - PSC DIN 69893 / ISO 26623-2

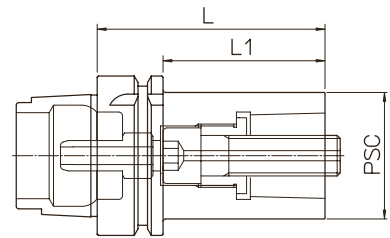
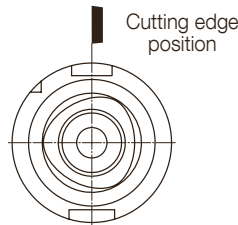

HSK-T	REF.	CODE	PSC	L	L1	lb	Supplied with coolant tube	
63	HSK-T63 PSC 40.80	41PS0405632T	40	3.15	2.13	2.43		
63	HSK-T63 PSC 50.90	41PS0505632T	50	3.54	2.52	3.31		
100	HSK-T100 PSC 50.100	41PS0505992T	50	3.94	2.80	6.61		
100	HSK-T100 PSC 63.110	41PS0635992T	63	4.33	3.19	7.94		
100	HSK-T100 PSC 80.120	41PS0805992T	80	4.72	3.58	10.36		

CAT-AD - PSC ANSI B5.50 / ISO 26623-2

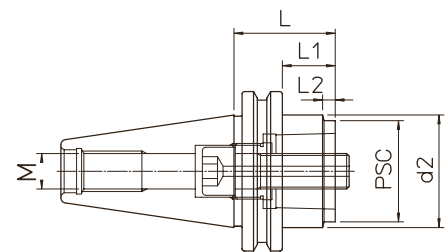
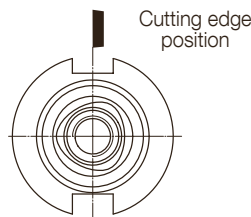

CAT	REF.	CODE	PSC	d2	L	L1	L2	M	lb		
40	CAT40 AD PSC 50.50	41PS05014045	50		1.97	1.22		UNC 5/8-11	2.20		
50	CAT50 AD PSC 50.40	41PS05015045	50	2.75	1.57	.83	.20	UNC 1/8	5.51		
50	CAT50 AD PSC 63.50	41PS06315045	63	2.76	1.97	1.22	.49	UNC 1/8	6.61		
50	CAT50 AD PSC 80.100	41PS08015045	80		3.94	3.19		UNC 1/8	10.14		

PSC - PR ISO 26623-1 / 2

EXTENSIONS

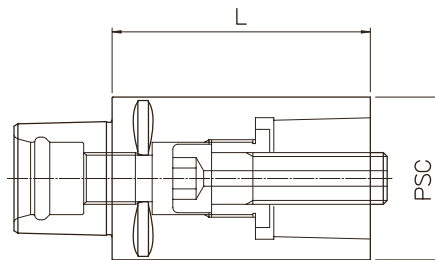
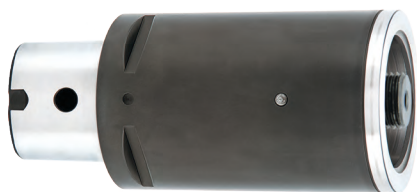

PSC	REF.	CODE	L	lb		
40	PR PSC 40.60	656PS04006000	2.36	1.21		
50	PR PSC 50.80	656PS05008000	3.15	2.43		
63	PR PSC 63.100	656PS06310000	3.94	4.85		
80	PR PSC 80.100	656PS08010000	3.94	7.94		

PSC - RD ISO 26623-1 / 2

REDUCTIONS

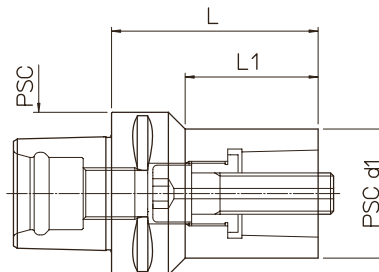

PSC	REF.	CODE	PSCd1	L	L1	lb		
50	RD PSC 50/40.65	657PS05004000	40	2.56	1.77	1.54		
63	RD PSC 63/40.80	657PS06304000	40	3.15	2.02	2.87		
63	RD PSC 63/50.80	657PS06305000	50	3.15	2.03	3.31		
80	RD PSC 80/50.80	657PS08005000	50	3.15	1.94	4.85		
80	RD PSC 80/63.80	657PS08006300	63	3.15	2.09	5.51		

PSC - MHD' ISO 26623-1

REDUCTIONS TO MODULAR

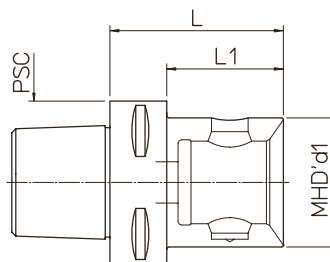

PSC	REF.	CODE	MHD' d1	L	L1	kg		
50	PSC 50 - MHD' 50.55	416502605005	50	2.17		1.76		
63	PSC 63 - MHD' 40.50	416402606305	40	1.97	1.10	1.98		
63	PSC 63 - MHD' 50.55	416502606305	50	2.17	1.30	1.76		
63	PSC 63 - MHD' 63.77	416632606307	63	3.03		1.8		
80	PSC 80 - MHD' 50.60	416502608006	50	2.36	1.18	3.97		
80	PSC 80 - MHD' 63.70	416632608007	63	2.76	1.57	5.07		
80	PSC 80 - MHD' 80.75	416802608007	80	2.95		5.73		

On request supplied with coolant tube **PSC**. See p.55 

PSC - TS \varnothing 2.68 ~ 7.87

Simple and extremely rigid roughing heads, thanks to the serrated surfaces between the head body and the bit holders. The constant distance between the bit holder clamping screw and the cutting edge guarantees the stability of the system.

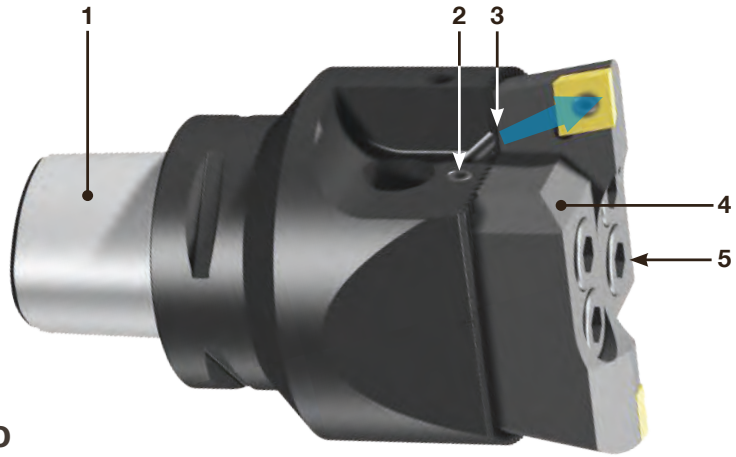

- 1. PSC 50 - 63 - 80
- 2. Setting screws
- 3. Coolant outlets **Max 580 PSI**
- 4. Bit holders
- 5. Tools clamp screws

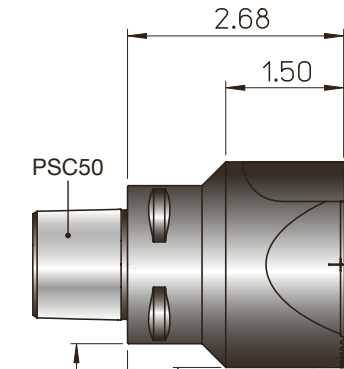

PSC50 - TS50
 \varnothing 2.68 ~ 3.54

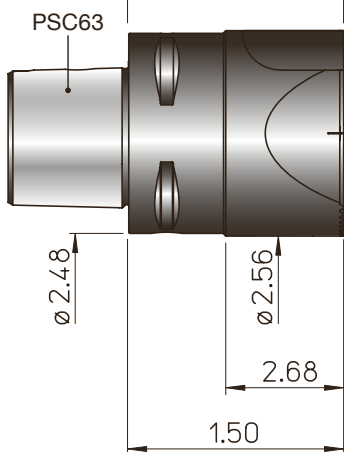
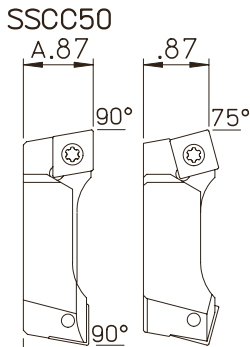

PSC63 - TS50
 \varnothing 2.68 ~ 3.54

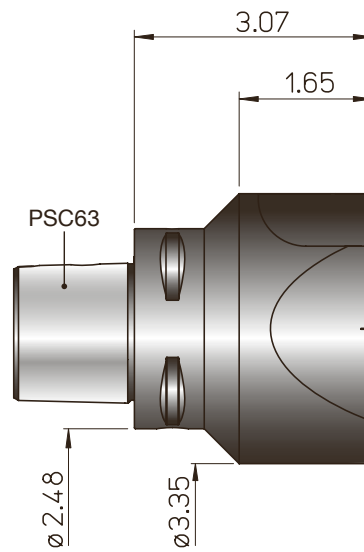

PSC63 - TS63
 \varnothing 3.54 ~ 4.72

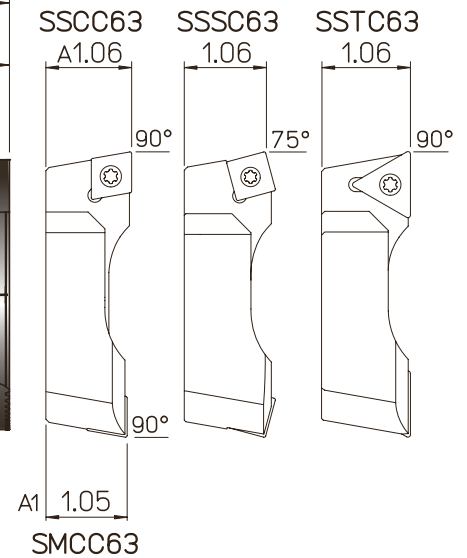

REF.	CODE	lb
PSC50 - TS50	71PSC050TS50090	3.09
PSC63 - TS50	71PSC063TS50090	3.97

REF.	CODE	lb
PSC63 - TS63	71PSC063TS63105	5.95
PSC63 - TS80	71PSC063TS80115	8.38

On request supplied with coolant tube **PSC**. See p.55



USE TS for ROUGHING end SEMI-FINISHING operations

Roughing and semi-finishing operations. Cutting edges might be adjusted on a pre-setting bench and TS heads can be used in three different configurations, with a single cutting edge (**pic. 3**) or misaligned ones (**pic.2**) half the feed.

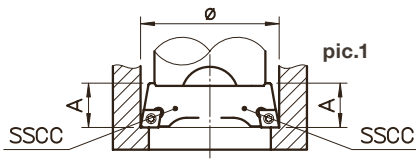

pic.1 with two SSCC bit holders aligned and on the same diameter for roughing operations with high feedrate.

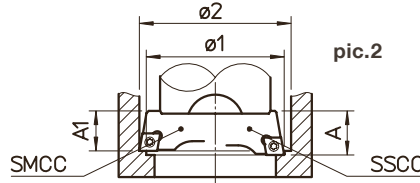

pic. 2 with one SSCC bit holder and one SMCC bit holder staggered and on a different diameter for roughing operations with high depth of cut.

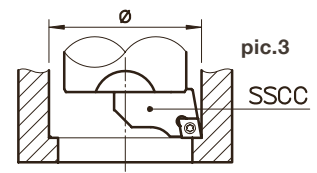

pic.3 with a single bit holder for roughing or semi-finishing operations.

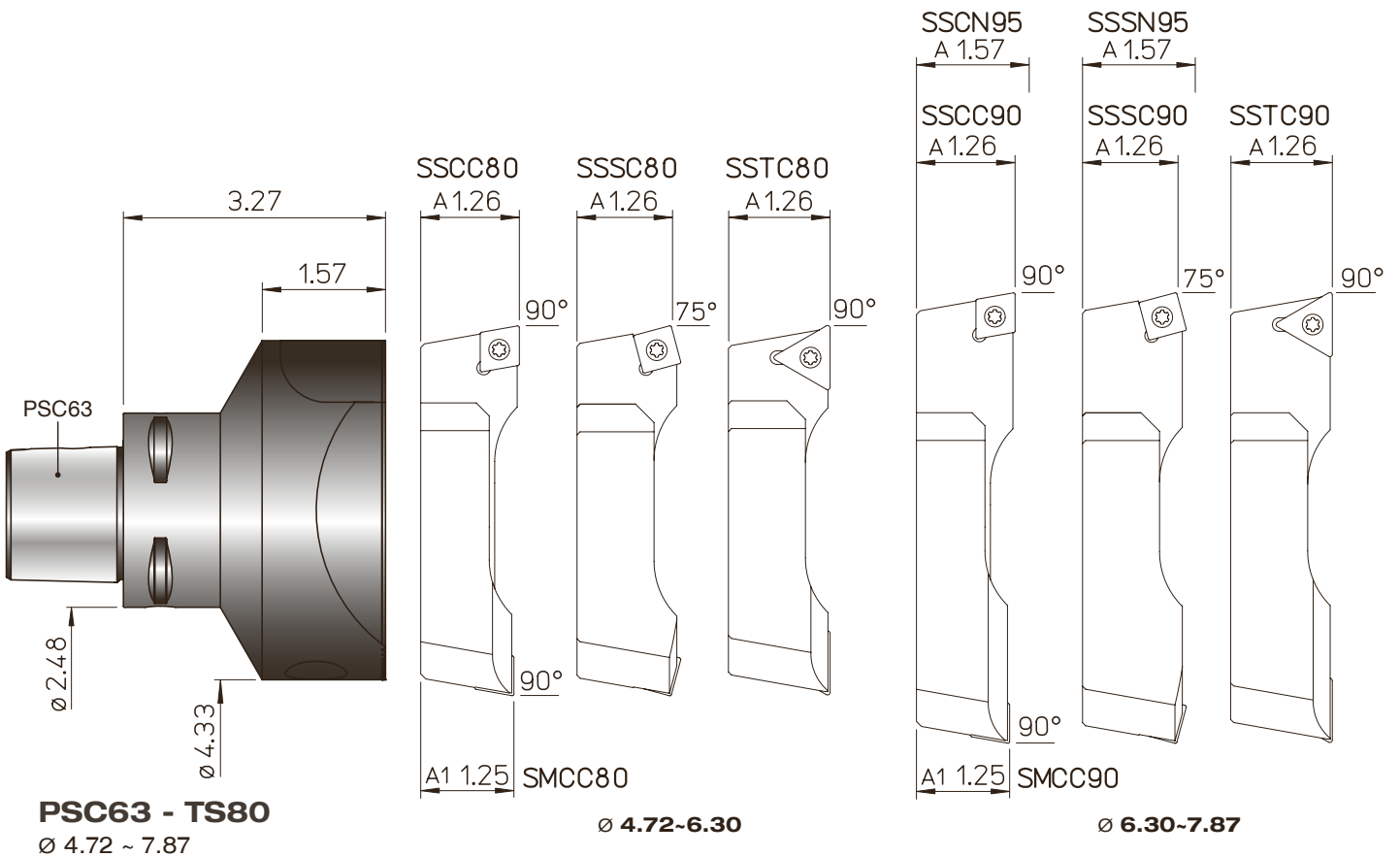

REF.	CODE		TS	TORX	T	lb
SSCC 50	470500550204	CCMT 1204..	5	25	0.22	
SSCC 63	470500563201	CCMT 1204..	5	25	0.44	
SSCC 80	470500580201	CCMT 1204..	5	25	1.10	
SSCC 90	470500590201	CCMT 1204..	5	25	1.54	
SSCN 95	470500595201	CNM. 1906..			1.98	
SSTC 63	470500563206	TCMT 2204..	5	25	0.44	
SSTC 80	470500580206	TCMT 2204..	5	25	1.10	
SSTC 90	470500590206	TCMT 2204..	5	25	1.54	

REF.	CODE		TS	TORX	T	lb
SMCC 50	470500550205	CCMT 1204..	5	25	0.22	
SMCC 63	470500563203	CCMT 1204..	5	25	0.44	
SMCC 80	470500580203	CCMT 1204..	5	25	1.10	
SMCC 90	470500590203	CCMT 0602..	25	08	1.54	
SSSC 50	470500550202	SCMT 1204..	5	25	0.13	
SSSC 63	470500563202	SCMT 1204..	5	25	0.44	
SSSC 80	470500580202	SCMT 1204..	5	25	1.10	
SSSC 90	470500590202	SCMT 1204..	5	25	1.54	
SSSN 95	470500595202	SNM. 1906..			p.51 1.98	

• For back-facing machining see p.23

PSC - ER

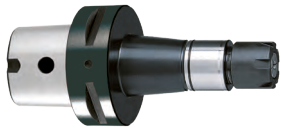

PSC - FORCE



PSC - PF



PSC - NS



PSC - ER

COLLETS CHUCKING TOOLS

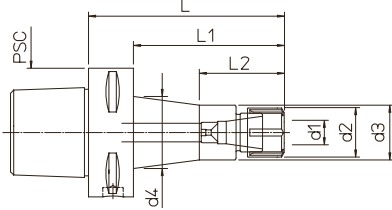

PSC	REF.	CODE	ER	d1	d2	d3	d4	L	L1	L2	lb
50	PSC50 - ER16.55	71PSC-050ER1605	16M	0.5-10	22	24		55	35	26	1.10
50	PSC50 - ER25.65	71PSC-050ER2506	25	1-16	42			65	45		1.76
63	PSC63 - ER16.60	71PSC-063ER1606	16M	0.5-10	22	24		60	38		1.87
63	PSC63 - ER16.120	71PSC-063ER1612	16M	0.5-10	22	24	31	120	98	33	2.43
63	PSC63 - ER25.65	71PSC-063ER2506	25	1-16	42			65	43	37	2.43
63	PSC63 - ER25.140	71PSC-063ER2514	25	1-16	42		47.5	140	118	43.5	4.19
63	PSC63 - ER32.75	71PSC-063ER3207	32	2-20	50			75	53		3.31
63	PSC63 - ER32.160	71PSC-063ER3216	32	2-20	50			160	138		5.51
80	PSC80 - ER25.70	71PSC-080ER2507	25	1-16	42			70	40		4.63
80	PSC80 - ER32.75	71PSC-080ER3207	32	2-20	50			72	45		5.51

Supplied without collets and clamping wrenches
Chip prearrangement

PSC - FORCE

MILLING POWER CHUCKS

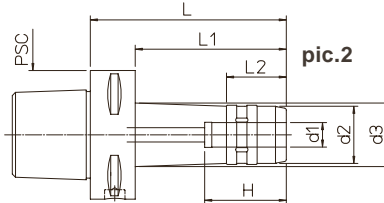
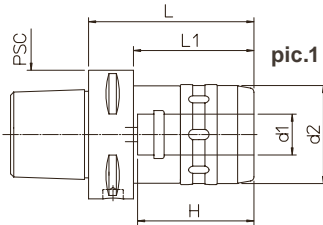

Without clamping wrench - Chip prearrangement

PSC - KIT K01

MONOforce 20-32

- 1 RC 20.06 1 RC 20.12 1 RC 32.06 1 RC 32.16
- 1 RC 20.08 1 RC 20.16 1 RC 32.08 1 RC 32.20
- 1 RC 20.10 1 CHV 50 1 RC 32.10 1 RC 32.25
- 1 RC 32.12 1 CHV 75



MF 20



MF 32

PSC	REF.	CODE	d1	d2	d3	H	L	L1	L2	lb	pic.
63	PSC 63 - MF 12.100	71PSC-063MF1210	12	28	31.5	46	100	78	29.5	3.09	2
63	PSC 63 - MF 20.80	71PSC-063MF2008	20	48	60	80	58			2.87	1
63	PSC 63 - MF 32.100	71PSC-063MF3210	32	66	80	100				4.63	1
80	PSC 80 - MF 20.80	71PSC-080MF2008	20	48	60	80	50			8.16	1
80	PSC 80 - MF 32.100	71PSC-080MF3210	32	66	80	100	70			9.70	1

PSC	REF.	CODE	lb
63	KIT K01 MONOFORCE 20.80 PSC63	7KPSC-063MF2008	5.07
63	KIT K01 MONOFORCE 32.100 PSC63	7KPSC-063MF3210	10.14
80	KIT K01 MONOFORCE 20.80 PSC80	7KPSC-080MF2008	11.90
80	KIT K01 MONOFORCE 32.100 PSC80	7KPSC-080MF3210	16.53

PSC - PF

SHELL MILL HOLDERS

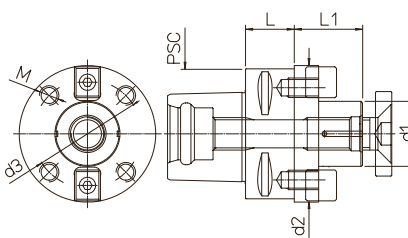

PSC	REF.	CODE	d1	d2	d3	M	L	L1	lb
50	PSC 50 - PF 3/4	71PSC-650PF1900	.750	1.57			.98	.59	1.10
63	PSC 63 - PF 1	71PSC-663PF2540	1.000	2.36			.98	.59	1.76
63	PSC 63 - PF 1-1/4	71PSC-663PF3170	1.250	2.75			.98	.75	1.98
80	PSC 80 - PF 1-1/2	71PSC-680PF3810	1.500	3.46			1.18	.94	3.97
50	PSC 50 - PF22.25	71PSC-050PF2202	22				25	19	1.10
50	PSC 50 - PF27.25	71PSC-050PF2702	27				25	21	1.32
63	PSC 63 - PF27.25	71PSC-063PF2702	27				25	21	1.76
63	PSC 63 - PF32.25	71PSC-063PF3202	32				25	24	1.98
80	PSC 80 - PF32.30	71PSC-080PF3203	32				30	24	3.97
80	PSC 80 - PF40.45	71PSC-080PF4004	40	84	66.7	M12	45	27	5.29

PSC - NS

SEMIFINISHED CHUCK HOLDERS

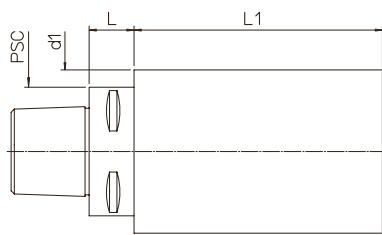

HRC42

PSC	REF.	CODE	d1	L	L1	lb
50	PSC 50 - NS 63.160/140	71PSC050Z406314	63	20	140	8.38
50	PSC 50 - NS 80.160/140	71PSC050Z408014	80	20	140	22.49
50	PSC 50 - NS 100.180/160	71PSC050Z410016	100	22	160	13.01
63	PSC 63 - NS 80.162/140	71PSC063Z408014	80	22	140	13.67
63	PSC 63 - NS 100.182/160	71PSC063Z410016	100	22	160	22.93
63	PSC 63 - NS 120.202/180	71PSC063Z412018	120	22	180	37.48
80	PSC 80 - NS 100.190/160	71PSC080Z410016	100	30	160	25.35

On request supplied with coolant tube **PSC**. See p.55



PSC - TRM \varnothing .10 ~ 7.87

PSC50 - TRM50 INCH RPM 8.000

PSC63 - TRM50 INCH RPM 8.000

PSC63 - TRM63 INCH RPM 6.000

PSC63 - TRM80 INCH RPM 5.000

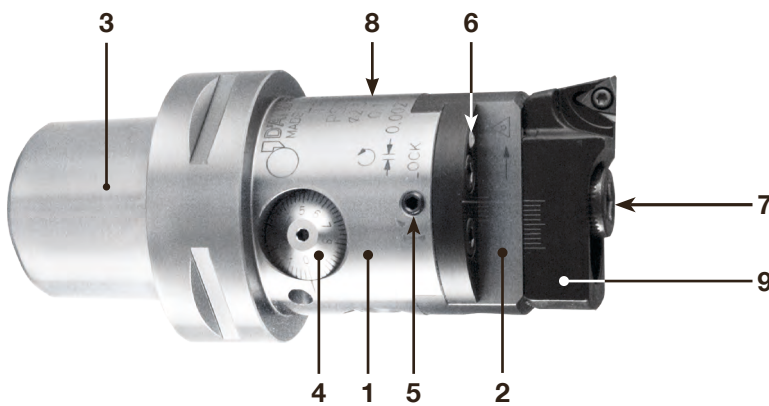

TRM heads allow high precision machining and excellent surface finish in **IT6** grade of tolerance. The adjustment sensitivity of **.00004 μ m** on the radius is easily readable on the vernier scale and can also be performed in the machine.

.00008 μ m

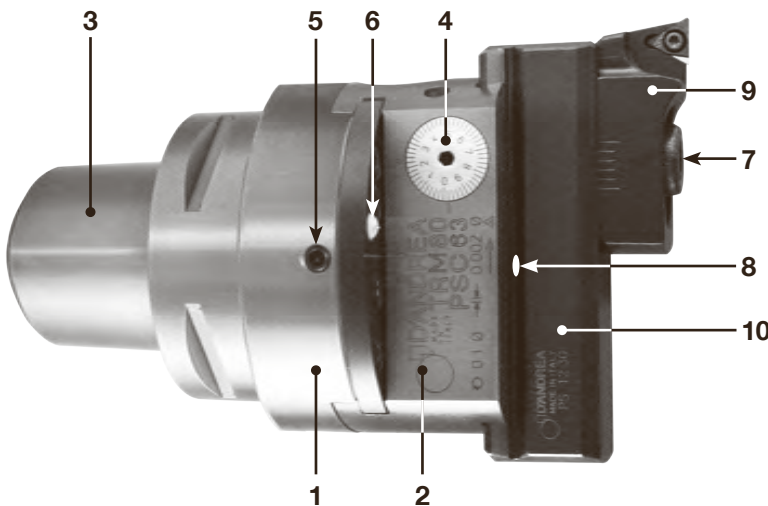

- 1. Body
- 2. Slide toolholder
- 3. **PSC 50-63-80**
- 4. Micrometric vernier scale
- 5. Slide clamp screw
- 6. Coolant outlet
Max 580 PSI
- 7. Tools clamp screws
- 8. Oiler
- 9. Bit holder
- 10. Tool holder

PSC50 - TRM50 INCH
 \varnothing .10 ~ 5.51

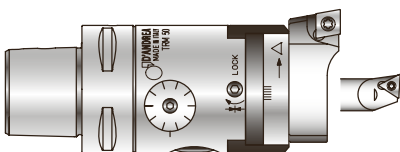

PSC63 - TRM50 INCH
 \varnothing .10 ~ 5.51

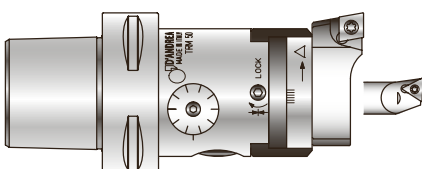

PSC63 - TRM63 INCH
 \varnothing .10 ~ 6.10

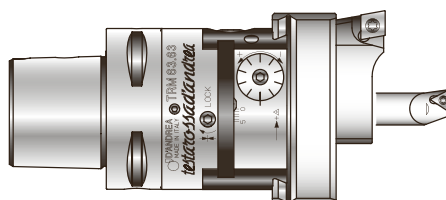

PSC63 - TRM80 INCH
 \varnothing .10 ~ 8.66

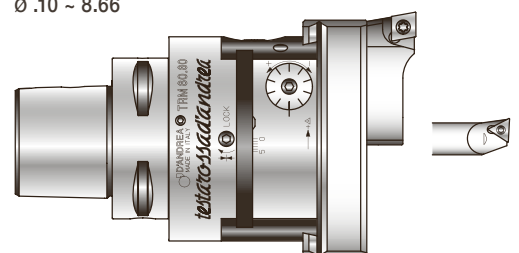

PSC50 - TRM50

Ø .10 ~ 5.51

PSC63 - TRM50

Ø .10 ~ 5.51



.00008 μin

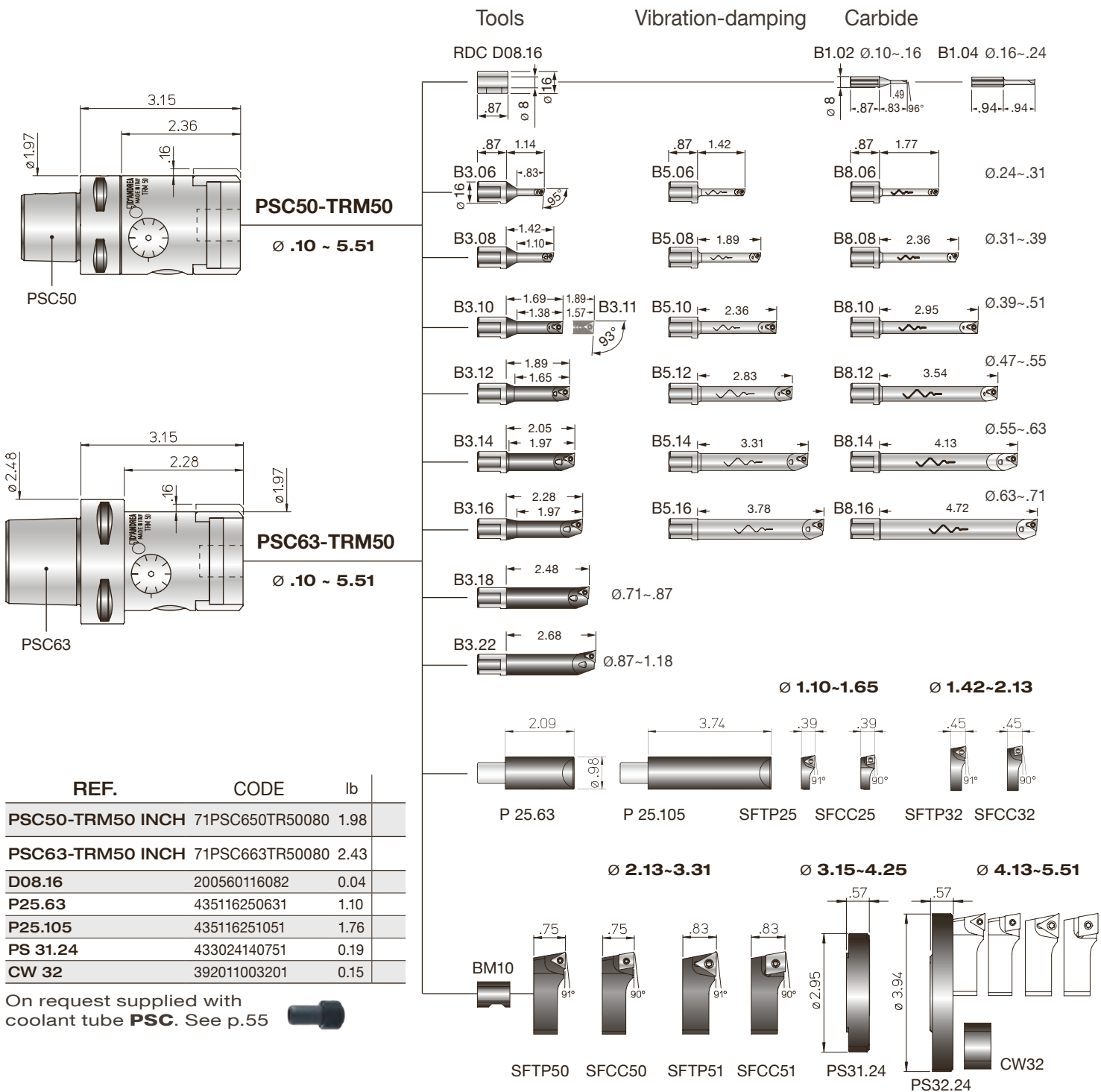

KIT K01 PSC50 - TRM50

Ø .10 ~ 5.51



1 PSC50-TRM50 1 SFTP 25
 1 B3.06 1 SFTP 32
 1 B3.08 1 SFTP 50
 1 B3.11 1 P 25.63
 1 B3.16 1 PS 31.24
 1 B3.22 1 PS 32.24
 1 CW 32

5 TPGX 090202L DC100
 1 TPGX 110302L DC100
 2 WCGT 020102L DC10

KIT K01 PSC63 - TRM50

Ø .10 ~ 5.51



1 PSC63-TRM50 1 SFTP 25
 1 B3.06 1 SFTP 32
 1 B3.08 1 SFTP 50
 1 B3.11 1 P 25.63
 1 B3.16 1 PS 31.24
 1 B3.22 1 PS 32.24
 1 CW 32

5 TPGX 090202L DC100
 1 TPGX 110302L DC100
 2 WCGT 020102L DC10

REF.	CODE	lb
KIT K01 PSC50-TRM50 INCH	7KPSC650TR50081	7.72

REF.	CODE	lb
KIT K01 PSC63-TRM50 INCH	7KPSC663TR50081	9.26

KIT K01 PSC50-TRM50 / PSC63-TRM50

Working Range

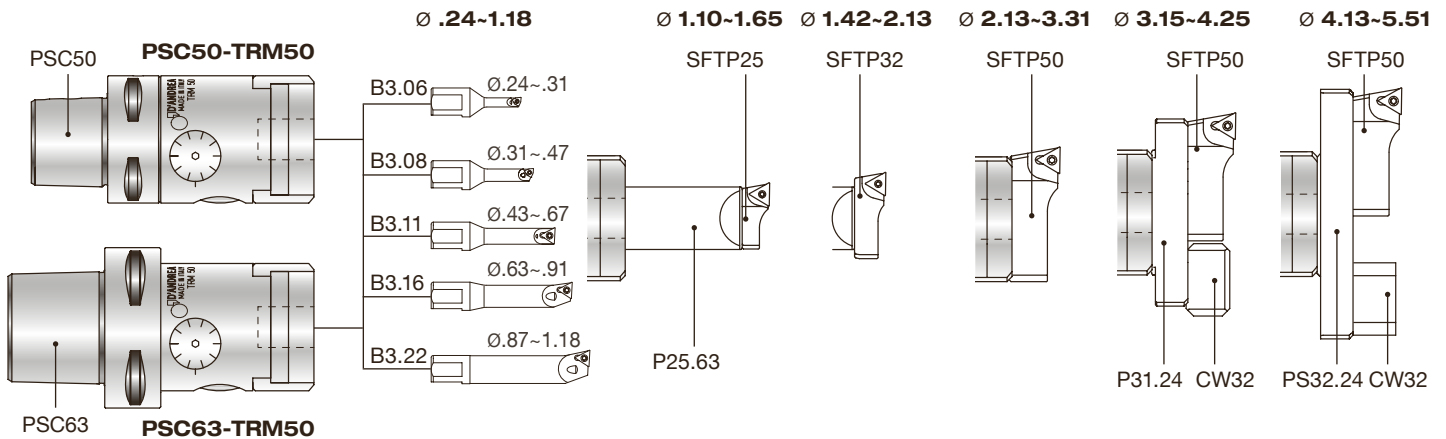

REF.	CODE	TORX T	lb
B1.02	572010502001		0.04
B1.04	572010504001		0.04
B3.06	572010506001	WCGT0201.. TS 21 06	0.08
B3.08	572010508001	WCGT0201.. TS 211 06	0.09
B3.10	572010510001	TPGX0902.. CS 250 T 08	0.11
B3.11	572010511001	TPGX0902.. CS 250 T 08	0.12
B3.12	572010512001	TPGX0902.. CS 250 T 08	0.06
B3.14	572010514001	TPGX0902.. CS 250 T 08	0.15
B3.16	572010516001	TPGX0902.. CS 250 T 08	0.15
B3.18	572010518001	TPGX0902.. CS 250 T 08	0.22
B3.22	572010522001	TPGX0902.. CS 250 T 08	0.22

REF.	CODE	TORX T	lb
B5.06	572010506105	WCGT0201.. TS 21 06	0.17
B5.08	572010508105	WCGT0201.. TS 211 06	0.20
B5.10	572010510105	TPGX0902.. CS 250 T 08	0.22
B5.12	572010512105	TPGX0902.. CS 250 T 08	0.22
B5.14	572010514105	TPGX0902.. CS 250 T 08	0.44
B5.16	572010516105	TPGX0902.. CS 250 T 08	0.3
B8.06	572010506108	WCGT0201.. TS 21 06	0.66
B8.08	572010508108	WCGT0201.. TS 211 06	0.18
B8.10	572010510108	TPGX0902.. CS 250 T 08	0.22
B8.12	572010512108	TPGX0902.. CS 250 T 08	0.44
B8.14	572010514108	TPGX0902.. CS 250 T 08	0.44
B8.16	572010516108	TPGX0902.. CS 250 T 08	0.66

REF.	CODE	TORX T	lb
SFTP25	470500525001	TPGX0902.. CS 250T 08	0.02
SFTP32	470500532001	TPGX0902.. CS 250T 08	0.09
SFTP50	470500550001	TPGX1103.. CS300890T 08	0.18
SFTP51	470500550003	TCMT16T3.. TS 4 15	0.20

REF.	CODE	TORX T	lb
SFCC25	470500525002	CCGT0602.. TS 25 08	0.02
SFCC32	470500532002	CCGT0602.. TS 25 08	0.04
SFCC50	470500550002	CCGT09T3.. TS 4 15	0.18
SFCC51	470500550004	CCMT1204.. TS 5 25	0.20

• For back-facing machining see p.23

PSC63 - TRM63

Ø .10 ~ 6.10



PSC63 - TRM80

Ø .10 ~ 8.66



.00008 μin

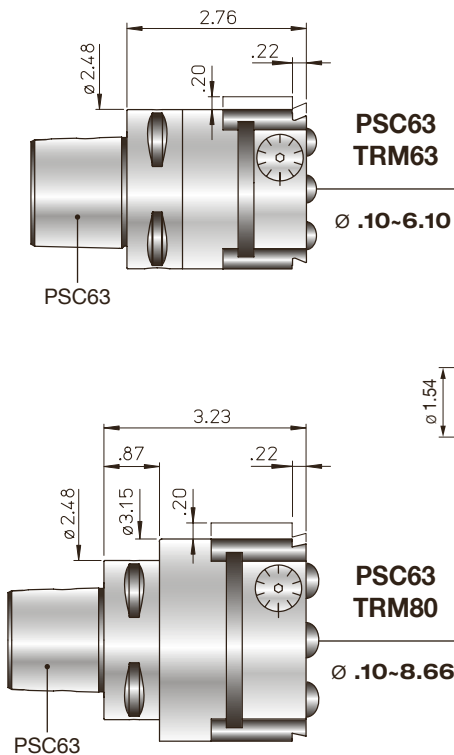

Tools

Vibration-damping

Carbide

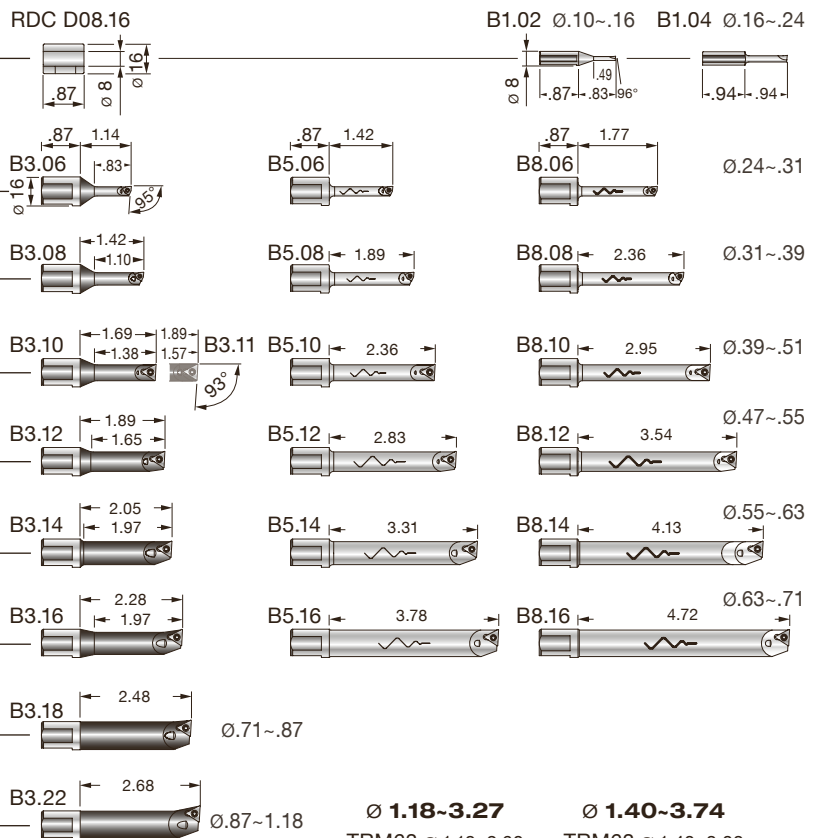

REF.	CODE	lb
PSC63-TRM63 INCH	71PSC663TR63080	3.31
PSC63-TRM80 INCH	71PSC663TR80080	4.41
D08.16	200560116082	0.04
P20.30	431030160300	0.44
P02.30	431030250400	0.66
P03.30	431030250700	0.88
P04.30	431030251150	1.54
PS 11.30	433030260750	0.88
PS 12.30	433030260950	1.10
PS 13.30	433030261400	1.54

On request supplied with coolant tube **PSC**. See p.55

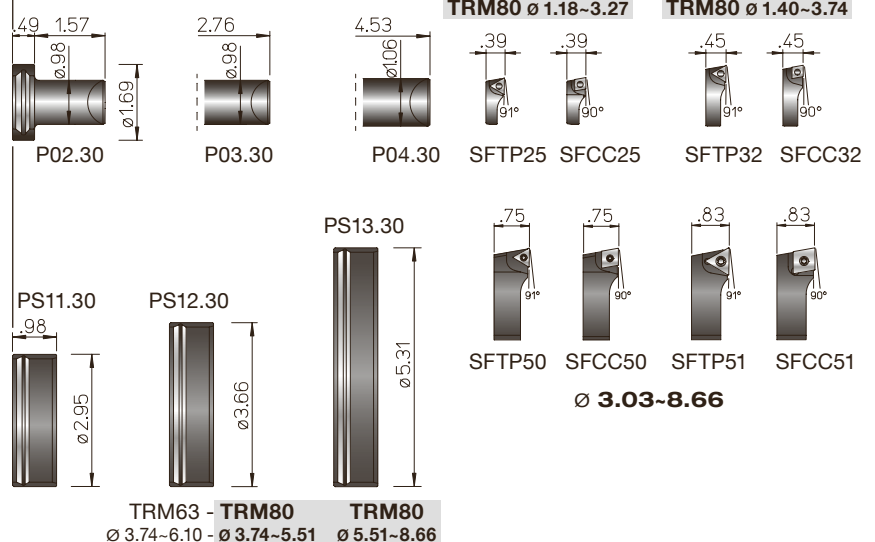

TRM63 - TRM80 TRM80
 Ø 3.74~6.10 - Ø 3.74~5.51 Ø 5.51~8.66

KIT K01 PSC63 - TRM63

Ø .24 ~ 6.10



1 PSC63 - TRM63

- 1 P20.30 1 B3.11
- 1 PS11.30 1 B3.16
- 1 PS12.30 1 B3.22
- 1 P02.30 1 SFTP25
- 1 P03.30 1 SFTP32
- 1 B3.06 1 SFTP50
- 1 B3.08
- 5 TPGX 090202L DC100
- 1 TPGX 110302L DC100
- 2 WCGT 020102L DC 10

KIT K01 PSC63 - TRM80

Ø .24 ~ 8.66



1 PSC63 - TRM80

- 1 P20.30 1 B3.08
- 1 PS12.30 1 B3.11
- 1 PS13.30 1 B3.16
- 1 P02.30 1 B3.22
- 1 P03.30 1 SFTP25
- 1 P04.30 1 SFTP32
- 1 B3.06 1 SFTP50
- 5 TPGX 090202L DC100
- 1 TPGX 110302L DC100
- 2 WCGT 020102L DC 10

REF.	CODE	lb
KIT K01 PSC63-TRM63 INCH	7KPSC663TR63080	5.5

REF.	CODE	lb
KIT K01 PSC63-TRM80 INCH	7KPSC663TR80080	6.5

KIT K01 PSC63 - TRM63

Working Range

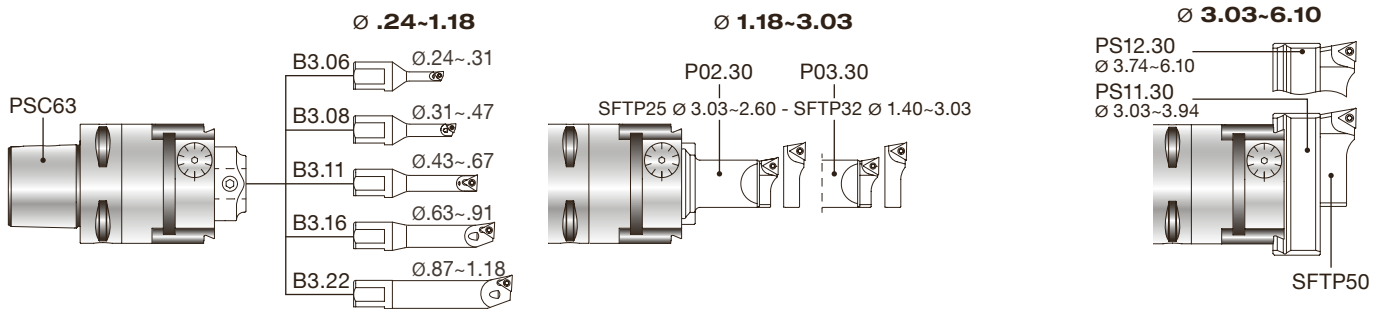

KIT K01 PSC63 - TRM80

Working Range

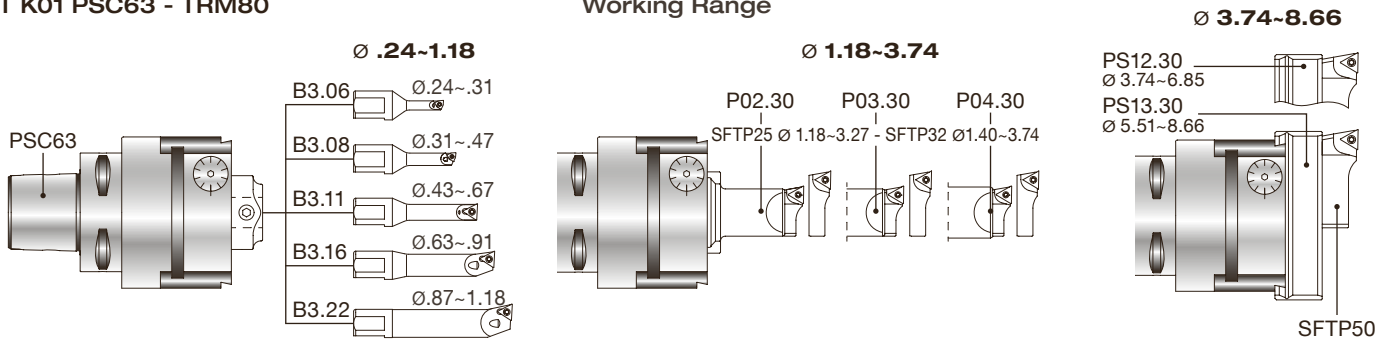

REF.	CODE	TORX T	lb
B1.02	572010502001		0.04
B1.04	572010504001		0.04
B3.06	572010506001	WCGT0201.. TS 21 06	0.08
B3.08	572010508001	WCGT0201.. TS 211 06	0.09
B3.10	572010510001	TPGX0902.. CS 250 T 08	0.11
B3.11	572010511001	TPGX0902.. CS 250 T 08	0.12
B3.12	572010512001	TPGX0902.. CS 250 T 08	0.06
B3.14	572010514001	TPGX0902.. CS 250 T 08	0.15
B3.16	572010516001	TPGX0902.. CS 250 T 08	0.15
B3.18	572010518001	TPGX0902.. CS 250 T 08	0.22
B3.22	572010522001	TPGX0902.. CS 250 T 08	0.22

REF.	CODE	TORX T	lb
B5.06	572010506105	WCGT0201.. TS 21 06	0.17
B5.08	572010508105	WCGT0201.. TS 211 06	0.20
B5.10	572010510105	TPGX0902.. CS 250 T 08	0.22
B5.12	572010512105	TPGX0902.. CS 250 T 08	0.22
B5.14	572010514105	TPGX0902.. CS 250 T 08	0.44
B5.16	572010516105	TPGX0902.. CS 250 T 08	0.3
B8.06	572010506108	WCGT0201.. TS 21 06	0.66
B8.08	572010508108	WCGT0201.. TS 211 06	0.18
B8.10	572010510108	TPGX0902.. CS 250 T 08	0.22
B8.12	572010512108	TPGX0902.. CS 250 T 08	0.44
B8.14	572010514108	TPGX0902.. CS 250 T 08	0.44
B8.16	572010516108	TPGX0902.. CS 250 T 08	0.66

REF.	CODE	TORX T	lb
SFTP25	470500525001	TPGX0902.. CS 250T 08	0.02
SFTP32	470500532001	TPGX0902.. CS 250T 08	0.09
SFTP50	470500550001	TPGX1103.. CS300890T 08	0.18
SFTP51	470500550003	TCMT16T3.. TS 4 15	0.20

REF.	CODE	TORX T	lb
SFCC25	470500525002	CCGT0602.. TS 25 08	0.02
SFCC32	470500532002	CCGT0602.. TS 25 08	0.04
SFCC50	470500550002	CCGT09T3.. TS 4 15	0.18
SFCC51	470500550004	CCMT1204.. TS 5 25	0.20

• For back-facing machining see p.23

TCD' is the turning tools offering made according to the ISO 26623-1 **PSC** standards for Application on MULTI-TASK machines. The **TCD'** line is offered with coolant through channels.

PSC - TU ISO 26623-1

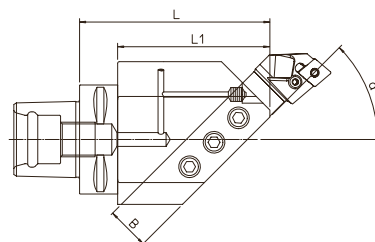
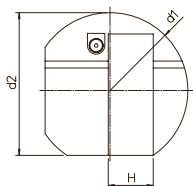

Right hand tool holder shown. A standard Application requires left hand tools with right hand adapters.

PSC	REF.	CODE	L	L1	d1	d2	a°	BxH	lb
50	TCD' PSC50 - TU20.45R	71PSC050T2045R1	3.54	2.76	2.83	2.56	45°	.79x.79	3.97
50	TCD' PSC50 - TU20.45L	71PSC050T2045L1	3.54	2.76	2.83	2.56	45°	.79x.79	3.97
63	TCD' PSC63 - TU25.45R	71PSC063T2545R1	4.33	3.46	3.54	3.25	45°	.98x.98	7.72
63	TCD' PSC63 - TU25.45L	71PSC063T2545L1	4.33	3.46	3.54	3.25	45°	.98x.98	7.72
80	TCD' PSC80 - TU32.45R	71PSC080T3245R1	5.31	4.13	4.53	3.88	45°	1.26x1.26	14.11
80	TCD' PSC80 - TU32.45L	71PSC080T3245L1	5.31	4.13	4.53	3.88	45°	1.26x1.26	14.11

PSC - TU ISO 26623-1

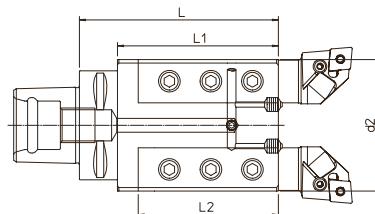
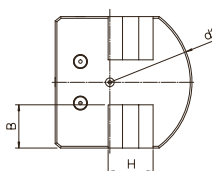

PSC	REF.	CODE	L	L1	L2	d1	d2	BxH	lb
50	TCD' PSC50 - TU20.02	71PSC050T200201	3.94	3.15	2.52	3.15	2.48	.79x.79	5.51
63	TCD' PSC63 - TU25.02	71PSC063T250201	4.53	3.66	3.15	3.74	2.99	.98x.98	8.82
80	TCD' PSC80 - TU32.02	71PSC080T320201	4.92	3.74	3.15	4.53	3.39	1.26x1.26	14.59

PSC - TU ISO 26623-1

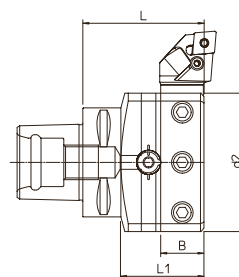
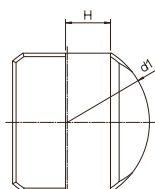

PSC	REF.	CODE	L	L1	d1	d2	BxH	lb
50	TCD' PSC50 - TU20.90	71PSC050T209001	2.36	1.57	3.15	2.52	.79x.79	3.09
63	TCD' PSC63 - TU25.90	71PSC063T259001	2.76	1.89	3.74	3.15	.98x.98	5.73
80	TCD' PSC80 - TU32.90	71PSC080T329001	3.35	2.17	5.24	4.13	1.26x1.26	11.46

PSC - D... ISO 26623-1

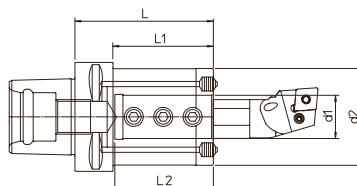

PSC	REF.	CODE	d1H7	d2	L	L1	L2	lb	Reduction bushes on request
50	TCD' PSC50 - D.25x80	71PSC050D250801	.98	2.20	3.15	2.36	2.28	3.09	
63	TCD' PSC63 - D.25x80	71PSC063D250801	.98	2.20	3.15	2.28	2.28	3.75	
63	TCD' PSC63 - D.40x125	71PSC063D401201	1.57	3.15	4.92	4.06	3.35	8.60	
80	TCD' PSC80 - D.25x85	71PSC080D250801	.98	2.20	85	2.17	2.28	5.73	
63	TCD' PSC80 - D.40x125	71PSC080D401201	1.57	3.15	4.92	3.74	3.35	10.14	

On request supplied with coolant tube **PSC**. See p.57



BHT 250 - 500 - 750

CROSS BARS

ROUGHING

FINISHING - TURNING

.00008 μm

**COUPLING
HT[®]**

**COUPLING
HT[®]**

The new **BHT** boring system is characterized by the new **HT** standard base connection which ensures perfect coupling and high resistance to torsion.

The **BHT** bars cover a working range from $\varnothing 9.84$ to $\varnothing 39.37$ mm, both in roughing and finishing.

The wide range of accessories includes adjustable ISO-CA roughing cartridges and a TRM 63 STANDARD micrometric finishing head, capable of carrying out boring, chamfering and back-boring operations.

The FINISHING configuration system can be balanced with the addition of counterweights.

ROUGHING

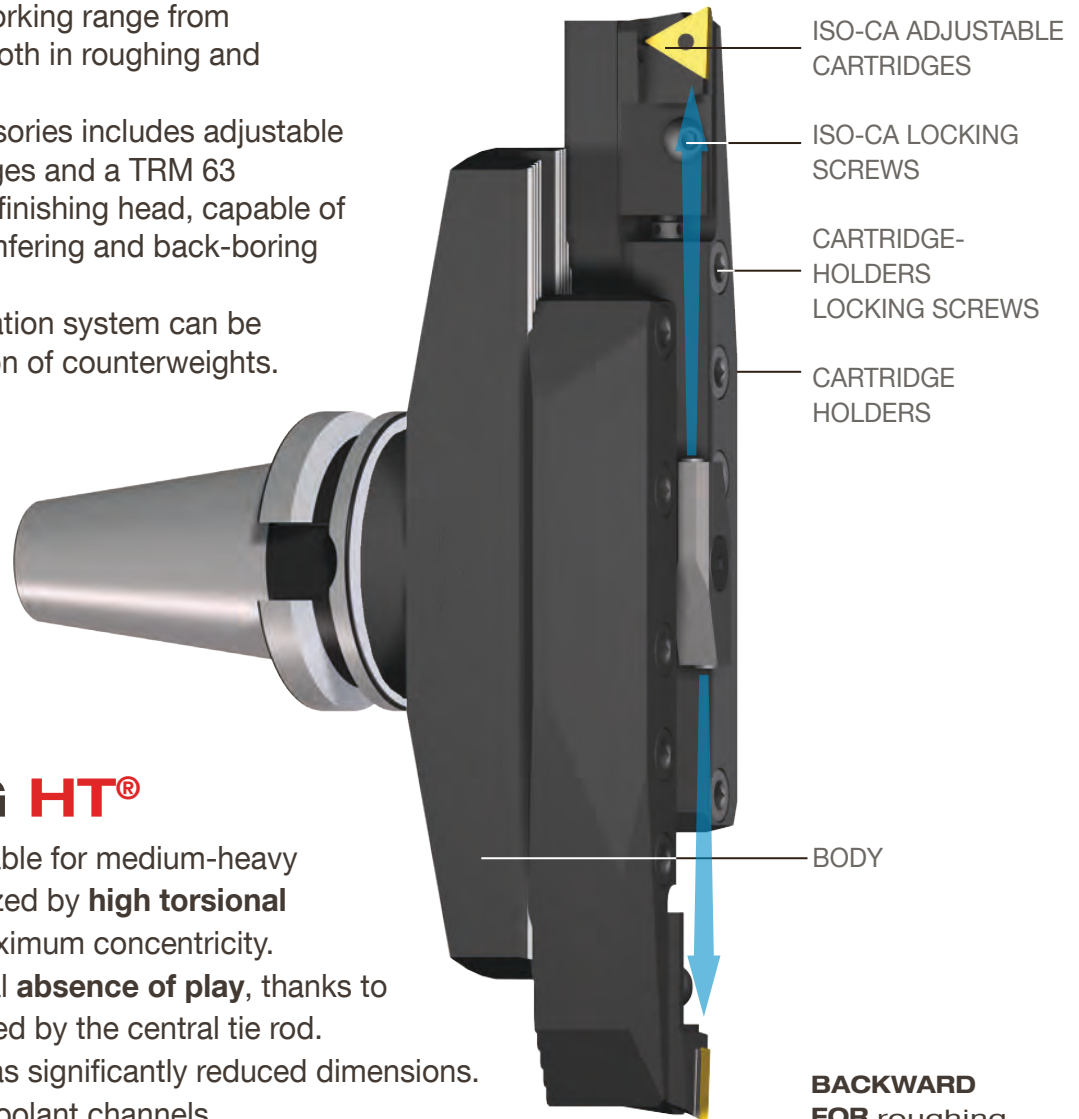

ISO-CA ADJUSTABLE CARTRIDGES

ISO-CA LOCKING SCREWS

CARTRIDGE-HOLDERS LOCKING SCREWS

CARTRIDGE HOLDERS

BODY

BACKWARD
FOR roughing operations **USE**
TS 63/63
+SSQC 63
see page 24

COUPLING HT®

1. The HT system is suitable for medium-heavy machining, characterized by **high torsional components** with maximum concentricity.
2. The guarantee the total **absence of play**, thanks to the pulling force exerted by the central tie rod.
3. The new HT system has significantly reduced dimensions.
4. It facilitates the axial coolant channels.
5. The arbors are made with hardness HRc 55-60.
6. The tool body is produced with hardness HRc 45-50.

POLIGONAL SHANK HT COUPLING, CONTACT AND DRIVING SURFACE

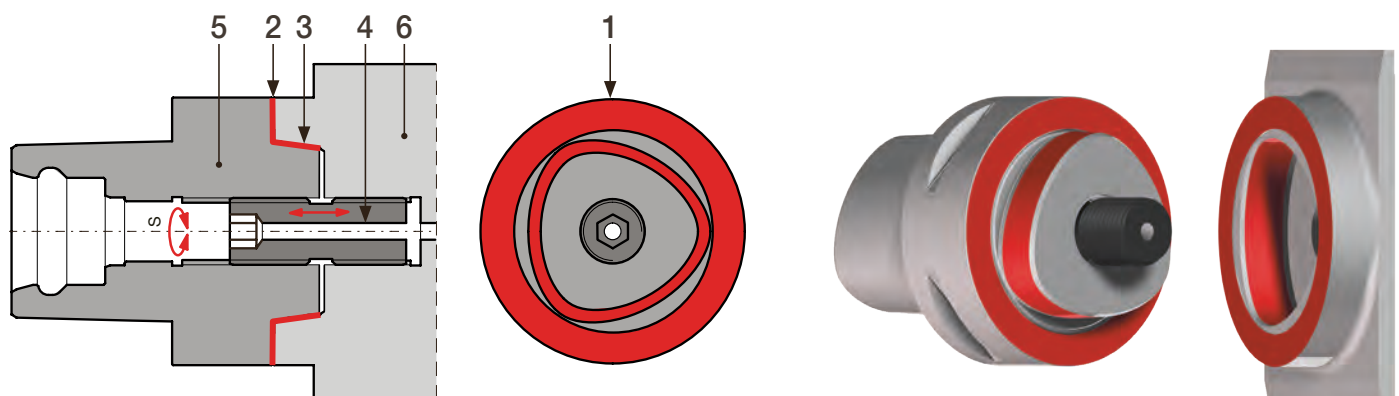

HT	⬡ S	N-m
8	8	442.54-531.04

FINISHING - TURNING

.00008 μm

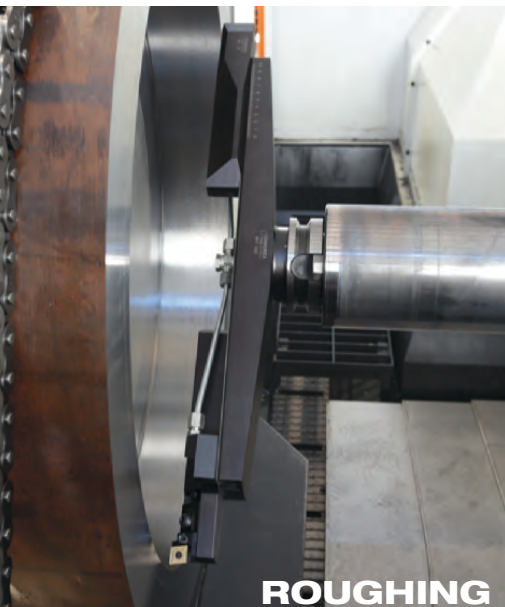
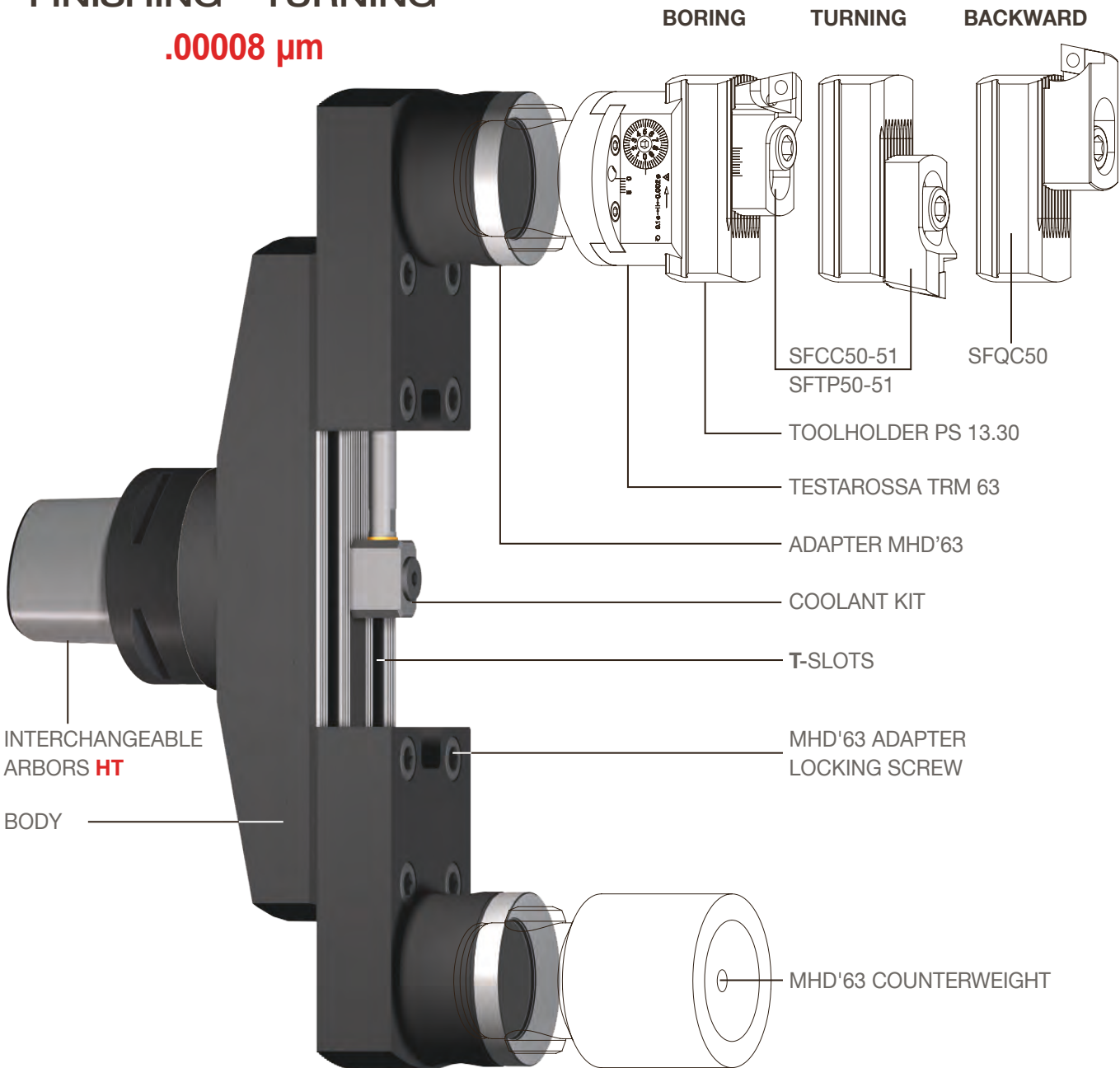

ARBORS **HT** PATENTED

BHT 250 \varnothing 9.84 ~ 19.69



HT

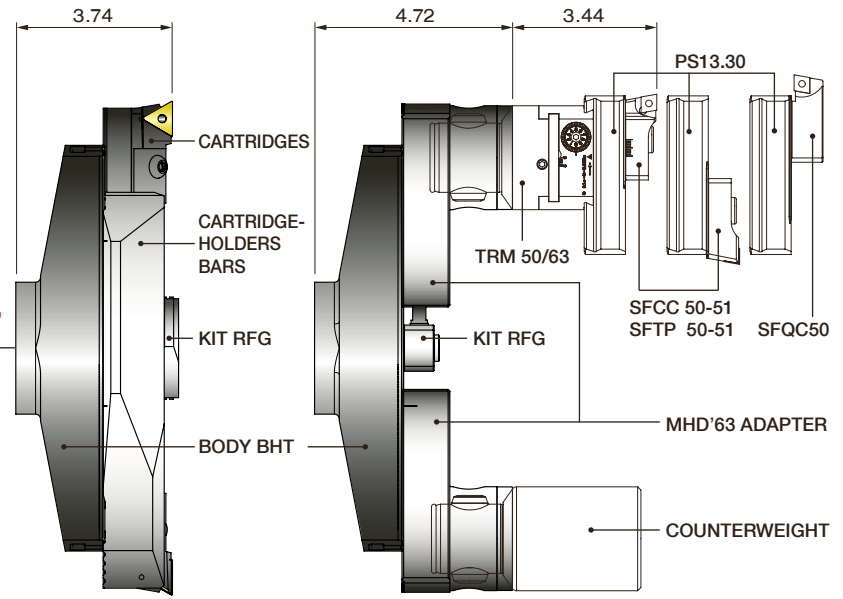

	REF.	CODE	lb
DIN 69871-AD50	HT8 .36.5	41HT08025000	7.50
MAS403BT-AD50	HT8 .38.5	41HT08035000	8.16
PSC 80	HT8 .30	41HT08018000	4.41
HSK 100	HT8 .76.5	41HT08041000	8.82
CAT 50 UNC	HT8 .50.5	41HT08055000	8.60
MHD' 80	HT8	655108000080	4.41

COMPONENTS AND ACCESSORIES

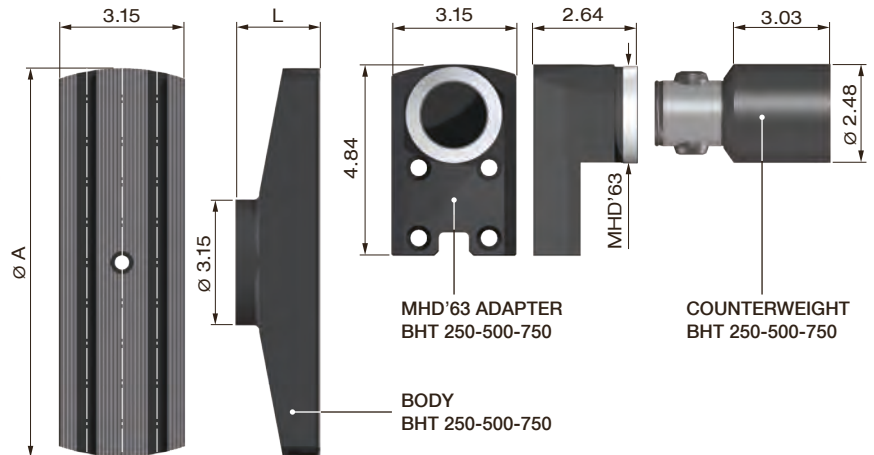

ISO-CA CARTRIDGE HOLDERS

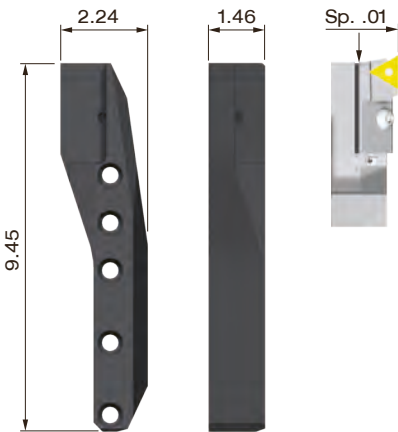

ISO-CA CARTRIDGE HOLDERS BHT 250-500-750

CODE	382090024000	lb	5.51
------	--------------	----	------

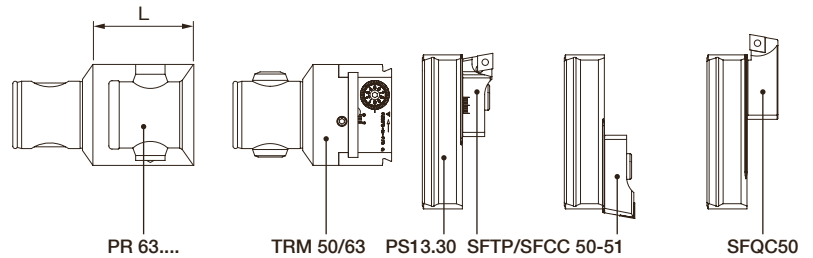

CARTRIDGES 20CA ISO 5611

PTGNL20CA-22	SCGCL20CA-12
CODE 483010201001	CODE 483010201003
TNM2204	CCM1204
PCGNL20CA-16	PSRNL20CA-15
CODE 483010201002	CODE 483010201004
CNM1606	SNM1506

REF.	CODE	\varnothing	A	L	lb
BODY BHT 250	435508882460	9.84~16.69	9.69	2.13	8.82
BODY BHT 500	435508882960	19.69~29.53	19.53	2.13	15.87
BODY BHT 750	435508887460	29.53~39.37	29.37	2.36	28.66
MHD'63 ADAPTER BHT 250-500-750	382090006301				5.51
COUNTERWEIGHT BHT 250-500-750	392011006300				5.29
TRM 50/63	BHT 250-500-750	455005000631			2.43
PS 13.30	BHT 250-500-750	433030261400			1.54
PR 63.63	BHT 250-500-750	656906300630		2.48	3.09
PR 63.100	BHT 250-500-750	656906301000		100	4.85
PR 63.125	BHT 250-500-750	656906301250		125	6.39

BHT suitable for bigger diameters ON REQUEST

BHT 500 \varnothing 19.69 ~ 29.53

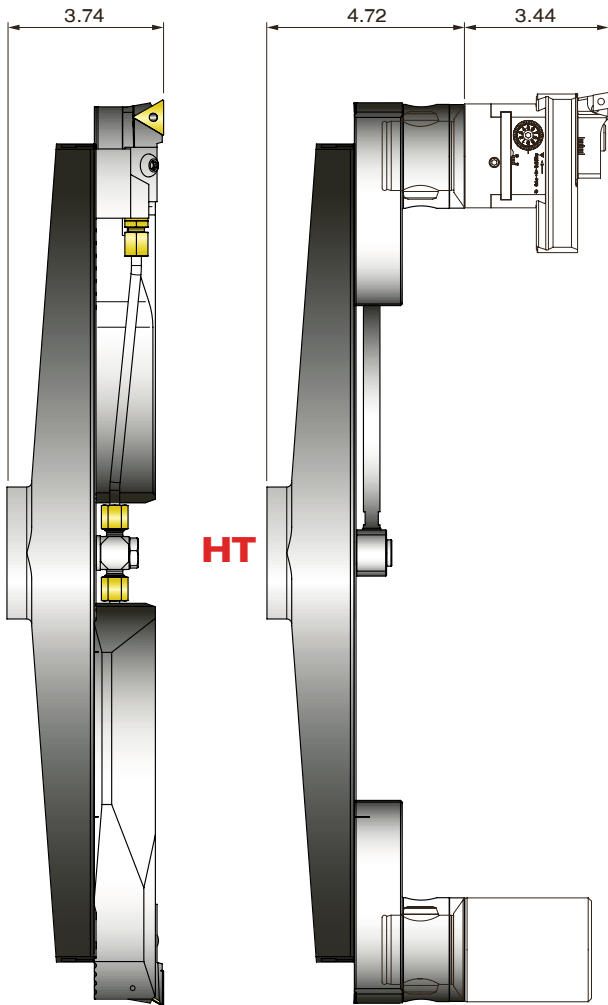

BHT 750 \varnothing 29.53 ~ 39.37

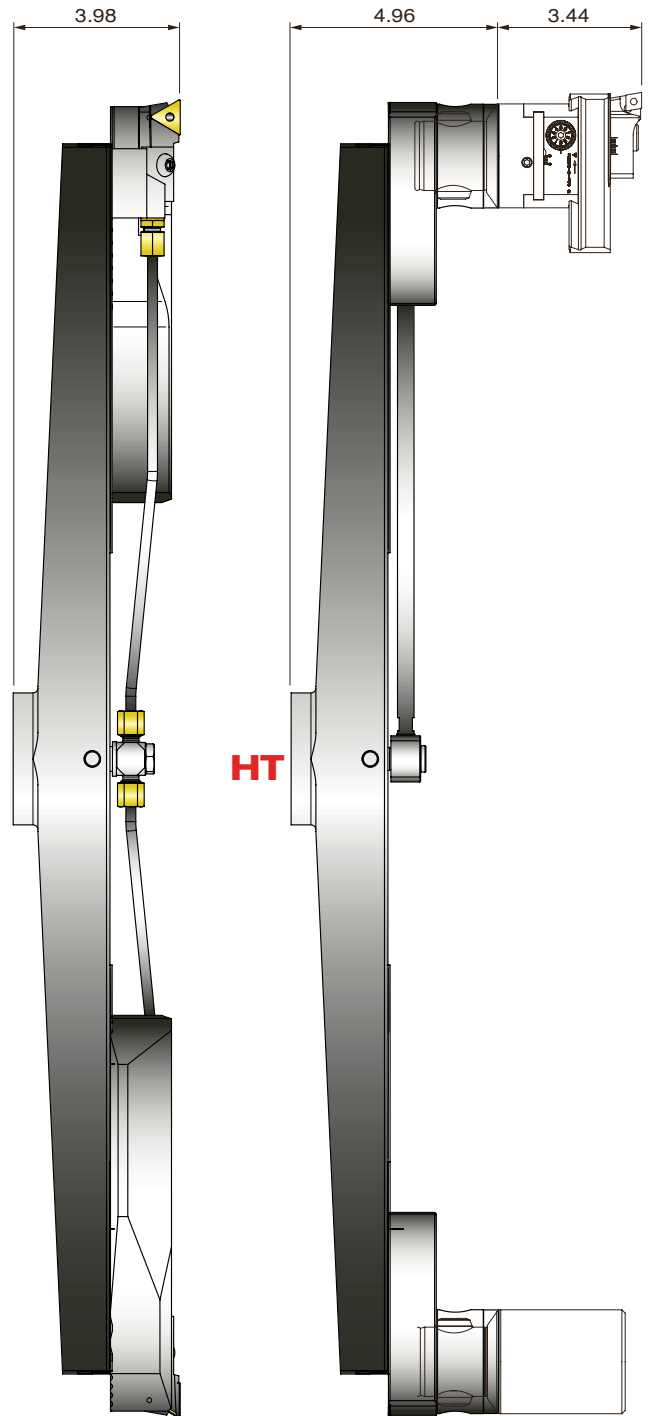

COOLANT KIT

ROUGHING



KIT RFG BHT 250 SG
CODE 382090025000

FINISHING



KIT RFG BHT 250 FN
CODE 382090025001



KIT RFG BHT 500 SG
CODE 382090050003



KIT RFG BHT 500 FN
CODE 382090050004



KIT RFG BHT 750 SG
CODE 382090075000



KIT RFG BHT 750 FN
CODE 382090075001

BIT-HOLDERS SF..



SFTP50
SFTP51



SFCC50
SFCC51



SFQC50

REF.	CODE	△	⊗	♻️	TORX	lb
SFTP50	470500550001	TPGX 1103..		CS300890T	08	0.18
SFTP51	470500550003	TCMT 16T3..	TS 4		15	0.20
SFCC50	470500550002	CCGT 09T3..	TS 4		15	0.18
SFCC51	470500550004	CCMT 1204..	TS 5		25	0.20
SFQC 50	470500550062	CCMT 09T3..	TS 4		15	0.22

INSERTS

WCGT ○○○○○○L

FINISHING

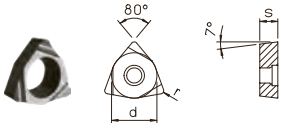

REF.	CODE	d	s	r	⌀	🔑
WCGT 020102L DC 100	CERMET WCGT020102LC100	3.97	1.59	0.2	TS 21* - TS 211*	TORX T06
WCGT 020102L DC 100T	COATED CERMET WCGT020102LC10T	3.97	1.59	0.2	TS 21* - TS 211*	TORX T06
WCGT 020102L DK 100	CARBIDE WCGT020102LK100	3.97	1.59	0.2	TS 21* - TS 211*	TORX T06
WCGT 020102L DP 300	CARBIDE WCGT020102LP300	3.97	1.59	0.2	TS 21* - TS 211*	TORX T06
WCGT 020104L DC 100	CERMET WCGT020104LC100	3.97	1.59	0.4	TS 21* - TS 211*	TORX T06
WCGT 020104L DC 100T	COATED CERMET WCGT020104LC10T	3.97	1.59	0.4	TS 21* - TS 211*	TORX T06
WCGT 020104L DK 100	CARBIDE WCGT020104LK100	3.97	1.59	0.4	TS 21* - TS 211*	TORX T06
WCGT 020104L DP 300	CARBIDE WCGT020104LP300	3.97	1.59	0.4	TS 21* - TS 211*	TORX T06

* TS21 : B...06 / * TS211 : B...08

CCGT ○○○○○○L

FINISHING

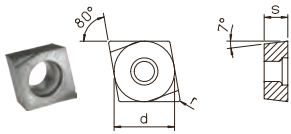

REF.	CODE	d	s	r	⌀	🔑
CCGT 060200L DC 100	CERMET CCGT060200LC100	6.35	2.38	0	TS 25	TORX T08
CCGT 060200L DC 100T	COATED CERMET CCGT060200LC10T	6.35	2.38	0	TS 25	TORX T08
CCGT 060200L DK 100	CARBIDE CCGT060200LK100	6.35	2.38	0	TS 25	TORX T08
CCGT 060200L DP 300	CARBIDE CCGT060200LP300	6.35	2.38	0	TS 25	TORX T08
CCGT 060202L DC 100	CERMET CCGT060202LC100	6.35	2.38	0.2	TS 25	TORX T08
CCGT 060202L DC 100T	COATED CERMET CCGT060202LC10T	6.35	2.38	0.2	TS 25	TORX T08
CCGT 060202L DK 100	CARBIDE CCGT060202LK100	6.35	2.38	0.2	TS 25	TORX T08
CCGT 060202L DP 300	CARBIDE CCGT060202LP300	6.35	2.38	0.2	TS 25	TORX T08
CCGT 060204L DC 100	CERMET CCGT060204LC100	6.35	2.38	0.4	TS 25	TORX T08
CCGT 060204L DC 100T	COATED CERMET CCGT060204LC10T	6.35	2.38	0.4	TS 25	TORX T08
CCGT 060204L DK 100	CARBIDE CCGT060204LK100	6.35	2.38	0.4	TS 25	TORX T08
CCGT 060204L DP 300	CARBIDE CCGT060204LP300	6.35	2.38	0.4	TS 25	TORX T08
CCGT 09T302L DC 100	CERMET CCGT09T302LC100	9.525	3.97	0.2	TS 4	TORX T15
CCGT 09T302L DC 100T	COATED CERMET CCGT09T302LC10T	9.525	3.97	0.2	TS 4	TORX T15
CCGT 09T302L DK 100	CARBIDE CCGT09T302LK100	9.525	3.97	0.2	TS 4	TORX T15
CCGT 09T302L DP 300	CARBIDE CCGT09T302LP300	9.525	3.97	0.2	TS 4	TORX T15
CCGT 09T304L DC 100	CERMET CCGT09T304LC100	9.525	3.97	0.4	TS 4	TORX T15
CCGT 09T304L DC 100T	COATED CERMET CCGT09T304LC10T	9.525	3.97	0.4	TS 4	TORX T15
CCGT 09T304L DK 100	CARBIDE CCGT09T304LK100	9.525	3.97	0.4	TS 4	TORX T15
CCGT 09T304L DP 300	CARBIDE CCGT09T304LP300	9.525	3.97	0.4	TS 4	TORX T15

TPGX ○○○○○○L

FINISHING

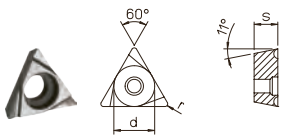

REF.	CODE	d	s	r	⌀	🔑
TPGX 090200L DC 100	CERMET TPGX090200LC100	5.56	2.38	0	CS250T	TORX T08
TPGX 090200L DC 100T	COATED CERMET TPGX090200LC10T	5.56	2.38	0	CS250T	TORX T08
TPGX 090200L DK 100	CARBIDE TPGX090200LK100	5.56	2.38	0	CS250T	TORX T08
TPGX 090200L DP 300	CARBIDE TPGX090200LP300	5.56	2.38	0	CS250T	TORX T08
TPGX 090202L DC 100	CERMET TPGX090202LC100	5.56	2.38	0.2	CS250T	TORX T08
TPGX 090202L DC 100T	COATED CERMET TPGX090202LC10T	5.56	2.38	0.2	CS250T	TORX T08
TPGX 090202L DK 100	CARBIDE TPGX090202LK100	5.56	2.38	0.2	CS250T	TORX T08
TPGX 090202L DP 300	CARBIDE TPGX090202LP300	5.56	2.38	0.2	CS250T	TORX T08
TPGX 090204L DC 100	CERMET TPGX090204LC100	5.56	2.38	0.4	CS250T	TORX T08
TPGX 090204L DC 100T	COATED CERMET TPGX090204LC10T	5.56	2.38	0.4	CS250T	TORX T08
TPGX 090204L DK 100	CARBIDE TPGX090204LK100	5.56	2.38	0.4	CS250T	TORX T08
TPGX 090204L DP 300	CARBIDE TPGX090204LP300	5.56	2.38	0.4	CS250T	TORX T08
TPGX 110300L DC 100	CERMET TPGX110300LC100	6.35	3.18	0	CS300890T	TORX T08
TPGX 110300L DC 100T	COATED CERMET TPGX110300LC10T	6.35	3.18	0	CS300890T	TORX T08
TPGX 110300L DK 100	CARBIDE TPGX110300LK100	6.35	3.18	0	CS300890T	TORX T08
TPGX 110300L DP 300	CARBIDE TPGX110300LP300	6.35	3.18	0	CS300890T	TORX T08
TPGX 110302L DC 100	CERMET TPGX110302LC100	6.35	3.18	0.2	CS300890T	TORX T08
TPGX 110302L DC 100T	COATED CERMET TPGX110302LC10T	6.35	3.18	0.2	CS300890T	TORX T08
TPGX 110302L DK 100	CARBIDE TPGX110302LK100	6.35	3.18	0.2	CS300890T	TORX T08
TPGX 110302L DP 300	CARBIDE TPGX110302LP300	6.35	3.18	0.2	CS300890T	TORX T08
TPGX 110304L DC 100	CERMET TPGX110304LC100	6.35	3.18	0.4	CS300890T	TORX T08
TPGX 110304L DC 100T	COATED CERMET TPGX110304LC10T	6.35	3.18	0.4	CS300890T	TORX T08
TPGX 110304L DK 100	CARBIDE TPGX110304LK100	6.35	3.18	0.4	CS300890T	TORX T08
TPGX 110304L DP 300	CARBIDE TPGX110304LP300	6.35	3.18	0.4	CS300890T	TORX T08

INSERT CLAMPING SCREWS

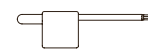
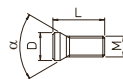

TORX WRENCH

REF.	⌀	CODE	M	L	D	α	N·m	REF.	🔑	CODE
TS 21		494010002034	M 2x0.4	3.7	2.7	60°	0,5	TORX T06		101500900600
TS 211		494010002040	M 2x0.4	4	2.7	60°	0,5	TORX T06		101500900600
CS 250 T		494010002565	M 2.5x0.45	6	3.7	90°	1,0	TORX T08		101500900800
CS 300890 T		494010003008	M 3x0.5	8	4.1	90°	1,0	TORX T08		101500900800
TS 25		494010002555	M 2.5x0.45	5.7	3.45	60°	1,0	TORX T08		101500900800
TS 4		494010004008	M 4x0.7	10	5.5	60°	3,0	TORX T15		101500901500
TS 5		494010005009	M 5x0.8	11.5	7	60°	7,5	TORX T25		101500902500

TPGX ○○○○○○ FINISHING

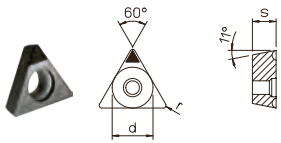

REF.	CODE	d	s	r		
TPGX 090202 D20 MDC	TPGX090202MDC20	5.56	2.38	0.2	CS250T	TORX T08
TPGX 090204 D20 MDC	TPGX090204MDC20	5.56	2.38	0.4	CS250T	TORX T08
TPGX 110302 D20 MDC	TPGX110302MDC20	6.35	3.18	0.2	CS300890T	TORX T08
TPGX 110304 D20 MDC	TPGX110304MDC20	6.35	3.18	0.4	CS300890T	TORX T08
TPGX 090202 D20 CBN	TPGX090202CBN20	5.56	2.38	0.2	CS250T	TORX T08
TPGX 090202 D25 CBN	TPGX090202CBN25	5.56	2.38	0.2	CS250T	TORX T08
TPGX 090204 D20 CBN	TPGX090204CBN20	5.56	2.38	0.4	CS250T	TORX T08
TPGX 090204 D25 CBN	TPGX090204CBN25	5.56	2.38	0.4	CS250T	TORX T08
TPGX 110302 D25 CBN	TPGX110302CBN25	6.35	3.18	0.2	CS300890T	TORX T08
TPGX 110304 D20 CBN	TPGX110304CBN20	6.35	3.18	0.4	CS300890T	TORX T08
TPGX 110304 D25 CBN	TPGX110304CBN25	6.35	3.18	0.4	CS300890T	TORX T08

CCMT ○○○○○○ ROUGHING

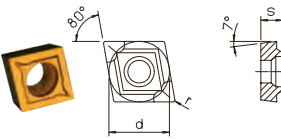

REF.	CODE	d	s	r		
CCMT 060202 DP 100R	CCMT060202P100R	6.35	2.38	0.2	TS 25	TORX T08
CCMT 060202 DP 300	CCMT060202P300	6.35	2.38	0.2	TS 25	TORX T08
CCMT 060204 DP 100R	CCMT060204P100R	6.35	2.38	0.4	TS 25	TORX T08
CCMT 060204 DP 300	CCMT060204P300	6.35	2.38	0.4	TS 25	TORX T08
CCMT 09T304 DP 100R	CCMT09T304P100R	9.525	3.97	0.4	TS 4	TORX T15
CCMT 09T304 DP 300	CCMT09T304P300	9.525	3.97	0.4	TS 4	TORX T15
CCMT 09T308 DP 100R	CCMT09T308P100R	9.525	3.97	0.8	TS 4	TORX T15
CCMT 09T308 DP 300	CCMT09T308P300	9.525	3.97	0.8	TS 4	TORX T15
CCMT 120404 DP 100R	CCMT120404P100R	12.7	4.76	0.4	TS 5	TORX T25
CCMT 120404 DP 300	CCMT120404P300	12.7	4.76	0.4	TS 5	TORX T25
CCMT 120408 DP 100R	CCMT120408P100R	12.7	4.76	0.8	TS 5	TORX T25
CCMT 120408 DP 300	CCMT120408P300	12.7	4.76	0.8	TS 5	TORX T25

BORING GRADE

ISO	CARBIDE	CERMET	COATED CERMET	CVD COATED CARBIDE
P01				
P10		DC100	DC100T	DP100R
P20				
P30	DP300			
P40				
K01				
K10	DK100	DC100	DC100T	DP100R
K20				
K30	DP300			

DP300	Roughing and finishing. Low carbon steel - stainless steels
DK100	Roughing and finishing. Aluminium alloy cast iron
DP100R	Roughing. Steels, alloy steels and cast iron
DC100	Finishing. Alloy steels and cast iron
DC100T	Finishing. Alloy steels, stainless steels and cast iron
D20MDC	Finishing. Aluminium alloys, non-ferrous materials and non-metals
D20CBN	Finishing. High hardness steels (over 50 HRC) (it may replace the grinding)
D25CBN	Finishing. High hardness steels (over 50 HRC) and interrupted cutting (it may replace the grinding)

TECHNICAL DATA CUTTING DATA

RECOMMENDED CUTTING CONDITIONS FOR ROUGHING OPERATIONS WITH DOUBLE-BIT HEADS TS

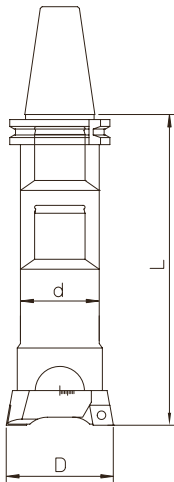

material	boring bar dimensions	working conditions	cutting speed Vc = sfmm/min. diameter			feed f= ipr (twin cutters) insert radius		
			D < 1.50	D=1.50-4.72	D > 4.72	R = .008	R = .016	R = .31
carbon steel HB ≤ 200	L / d = 2.5	good	393 - 590	460 - 655	525 - 820		.008 - .016	.012 - .020
	L / d = 4	normal	328 - 525	393 - 590	460 - 655		.008 - .016	.012 - .020
	L / d = 6.3	difficult	230 - 328	230 - 328	230 - 328	.006 - .012	.008 - .016	
carbon steel HB > 200	L / d = 2.5	good	328 - 525	393 - 590	460 - 655		.008 - .016	.012 - .020
	L / d = 4	normal	260 - 460	328 - 525	393 - 590		.008 - .016	.012 - .020
	L / d = 6.3	difficult	196 - 295	230 - 328	230 - 328	.006 - .012	.008 - .016	
stainless steel AISI 304 - 316	L / d = 2.5	good	260 - 360	295 - 393	328 - 460		.008 - .016	.012 - .020
	L / d = 4	normal	230 - 328	260 - 360	295 - 393		.008 - .016	.012 - .020
	L / d = 6.3	difficult	196 - 295	196 - 295	196 - 295	.006 - .012	.008 - .016	
cast iron	L / d = 2.5	good	295 - 393	328 - 460	393 - 525		.008 - .016	.012 - .020
	L / d = 4	normal	230 - 328	295 - 393	328 - 460		.008 - .016	.012 - .020
	L / d = 6.3	difficult	196 - 295	196 - 295	196 - 295	.006 - .012	.008 - .016	
aluminium	L / d = 2.5	good	525 - 820	655 - 984	820 - 1148		.012 - .020	.016 - .024
	L / d = 4	normal	460 - 655	525 - 820	655 - 984		.012 - .020	.016 - .024
	L / d = 6.3	difficult	328 - 492	328 - 492	328 - 492	.008 - .016	.012 - .020	

cutting depth ap = mm	working range Ø = mm	max. cutting depth	
		steel	cast iron, aluminium
	.71 - 1.10	.06 - .07	.07 - .09
	1.10 - 1.97	.07 - .12	.09 - .14
	1.97 - 2.67	.12 - .15	.14 - .19
	1.97 - 2.67	.15 - .19	.19 - .27
	7.87 - 19.68	.19 - .23	.23 - .31

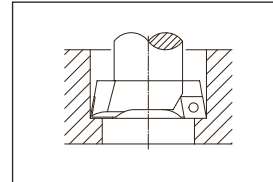

Twin cutters at the same cutting diameter

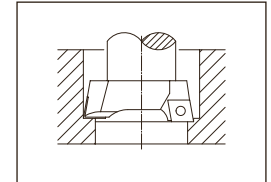

Twin cutters at different cutting diameters

It's advisable to start with B hole ≥ the boring bar diameter d.

ATTENTION: For boring operations at different diameters, reduce to a half the feed indicated on the above table.

RECOMMENDED CUTTING CONDITIONS FOR BORING OPERATIONS WITH TESTAROSSA TRM / TR-E

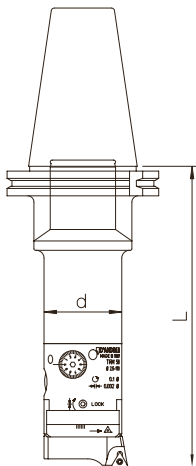

material	boring bar dimensions	working conditions	cutting speed Vc = sfmm/min.	feed f= ipr insert radius			quality insert	cutting depth
				R = .000	R = .008	R = .016		
carbon steel HB ≤ 200	L / d = 2.5	good	655 - 984		.002 - .003	.003 - .004	DC100 DP300	
	L / d = 4	normal	525 - 820		.002 - .003	.003 - .004		
	L / d = 6.3	difficult	230 - 328	.002 - 0.03	.002 - .003			
carbon steel HB > 200	L / d = 2.5	good	525 - 820		.002 - .003	.003 - .004	DC100	
	L / d = 4	normal	492 - 655		.002 - .003	.003 - .004		
	L / d = 6.3	difficult	230 - 328	.002 - 0.03	.002 - .003			
stainless steel AISI 304 - 316	L / d = 2.5	good	393 - 525		.002 - .003	.003 - .004	DP300	
	L / d = 4	normal	328 - 460		.002 - .003	.003 - .004		
	L / d = 6.3	difficult	230 - 328	.002 - 0.03	.002 - .003			
cast iron	L / d = 2.5	good	393 - 525		.002 - .003	.003 - .004	DK100 DP100	
	L / d = 4	normal	328 - 460		.002 - .003	.003 - .004		
	L / d = 6.3	difficult	230 - 328	.002 - 0.03	.002 - .003			
aluminium	L / d = 2.5	good	984 - 1312		.002 - .003	.003 - .004	DK100	
	L / d = 4	normal	820 - 1148		.002 - .003	.003 - .004		
	L / d = 6.3	difficult	260 - 492	.002 - 0.03	.002 - .003			
steel HB > 200	L / d = 2.5	good	260 - 328		.002 - .003	.002 - 0.03	D20CBN	
	L / d = 4	normal	260 - 328		.002 - .003	.002 - 0.03		

CALCULATION FORMULAS FOR BORING

Vc cutting speed (sfm)
 D diameter of workpiece (inch)
 n number of revolutions / min' (rpm)
 Vf feed rate (ipm)
 fn feed (ipr)
 pi 3.14

$$Vc = \frac{\pi \cdot D \cdot n}{12}$$

$$n = \frac{Vc \cdot 12}{\pi \cdot D}$$

$$Vf = n \cdot fn$$

RECOMMENDED CUTTING CONDITIONS FOR ROUGHING OPERATIONS BHT 250-500-750

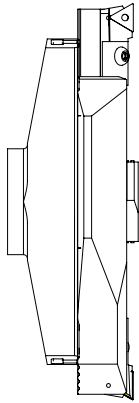

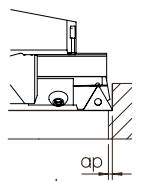
material	boring bar dimensions	working conditions	cutting speed Vc= sfmm/min.	feed f= ipr (twin cutters) insert radius		cutting depth		
				R = .008	R = .016	steel	cast iron aluminium	
carbon steel HB ≤ 200	L / d = 2.5	good	525 - 820	.008 - .016	.012 - .020		.06 - .31 mm	
	L / d = 4	normal	460 - 655	.008 - .016	.012 - .020			
carbon steel HB > 200	L / d = 2.5	good	460 - 655	.008 - .016	.012 - .020			
	L / d = 4	normal	393 - 590	.008 - .016	.012 - .020			
stainless steel AISI 304 - 316	L / d = 2.5	good	328 - 460	.008 - .016	.012 - .020			
	L / d = 4	normal	262 - 393	.008 - .016	.012 - .020			
cast iron ductile cast iron	L / d = 2.5	good	393 - 525	.008 - .016	.012 - .020			
	L / d = 4	normal	328 - 460	.008 - .016	.012 - .020			
aluminium	L / d = 2.5	good	820 - 1148	.012 - .020	.016 - .024			.06 - .39 mm
	L / d = 4	normal	655 - 984	.012 - .020	.016 - .024			

RECOMMENDED CUTTING CONDITIONS FOR FINISHING OPERATIONS CON BHT 250-500-750

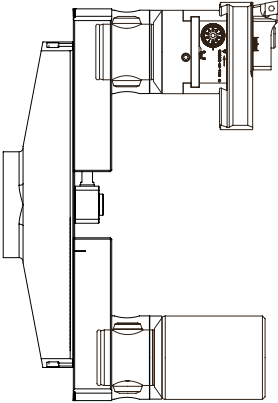

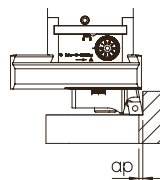

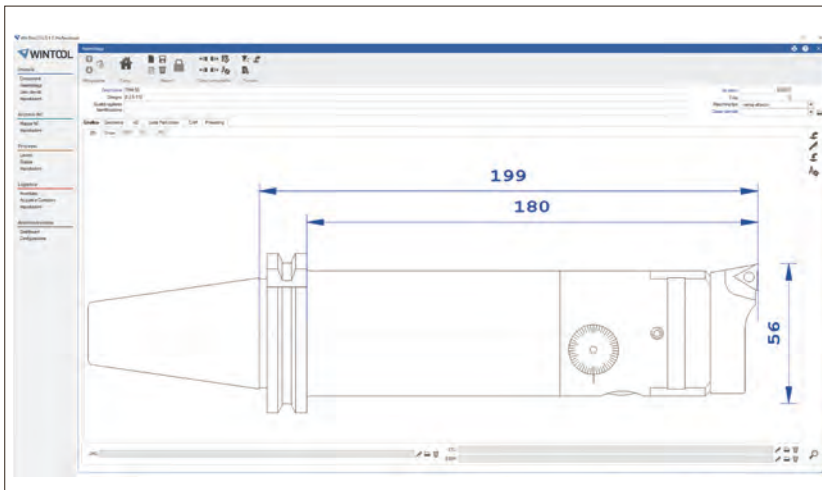

material	boring bar dimensions	working conditions	cutting speed Vc= sfmm/min.	feed f= ipr insert radius		cutting depth	quality insert				
				R = .008	R = .016						
carbon steel HB ≤ 200	L / d = 2.5	good	655 - 984	.002 - .003	.003 - .004		DC100 DP300				
	L / d = 4	normal	492 - 820	.002 - .003	.003 - .004						
carbon steel HB > 200	L / d = 2.5	good	525 - 820	.002 - .003	.003 - .004		.006 - .01 mm	DC100 DC100T			
	L / d = 4	normal	460 - 655	.002 - .003	.003 - .004						
stainless steel AISI 304 - 316	L / d = 2.5	good	295 - 460	.002 - .003	.003 - .004			DK100 DC100			
	L / d = 4	normal	262 - 393	.002 - .003	.003 - .004						
cast iron ductile cast iron	L / d = 2.5	good	393 - 590	.002 - .003	.003 - .004				DK100		
	L / d = 4	normal	328 - 140	.002 - .003	.003 - .004						
aluminium	L / d = 2.5	good	250 - 460	.002 - .003	.003 - .004					D20CBN	
	L / d = 4	normal	655 - 1148	.002 - .003	.003 - .004						
Hardened steel	L / d = 2.5	good	196 - 328	.002 - .003	.003 - .004						
	L / d = 4	normal	196 - 328	.002 - .003	.003 - .004						

WINTOOL

It allows to be graphically constructed in a short period of time, showing the complete composition of the Modulhard'Andrea tools, including dimensions, weight and the list of components.



Scheda Utensile		WINTOOL	
*dettagli utensili inclusi. Condizioni di taglio.			
600038	TRM 50 Ø 2.5-110	Macchine tipo	senza attacco
		diametro parte pezzo Lunghezza taglio Raggio Arco maglietta Lunghezza Lung. collisione (L3) Dia. collisione Lunghezza di taglio Fianco angolo Peso Prezzo	96 0 0 0 199 0 0 0 0 1.08 0
Immissione: 21/11/2023 Modificato: 21/11/2023 RC:Stato Utente: Admin			
Descrizione / Tipo			
1 DIN69871-AD40 MH050.120 MH050		No. del Part / No EDV / Codice prodotto / Località a magazzino	
		416501204020	
1 TRM 50 Ø 2.5-110		455005000500	
1 SFTF 50 TPGX 1103 - L Ø 54-500		47050050001	

HSK-A

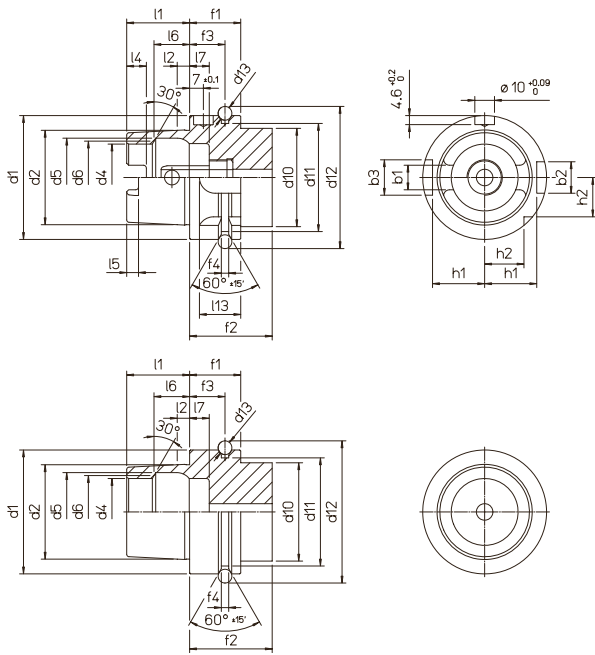

HSK	32	40	50	63	80	100
b1 $+0.04$ -0.04	.28	8.05	10.54	12.54	16.04	20.02
b2 H10	7	9	12	16	18	20
b3 H10	9	11	14	18	20	22
d1 h10	32	40	50	63	80	100
d2	24.007	30.007	38.009	48.010	60.012	75.013
d4 H10	17	21	26	34	42	53
d5 H11	20.5	25.5	32	40	50	63
d6	19	23	29	37	46	58
d10 max.	26	34	42	53	68	88
d11 0 -0.1	26.5	34.8	43	55	70	92
d12 0 -0.1	37	45	59.3	72.3	88.8	109.75
d13	4		7			
f1 0 -0.1	20		26		29	
f2 min.	35		42		45	
f3 ± 0.1	16		18		20	
f4 $+0.15$ 0	2		3.75			
h1 0 -0.2	13	17	21	26.5	34	44
h2 0 -0.3	9.5	12	15.5	20	25	31.5
l1 0 -0.2	16	20	25	32	40	50
l2	3.2	4	5	6.3	8	10
l4 $+0.2$ 0	5	6	7.5	10	12	15
l5 $+0.2$ 0	3	3.5	4.5	6	8	10
l6 JS10	8.92	11.42	14.13	18.13	22.85	28.56
l7 0 -0.1	8		10	10	12.5	12.5
l13	12		19	21	22	24

DIN 69871 A (ISO 7388-1)

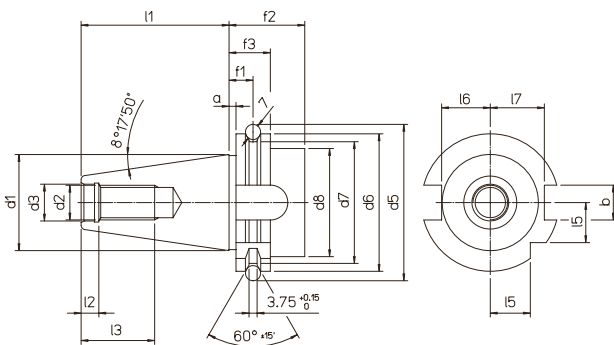

ISO	30	40	45	50	60
a ± 0.1	3.2				
b $+0.5/0$	16.1		19.3	25.7	
d1	31.75	44.45	57.15	69.85	107.95
d2 6H	M12	M16	M20	M24	M30
d3 H7	13	17	21	25	32
d5 ± 0.05	59.3	72.3	91.35	107.25	164.75
d6 $0/-0.1$	50	63.55	82.55	97.50	155
d7 $0/-0.5$	44.3	56.25	75.25	91.25	147.70
d8 max.	45	50	63	80	130
f1 ± 0.1	11.1				
f2 min.	35				38
f3 $0/-0.1$	19.1				
l1 $0/-0.3$	47.8	68.4	82.7	101.75	161.90
l2 $+0.5/0$	5.5	8.2	10	11.5	14
l3 min.	24	32	40	47	59
l5 $0/-0.3$	15	18.5	24	30	49
l6 $0/-0.3$	16.4	22.8	29.1	35.5	54.5
l7 $0/-0.3$	19	25	31.3	37.7	59.3

MAS 403 BT A

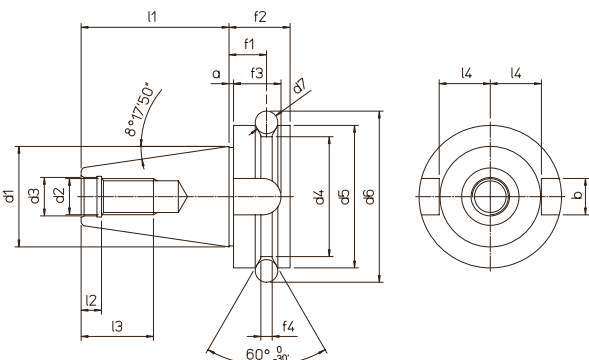

ISO	30	35	40	45	50	60
a ± 0.4	2			3		
b $+0.2/0$	16.1		19.3	25.7	25.7	
d1	31.75	38.10	44.45	57.15	69.85	107.95
d2 6H	M 12		M 16	M 20	M 24	M 30
d3 H8	12.5		17	21	25	31
d4 $0/-0.5$	38	43	53	73	85	135
d5 h8	46	53	63	85	100	155
d6 ± 0.05	56.03	65.68	75.56	100.09	118.89	180.22
d7	8	10		12	15	20
f1 ± 0.1	13.6	14.6	16.6	21.2	23.2	28.2
f2	22	24	27	33	38	48
f3 min.	17	20	21	26	31	34
f4	4	5		6	7	11
l1 ± 0.2	48.4	56.4	65.4	82.8	101.8	161.8
l2 $+0.5/0$	7		9	11	13	16
l3 min.	24		30	36	45	56
l4 $0/-0.3$	16.3	19.6	22.6	29.1	35.4	60.1

TECHNICAL DATA ARBORS STANDARDS

UNC 1-8

ANSI/CAT

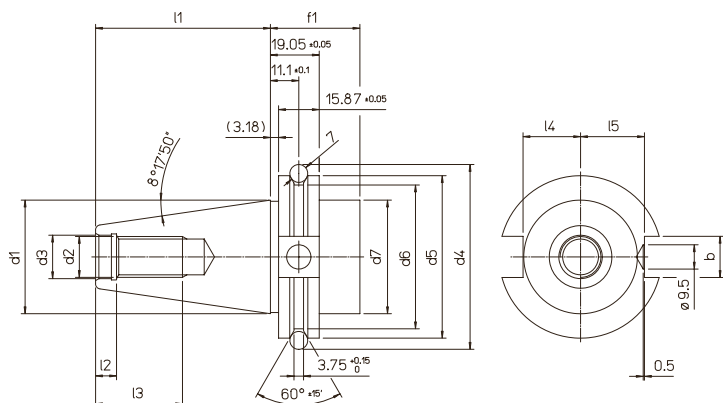

ISO	40	45	50
b +0.2 / 0	16.1	19.3	25.7
d1 6H	44.45	57.15	69.85
d2	M 16 / UNC 5/8-11	M 20 / UNC 3/4-10	M 24 / UNC 1-8
d3 H7	17	21	25
d4 ±0.05	72.3	91.35	108.25
d5 0 / -0.1	63.55	82.55	98.5
d6 0 / -0.5	56.25	75.25	91.25
d7 ±0.15	44.45	57.15	69.95
f1 min	35		38
l1 0 / -0.3	68.4	82.7	101.75
l2 +0.5 / 0	8.2	10	11.5
l3 min.	32	40	47
l4 0 / -0.3	22.8	29.10	35.50
l5 0 / -0.3	25	31.3	37.7

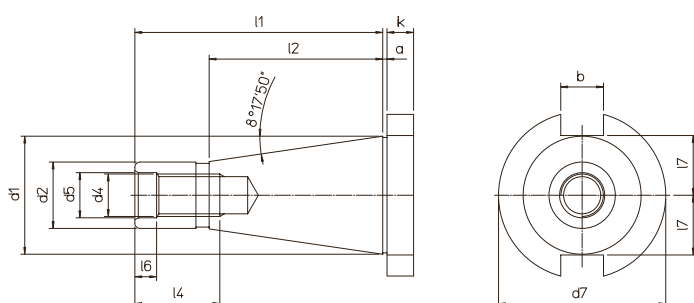

DIN 2080

ISO	30	40	45	50
a ±0.2	1.6		3.2	
b H12	16.1		19.3	25.7
d1	31.75	44.45	57.15	69.85
d2 a10	17.4	25.3	32.4	39.6
d4 ±0.05	M 12	M 16	M 20	M 24
d5	13	17	21	26
d7 0 / -0.4	50	63	80	97.5
k ±0.15	8	10	12	12
l1	68.4	93.4	106.8	126.8
l2	48.4	65.4	82.8	101.8
l4	24	32	40	47
l6 +0.5 / 0	5.5	8.2	10	11.5
l7 max.	16.2	22.5	29	35.3

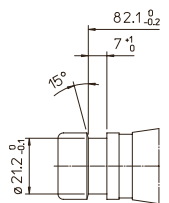

ISO 40 OTT

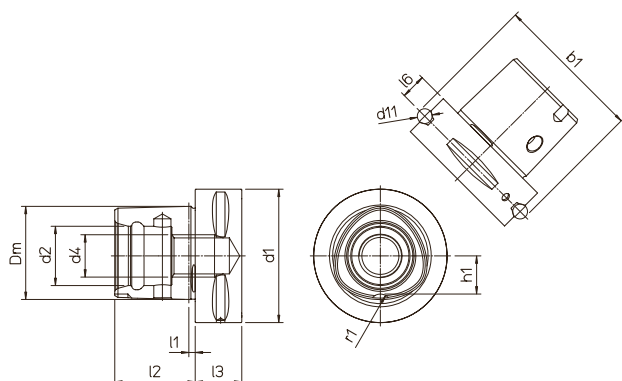

ISO 26623-1

PSC	40	50	63	80
b1 ±0.1	46	59.3	70.7	86
Dm	28	35	44	55
d1 ±0.1	40	50	63	80
d2 +0.1 / -0.05	18	21	28	32
d4	M14x1.5	M16x1.5	M20x2	
d11	5	7		
l1	2.5	3		
l2 ±0.1	24	30	38	48
l3 min	20		22	30
l6 ±0.15	8	10	12	
h1 ±0.1	11	14	18	22.2
r1 ±0.3	4	5	6	7

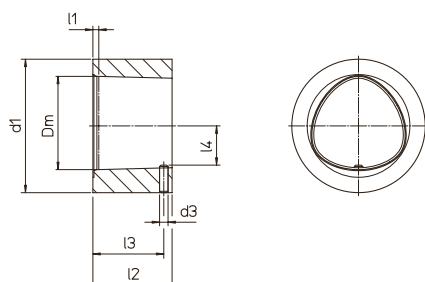

ISO 26623-2

PSC	40	50	63	80
Dm	28	35	44	55
d1 min	40	50	63	80
d3	2.5	3	4	5
l1	2.3	2.8	2.8	2.8
l2 ±0.1	23.4	29.4	37.4	47.4
l3 ±0.2	21	26	33.5	43
l4	11.5 ±0.2	14.5 ±0.2	18.5 ±0.2	22.8 ±0.2

MONOforce

MONOforce high precision ultra-tight toolholders are suitable for rough milling and precision finishing operations. Produced in accordance with the most widespread standards of machine spindles, by using RC reduction collets, it allows a range of use from Ø 3mm to Ø 25mm,

MAX. RPM 15.000

MAX. 40 BAR



DIN 69871 AD

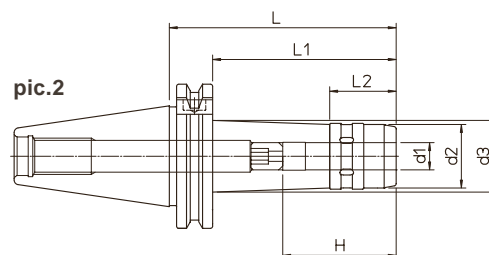
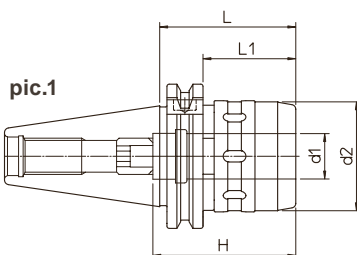
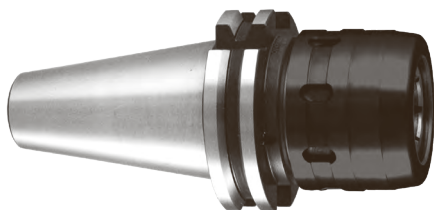

DIN	REF.	CODE	d1	d2	d3	H	L	L1	L2	lb	pic.	METRIC
40	DIN69871-AD40 MF12.100	71DIN-A40MF1210	12	28	32	46	100	81	29.5	2.65	2	
40	DIN69871-AD40 MF20.60	71DIN-A40MF2006	20	48		63	60	41		2.43	1	
40	DIN69871-AD40 MF32.95	71DIN-A40MF3209	32	66		80	95			3.53	1	
50	DIN69871-AD50 MF20.80	71DIN-A50MF2008	20	48		63	80	61		5.07	1	
50	DIN69871-AD50 MF32.75	71DIN-A50MF3207	32	66		90	75	56		6.17	1	

MAS 403 BT AD

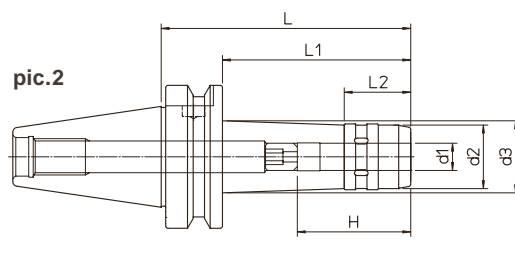
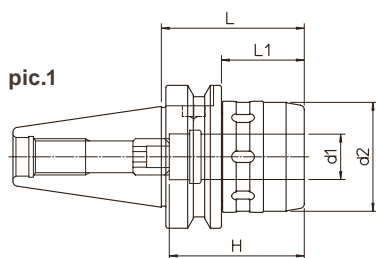

BT	REF.	CODE	d1	d2	d3	H	L	L1	L2	lb	pic.	METRIC
40	MAS403 BT40-AD MF12.100	71MBT-A40MF1210	12	28	32	46	100	73	29.5	3.09	2	
40	MAS403 BT40-AD MF20.65	71MBT-A40MF2007	20	48		63	65	38		2.87	1	
40	MAS403 BT40-AD MF32.90	71MBT-A40MF3209	32	66		80	90			4.63	1	
50	MAS403 BT50-AD MF20.85	71MBT-A50MF2008	20	48		63	85	47		8.16	1	
50	MAS403 BT50-AD MF32.95	71MBT-A50MF3209	32	66		90	95	57		9.70	1	

MAS 403 BT AD FACE CONTACT

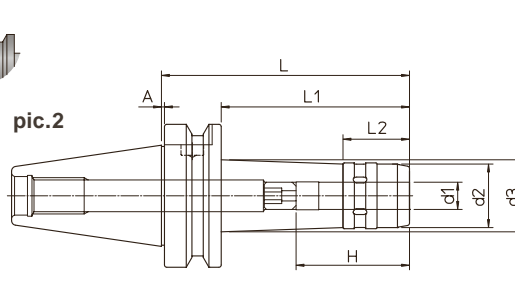
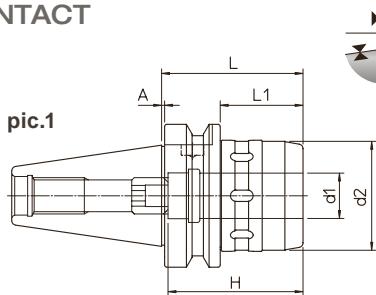

BT	REF.	CODE	d1	d2	d3	H	A	L	L1	L2	lb	pic.	METRIC
40	MAS403 BT40-AD FC MF12.100	71MBF-A40MF1210	12	28	32	46	1	100	73	29.5	3.09	2	
40	MAS403 BT40-AD FC MF20.65	71MBF-A40MF2007	20	48		63	1	65	38		2.87	1	
40	MAS403 BT40-AD FC MF32.90	71MBF-A40MF3209	32	66		80	1	90			4.63	1	
50	MAS403 BT50-AD FC MF20.85	71MBF-A50MF2008	20	48		63	1.5	85	47		8.16	1	
50	MAS403 BT50-AD FC MF32.95	71MBF-A50MF3209	32	66		90	1.5	95	57		9.70	1	

DIN 69893 HSK-A

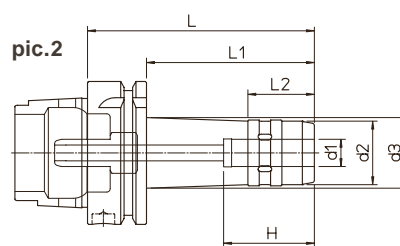
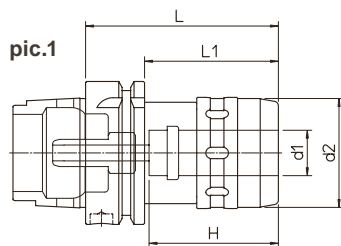

Supplied with coolant tube - Without clamping wrench - Chip prearrangement **METRIC**

HSK-A	REF.	CODE	d1	d2	d3	H	L	L1	L2	lb	pic.			
63	HSK-A63 MF12.100	71HSK-A63MF1210	12	28	32	46	100	74	29.5	2.43	2			
63	HSK-A63 MF20.85	71HSK-A63MF2008	20	48		60	85	59		2.65	1			
63	HSK-A63 MF32.105	71HSK-A63MF3210	32	66		80	105			4.41	1			
100	HSK-A100 MF20.95	71HSKA100MF2009	20	48		60	95	66		6.17	1			
100	HSK-A100 MF32.110	71HSKA100MF3211	32	66		80	110	81		6.83	1			
													INCH	
63	HSK-A63 MF3/4 3.50	71HSK-A63MF1909	3/4	1.89		2.48	3.50	2.48		2.65	1			
63	HSK-A63 MF1-1/4 4.25	71HSK-A63MF3110	1-1/4	2.59		3.15	4.25			4.41	1			
100	HSK-A100 MF3/4 3.75	71HSKA100MF1909	3/4	1.89		2.48	3.75	2.60		6.17	1			
100	HSK-A100 MF1-1/4 4.50	71HSKA100MF3111	1-1/4	2.59		3.15	4.50	3.35		6.83	1			

CAT

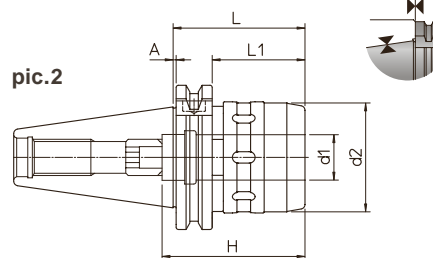
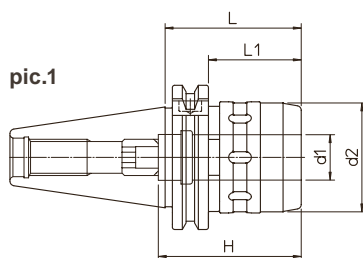

Without clamping wrench - Chip prearrangement **INCH**

CAT	REF.	CODE	d1	d2	H	A	L	L1	lb	pic.			
40	CAT 40 UNC MF 3/4 3.00	71CAT-40-MF1907	3/4	1.89	2.48		3.00	2.25	2.43	1			
40	CAT 40 UNC MF 1-1/4 4.25	71CAT-40-MF3110	1-1/4	2.59	3.15		4.25		3.53	1			
50	CAT 50 UNC MF 3/4 3.00	71CAT-50-MF1907	3/4	1.89	2.48		3.00	1.56	5.07	1			
50	CAT 50 UNC MF 1-1/4 3.25	71CAT-50-MF3108	1-1/4	2.59	3.54		3.25	2.50	6.17	1			
												INCH FACE CONTACT	
40	CAT 40 FC UNC MF 3/4 3.00	71CAF-40-MF1907	3/4	1.89	2.48	1	3.00	2.25	2.43	2			
40	CAT 40 FC UNC MF 1-1/4 4.25	71CAF-40-MF3110	1-1/4	2.59	3.15	1	4.25		3.53	2			
50	CAT 50 FC UNC MF 1-1/4 3.25	71CAT-50-MF3108	1-1/4	2.59	3.54	1.5	3.25	2.50	6.17	2			



PSC - FORCE see p.32

KIT K01 MONOforce 20



- 1 RC 20.06
- 1 RC 20.08
- 1 RC 20.10
- 1 RC 20.12
- 1 RC 20.16
- 1 CHV 50

DIN	REF.	CODE	lb
40	KIT K01 MONOFORCE 20.60 DIN40AD	7KDIN-A40MF2006	4.41
40	KIT K01 MONOFORCE 32.95 DIN40AD	7KDIN-A40MF3209	9.70
50	KIT K01 MONOFORCE 20.80 DIN50AD	7KDIN-A50MF2008	10.14
50	KIT K01 MONOFORCE 32.75 DIN50AD	7KDIN-A50MF3207	13.67

KIT K01 MONOforce 32



- 1 RC 32.06
- 1 RC 32.08
- 1 RC 32.10
- 1 RC 32.12
- 1 RC 32.16
- 1 RC 32.20
- 1 RC 32.25
- 1 CHV 75

BT	REF.	CODE	lb
40	KIT K01 MONOFORCE 20.65 BT40AD	7KMBT-A40MF2007	5.07
40	KIT K01 MONOFORCE 32.90 BT40AD	7KMBT-A40MF3209	10.14
50	KIT K01 MONOFORCE 20.85 BT50AD	7KMBT-A50MF2008	11.90
50	KIT K01 MONOFORCE 32.95 BT50AD	7KMBT-A50MF3209	16.53

ON REQUEST **KIT K01** FACE CONTACT

HSK-A	REF.	CODE	lb
63	KIT K01 MONOFORCE 20.85 HSK63	7KHSK-A63MF2008	5.07
63	KIT K01 MONOFORCE 32.105 HSK63	7KHSK-A63MF3210	9.92
100	KIT K01 MONOFORCE 32.110 HSK100	7KHSKA100MF3211	14.77

SPARE PARTS

SISTEM MHD'

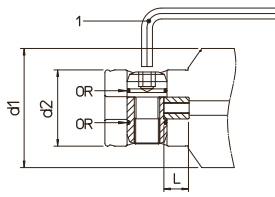

pic. 1

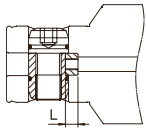

pic. 2

REF.	CODE	d1	d2	CODE 1	CODE OR	L	pic.
MHD' 16	381725001161	16	10	101500100250		2	2
MHD' 20	381725001201	20	13	101500100300		2.5	2
MHD' 25	381725001251	25	16	101500100300		3	2
MHD' 32	381725001321	32	20	101500100400	101254007510	3.55	2
MHD' 40	381725001401	40	25	101500100500	101254010010	4	2
MHD' 50 RD 50 / .. TRM - TRC - TR-E	381725001501	50	32	101500100600	101254013010	4.2	2
MHD' 50	381725001001	50	32	101500100600	101254013010	12.2	1
MHD' 63-80 RD 63 / .. TRM - TRC	381725001502	63-80	42	101500100800	101251002075	4.9	2
MHD' 63-80	381725001002	63-80	42	101500100800	101251002075	13.85	1

MHD' - PSC / TRM

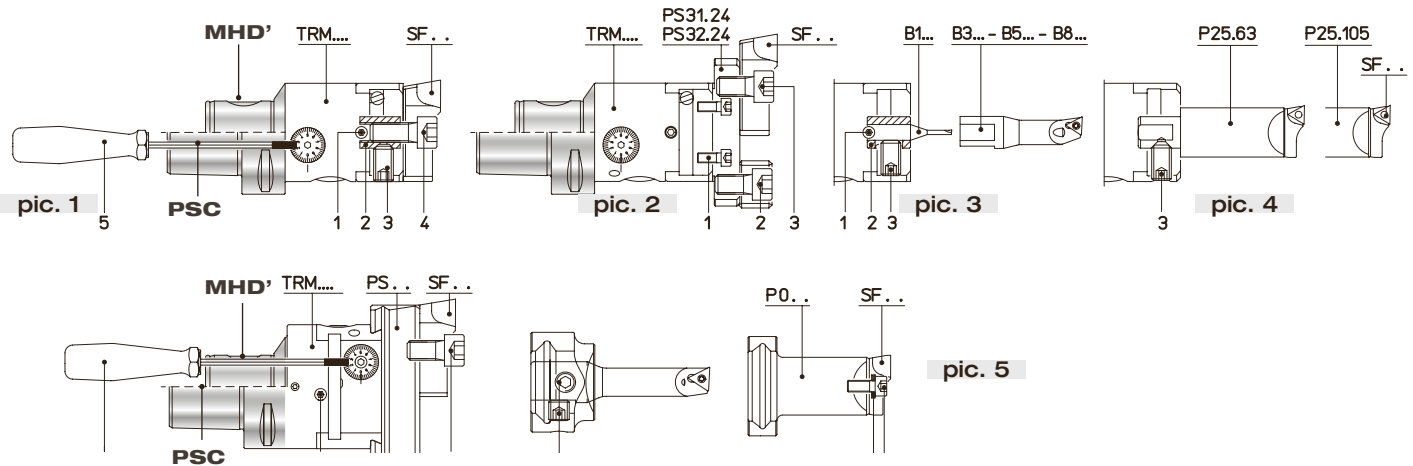

REF.	CODE 1	CODE 2	CODE 3	CODE 4	CODE 5	CODE 6	pic.
TRM 16 MHD'	200100190301			100051030006	101500800150		1
TRM 20 MHD'	200100190301			100051040008	101500800150		1
TRM 25 MHD'	100271040004			100051050010	101500800200		1
TRM 32 MHD'	100271040006			100051060012	101500800200		1
TRM 40 MHD'	100271050005			100051080014	101500800250		1
TRM 50 MHD' PSC50-TRM50 PSC63-TRM50	100271050008	201041015002	100231100016	100051100025	101500800250		1
TRM 50 MHD' PSC50-TRM50 PSC63-TRM50	200100150501	100051100020	100051100020		101500800250		2
TRM 50 MHD' PSC50-TRM50 PSC63-TRM50	100271050008	200560116082	100231100016		101500800250		3-4
TRM 63 MHD' PSC63-TRM63	100251060010	100051100018	100251080008	100051050012	101500800300	100800100530	5
TRM 80-MHD' PSC63-TRM80	100251060014	100051100018	100251080008	100051050012	101500800300	100800100530	5
TRM 125 MHD'	100251060020	100051100025		100051060018	101500800300	100800100640	5

TRE 50

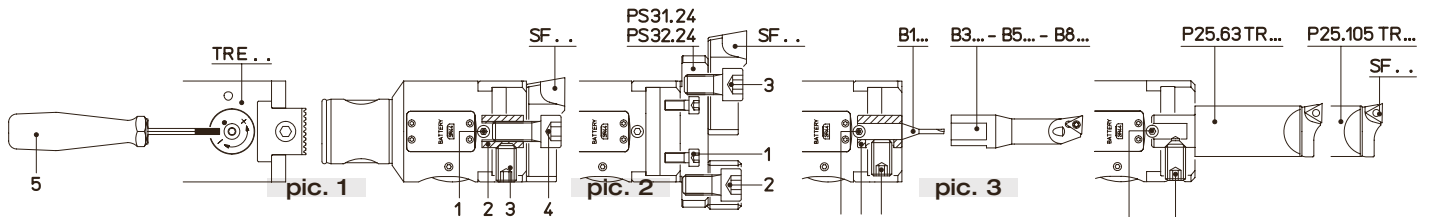

REF.	CODE 1	CODE 2	CODE 3	CODE 4	CODE 5	pic.
TRE 50	100238060010	201041015002	100231100016	100051100025	101500800250	1
TRE 50	200100150501	100051100020	100051100020			2
TRE 50	100238060010	200560116082	100231100016			3

MHD' - PSC / TS

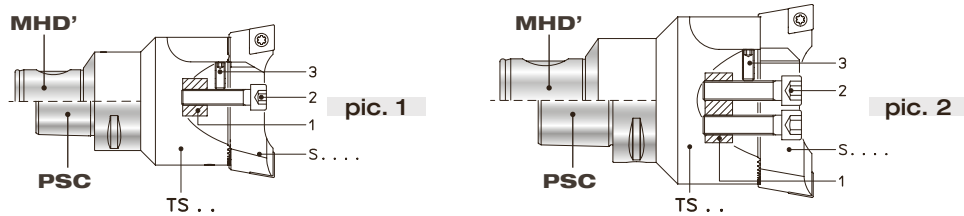

REF.	CODE 1	CODE 2	CODE 3	pic.
TS 16/16 MHD'	201430110008	100051030014	100231030004	1
TS 20/20 MHD'	201430110009	100051040015	100231030005	1
TS 25/25 MHD'	201430110032	100051040020	100231030008	1
TS 32/32 MHD'	201430110031	100051050025	100231040012	1
TS 40/40 MHD'	201430110029	100051060030	100231050014	1
TS 50/50 MHD' - PSC50-TS50 / PSC63-TS50	201430110013	100051080035	100231050012	1-2
TS 50/63 MHD'	201430110030	100051100040	100231060016	2
TS 63/63 MHD' - PSC63-TS63	201430110030	100051100040	100231060016	1-2
TS 80/80 MHD' - PSC63-TS80	201430110015	100051120045	100231080025	1-2
TS 80/90 MHD'	201430110015	100051120045	100231080025	1-2

BHT 250 - 500 - 750

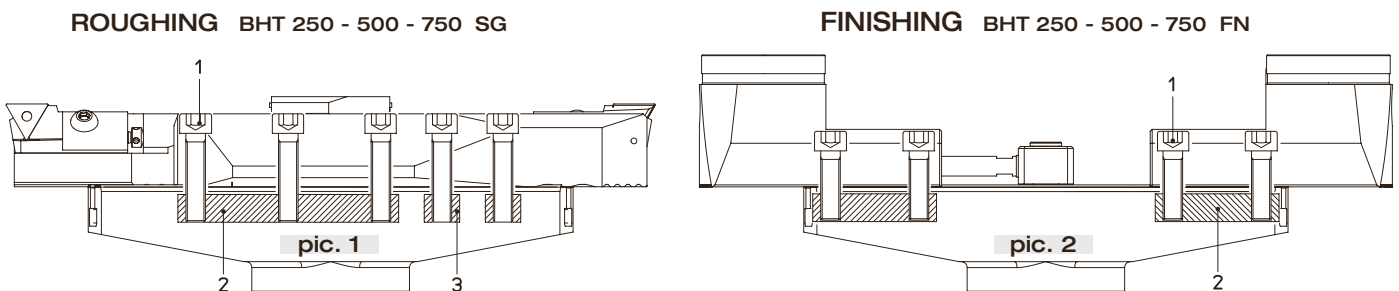

REF.	CODE 1	CODE 2	CODE 3
ROUGHING pic. 1	BHT 250 - 500 - 750 SG	100051100045	201430100065
FINISHING pic.2	BHT 250 - 500 - 750 FN	100051100035	201430100067

SPARE PARTS

PE - MHD' ER DIN 6499

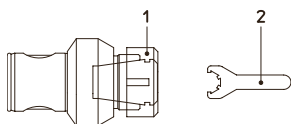

REF.	CODE 1	CODE 2
PE 20 / ER16M	100451011600	101501001600
PE 32 / ER25M	100451012500	101501002500
PE 40 / ER25	100451032500	101501002501
PE 50 / ER25	100451032500	101501002501
PE 50 / ER32	100451033200	101501003201
PE 63 / ER32	100451033200	101501003201

PE - PSC / MONOd ER DIN 6499

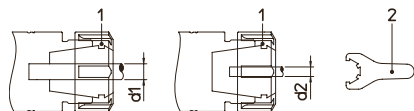

REF.	CODE 1	d1	CODE 2	d2
ER 16 M	100451011600	5 ~ 10	101501001600	1 ~ 4
ER 25	100451032500	8 ~ 16	101501002501	2 ~ 7
ER 32	100451033200	8 ~ 20	101501003201	3 ~ 7

AW DIN 1835 B-E

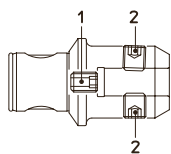

REF.	CODE 1	CODE 2
AW 50/6	200100190808	200100190610
AW 50/8	200100190808	200100190810
AW 50/10	200100190809	200100191012
AW 50/12	200100190809	200100191216
AW 50/14	200100190809	200100191216
AW 50/16	200100191215	200100191416
AW 50/20	200100191215	200100191616
AW 50/25	200100191615	200100191820
AW 63/16	200100191215	200100191416
AW 63/20	200100191215	200100191616
AW 63/25	200100191615	200100191820
AW 63/32	200100191615	200100192020
AW 80/40	200100192019	200100192020

PSC

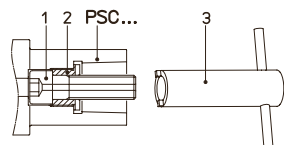

PSC	CODE 1	CODE 2	CODE 3
40	200101151448	201032215005	101501402101
50	200101151658	201032515005	101501402401
63	200101152071	201033015021	101501403001
80	200101152071	201033015021	101501403001

PF INCH

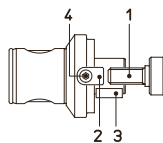

REF.	CODE 1	CODE 2	CODE 3	CODE 4
PF 50-3/4 INCH	201080295001	201101807901	201101803501	100051040010
PF 50-1 INCH	201080212001	201101809501	201101800601	100051050012
PF 63-3/4 INCH	201080295001	201101807901	201101803501	100051040010
PF 63-1 INCH	201080212001	201101809501	201101800601	100051050012
PF 63 1-1/4 INCH	201080216001	201101812401	201101800702	100051060014
PF 80 1-1/2 INCH	201080219001	201101815901	201101800903	100051060018
PF 80-2 INCH	201080225001	201101818701		100051060025

PF MHD' - PSC METRIC

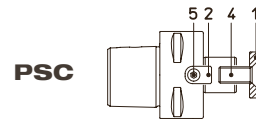
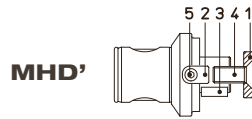

REF.	CODE 1	CODE 2	CODE 3	CODE 4	CODE 5
PF 40/16	201010085010	201101800801	101001040014	100101080025	100051030008
PF 40/22	201010105030	201101801002	101001060016	100101100025	100051040010
PF 50/16	201010085010	201101800801	101001040014	100101080025	100051030008
PF 50/22 MHD' / PSC50-PF22.25	201010105030	201101801002	101001060016	100101100025	100051040010
PF 50/27 MHD' / PSC50-PF27.25	201010125030	201101801202	101001070018	100101120030	100051050012
PF 50/32	201010165020	201101801402	101001080020	100101160035	100051060016
PF 63/22	201010105030	201101801002	101001060016	100101100025	100051040010
PF 63/27 MHD' / PSC63-PF27.25	201010125030	201101801202	101001070018	100101120030	100051050012
PF 63/32 MHD' / PSC63-PF32.25	201010165020	201101801402	101001080020	100101160035	100051060016
PF 80/32 MHD' / PSC80-PF32.30	201010165020	201101801402	101001080020	100101160035	100051060016
PF 80/40 MHD' / PSC80-PF40.45	201010210010	201101801603	101001100025	100101200045	100051060018
PF 80/50	201010260330	201101801802	101001120028	100101240050	100051060020
PF 80/60		201101802510	101001140036		100051120025

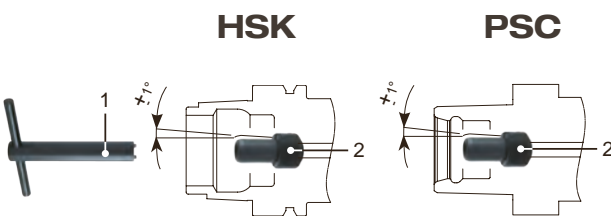

REF.	CODE 1	CODE 2
HSK-A50	101501101400	382019010001
HSK-A63	101501101600	382019012001
HSK-A80	101501101800	382019014001
HSK-A100	101501102200	382019016001
PSC 40	101501200700	382020006001
PSC 50	101501200800	382020007001
PSC 63	101501200900	382020008001
PSC 80	101501201100	382020010001

PSC - TU ISO 26623-1

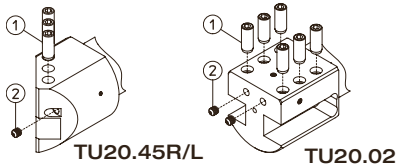

REF.	CODE 1	CODE 2
TCD' PSC 50 TU20.45R/L	100231120025	100585010800
TCD' PSC 63 TU25.45R/L	100231120025	100585010800
TCD' PSC 80 TU32.45R/L	100231120025	100585010800
TCD' PSC 50 TU20.02	100231120025	100585010800
TCD' PSC 63 TU25.02	100231120025	100585010800
TCD' PSC 80 TU32.02	100231120025	100585010800

PSC - D... ISO 26623-1

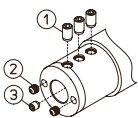

REF.	CODE 1	CODE 2	CODE 3
TCD' PSC 50 D.25x80	100231100016	100585010800	
TCD' PSC 63 D.25x80	100231100016	100585010800	
TCD' PSC 63 D.40x125	100231120020	100585010800	100231080008
TCD' PSC 80 D.25x85	100231100016	100585010800	
TCD' PSC 80 D.40x125	100231120020	100585010800	100231080008

PSC - TU ISO 26623-1

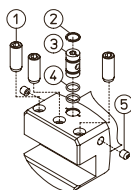

REF.	CODE 1	CODE 2	CODE 3	CODE 4	CODE 5
TCD' PSC 63 TU20.90	100231120025	100900301400	201462501400	101251002043	100580610180
TCD' PSC 63 TU25.90	100231120025	100900301400	201462501400	101251002043	100580610180
TCD' PSC 80 TU32.90	100231120025	100900301400	201462501400	101251002043	100580610180

SS.. 95

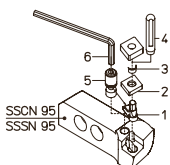

REF.	CODE 1	CODE 2	CODE 3	CODE 4	CODE 5	CODE 6
SSCN 95 491111190600	492031190600	100655095112	101501301408	494311190600	101500100400	
SSSN 95 491111190600	492035190600	100655095112	101501301408	494311190600	101500100400	

SPARE PARTS

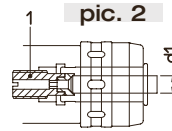
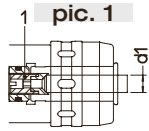

pic.	REF. INCH	CODE 1	d1
1	VCR 3/4 MONOforce 3/4 CAT 40-50	382041019069	1/4 ~ 7/16
		382041019129	1/2 ~ 3/4
2	VCR 3/4 MONOforce 3/4 CAT 40-50	382041019063	1/4 ~ 7/16
		382041019127	1/2 ~ 3/4
1	VCR 1-1/4 MONOforce 1-1/4 CAT 40-50	382041031099	3/8 ~ 1/2
		382041031159	5/8 ~ 3/4
		382041031259	1 ~ 1-1/4
2	VCR 1-1/4 MONOforce 1-1/4 CAT 40-50	382041031095	3/8 ~ 1/2
		382041031158	5/8 ~ 3/4
		382041031254	1 ~ 1-1/4

pic.	REF. METRIC	CODE 1	d1
1	VCR 20 MONOforce 20 HSK63-100 MHD'50 PSC 63-80	382041020032	3 ~ 5
		382041020062	6 ~ 12
		382041020142	14 ~ 20
1	VCR 32 MONOforce 32 HSK63-100 MHD'63 PSC 63-80	382041032033	3 ~ 5
		382041032063	6 ~ 12
		382041032143	14 ~ 20
		382041032253	25 ~ 32
2	VCR 20 MONOforce 20 DIN/BT-40-50	382041020031	3 ~ 5
		382041020061	6 ~ 12
		382041020141	14 ~ 20
2	VCR 32 MONOforce 32 DIN/BT-40	382041032031	3 ~ 5
		382041032061	6 ~ 12
		382041032141	14 ~ 20
		382041032251	25 ~ 32
2	VCR 32 MONOforce 32 DIN/BT-50	382041032032	3 ~ 5
		382041032062	6 ~ 12
		382041032142	14 ~ 20
		382041032252	25 ~ 32

FORCE GH - VT INCH / METRIC SEALING DEVICE FOR HIGH PRESSURE COOLANT SUPPLY

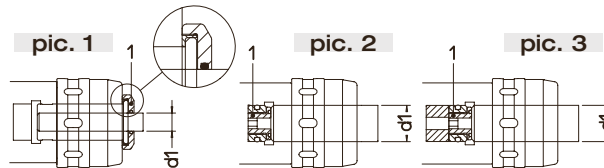

pic.	REF. INCH	CODE 1	d1
1	GH 3/4 MONOforce 3/4 CAT 40-50 MHD'50	382042019063	1/4
		382042019079	5/16
		382042019095	3/8
		382042019111	7/16
		382042019127	1/2
		382042019158	5/8
2	VT 3/4.3/4 MONOforce 3/4 CAT 40-50	382042019190	3/4
1	GH 1-1/4 MONOforce 1-1/4 CAT 40-50 MHD'63	382042031095	3/8
		382042031127	1/2
		382042031158	5/8
		382042031190	3/4
		382042031254	1
2	VT 1-1/4.1-1/4 MONOforce 1-1/4 CAT 40-50	382042031317	1-1/4

pic.	REF. METRIC	CODE 1	d1
1	GH 20 MONOforce 20 HSK63 MHD'50 / DIN/BT-40-50 PSC 63 - 80	382042020061	6
		382042020081	8
		382042020101	10
		382042020121	12
		382042020141	14
		382042020161	16
2	VT 20.20 MONOforce 20 DIN/BT-40-50 HSK63-100 PSC 63-80	382042020201	20
1	GH 32 MONOforce 32 DIN/BT-40-50 / HSK63-100 MHD'63 PSC 63-80	382042032061	6
		382042032081	8
		382042032101	10
		382042032121	12
		382042032141	14
		382042032161	16
		382042032181	18
382042032201	20		
382042032251	25		
2	VT 32.32 MONOforce 32 DIN/BT-40 HSK63-100 PSC 63-80	382042032321	32
3	VT 32.32.100 MONOforce 32 DIN/BT-50	382042032322	32

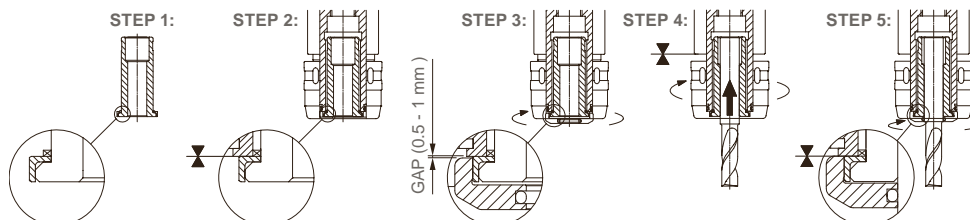

RC INCH / METRIC COLLETS ULTRA-TIGHT SPINDLE

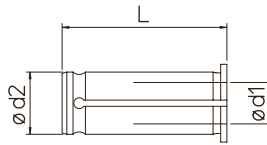

0.003

ød2	REF. INCH	CODE	d1	L
3/4	RC 3/4.1/4	497080019063	1/4	1.97
3/4	RC 3/4.5/16	497080019079	5/16	1.97
3/4	RC 3/4.3/8	497080019095	3/8	1.97
3/4	RC 3/4.7/16	497080019111	7/16	1.97
3/4	RC 3/4.1/2	497080019127	1/2	1.97
3/4	RC 3/4.5/8	497080019158	5/8	1.97
<hr/>				
3/4	RC 3/4.06	497080019060	6	1.97
3/4	RC 3/4.08	497080019080	8	1.97
3/4	RC 3/4.10	497080019100	10	1.97
3/4	RC 3/4.12	497080019120	12	1.97
3/4	RC 3/4.14	497080019140	14	1.97
3/4	RC 3/4.16	497080019160	16	1.97
<hr/>				
1-1/4	RC 1-1/4.1/4	497080031063	1/4	2.48
1-1/4	RC 1-1/4.3/8	497080031095	3/8	2.48
1-1/4	RC 1-1/4.1/2	497080031127	1/2	2.48
1-1/4	RC 1-1/4.5/8	497080031158	5/8	2.48
1-1/4	RC 1-1/4.3/4	497080031190	3/4	2.48
1-1/4	RC 1-1/4.1	497080031254	1	2.48
<hr/>				
1-1/4	RC 1-1/4.10	497080031100	10	2.48
1-1/4	RC 1-1/4.12	497080031120	12	2.48
1-1/4	RC 1-1/4.16	497080031160	16	2.48
1-1/4	RC 1-1/4.18	497080031180	18	2.48
1-1/4	RC 1-1/4.20	497080031200	20	2.48
1-1/4	RC 1-1/4.25	497080031250	25	2.48

ød2	REF. METRIC	CODE	d1	L
12	RC12.03	497080012030	3	44
12	RC12.04	497080012040	4	44
12	RC12.06	497080012060	6	44
12	RC12.08	497080012080	8	44
12	RC12.10	497080012100	10	44
<hr/>				
20	RC20.03	497080020030	3	50
20	RC20.04	497080020040	4	50
20	RC20.05	497080020050	5	50
20	RC20.06	497080020060	6	50
20	RC20.08	497080020080	8	50
20	RC20.10	497080020100	10	50
20	RC20.12	497080020120	12	50
20	RC20.14	497080020140	14	50
20	RC20.16	497080020160	16	50
<hr/>				
32	RC32.03	497080032030	3	63
32	RC32.04	497080032040	4	63
32	RC32.05	497080032050	5	63
32	RC32.06	497080032060	6	63
32	RC32.08	497080032080	8	63
32	RC32.10	497080032100	10	63
32	RC32.12	497080032120	12	63
32	RC32.14	497080032140	14	63
32	RC32.16	497080032160	16	63
32	RC32.18	497080032180	18	63
32	RC32.20	497080032200	20	63
32	RC32.25	497080032250	25	63

RC SEALED collet on request

FORCE INCH / METRIC

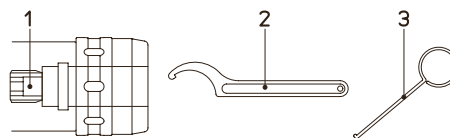

REF. INCH	CODE 1	CODE 2	CODE 3
FORCE 3/4	200100191582	101500400050	201271600400
FORCE 1-1/4	200100191582	101500400075	201271600400

REF. METRIC	CODE 1	CODE 2	CODE 3
FORCE 12	200100191014	101500400028	201271600400
FORCE 20	200100191615	101500400050	201271600400
FORCE 32	200100191615	101500400075	201271600400

U-TRONIC

Medium and large Numerical Control heads, applicable on boring machines, machining centers and special machines. These offer the capabilities of different and additional machining operations, both internal and external. The slide movement is managed by an integrated servomotor and directly connected to the NC. The application on machines could be manual or automatic thanks to an interface flange.

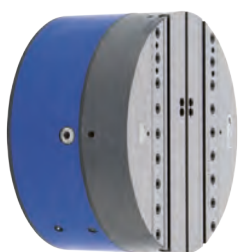
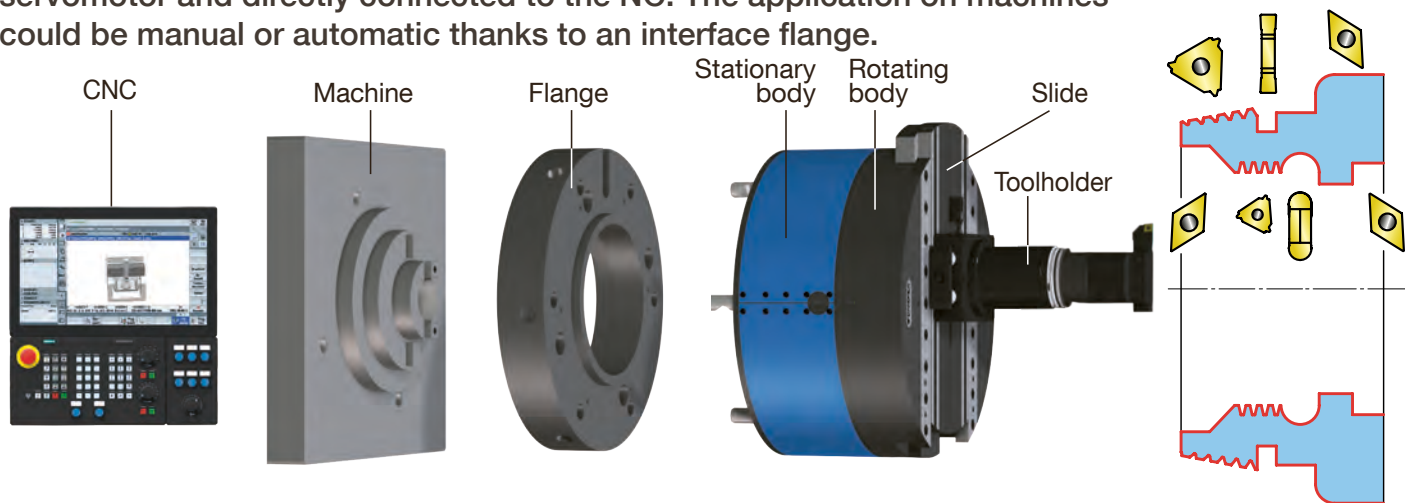

UT 5-500
Ø max 39.37



UT 5-630
Ø max 49.21

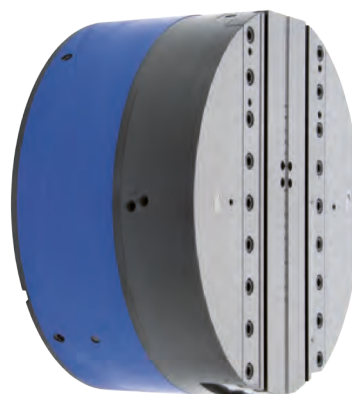

UT 8-800
Ø max 62.99

UT 8-1000
Ø max 78.74

UT 8-1250
Ø max 98.43

UT 8-1600
Ø max 125.98

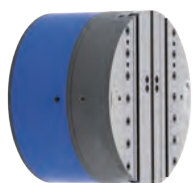

UT 3-360
Ø max 31.50

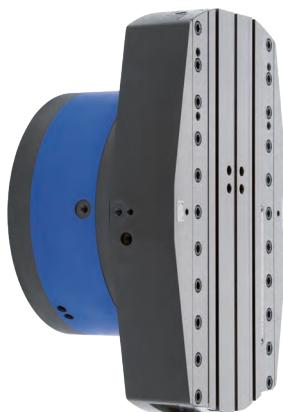

UT 5-800
Ø max 62.99

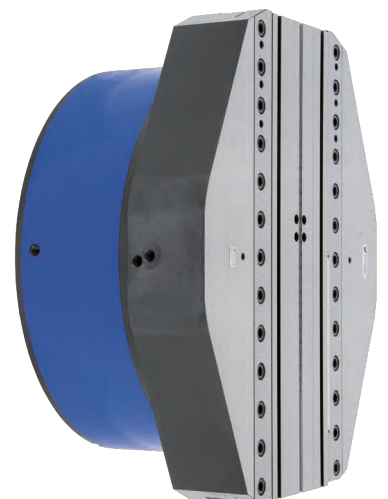

STANDARD

EXTENDED

ANGULAR HEADS

GEARBOX

HOLE

DOUBLE SLIDE

HIGH SPEED (BALANCED)

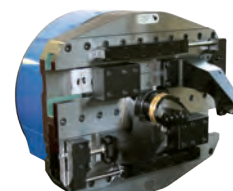
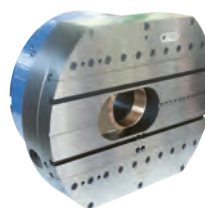

SPECIALS

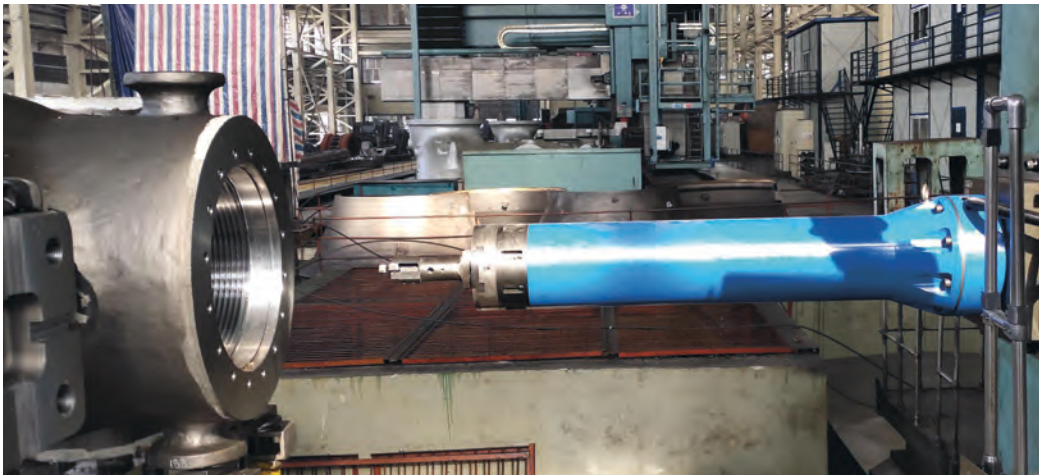
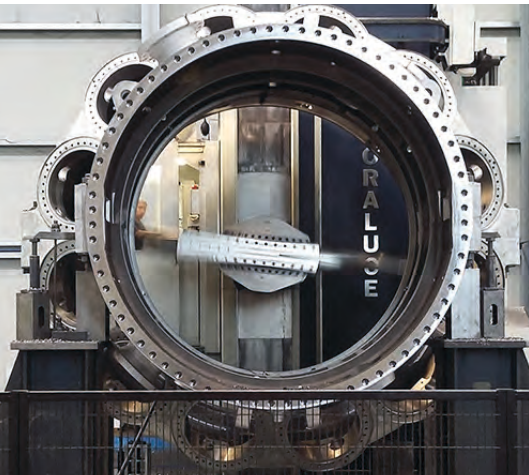
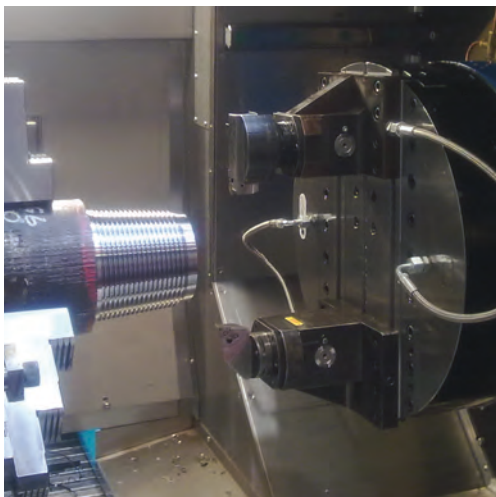
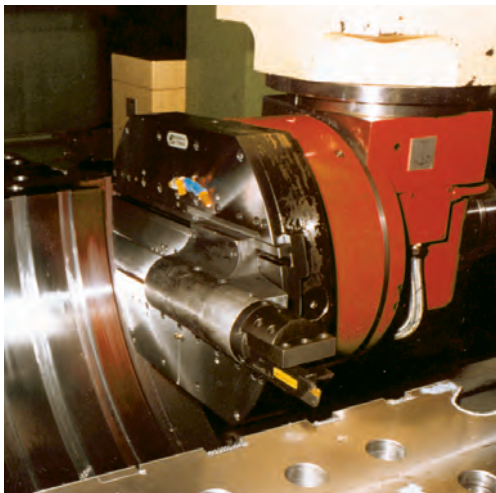
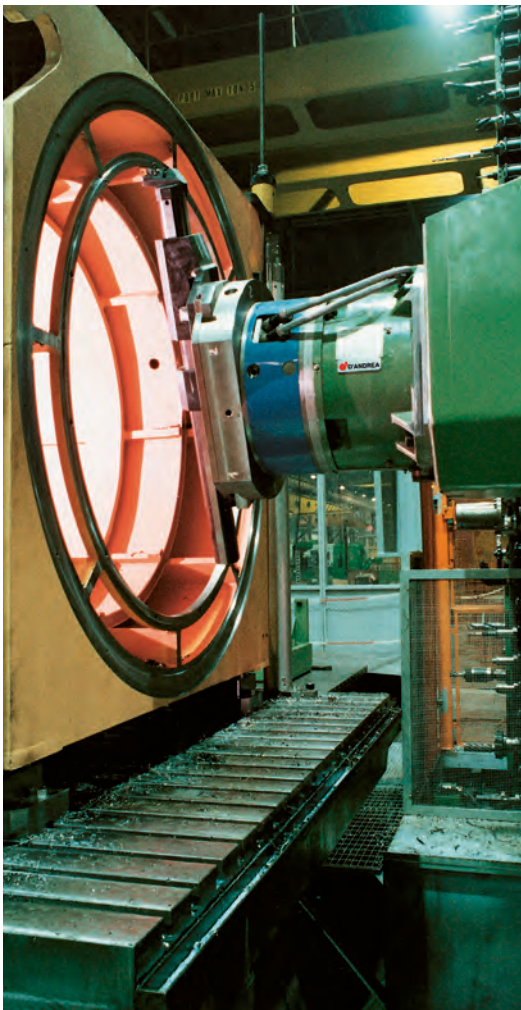
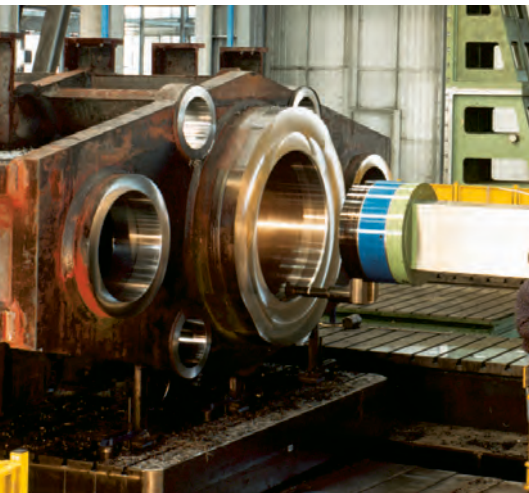
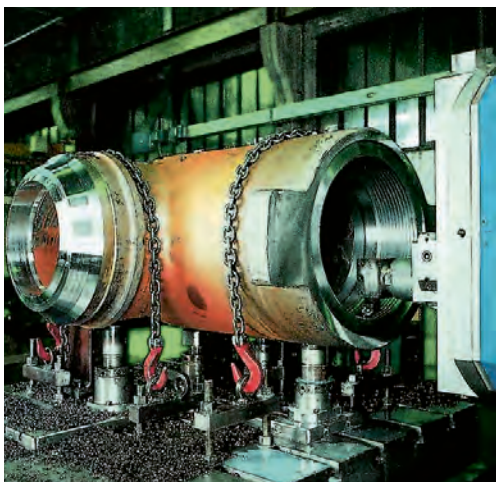
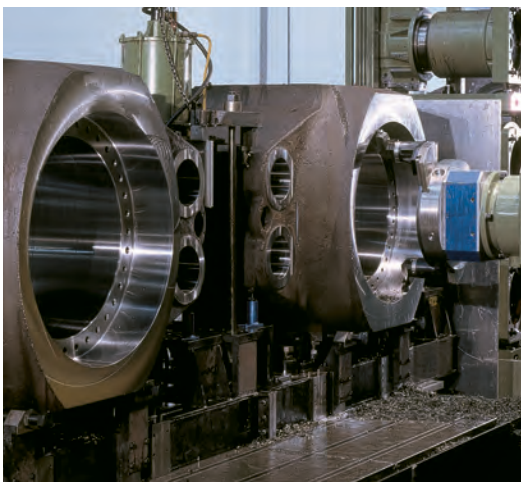

U-TRONIC

COMMAND

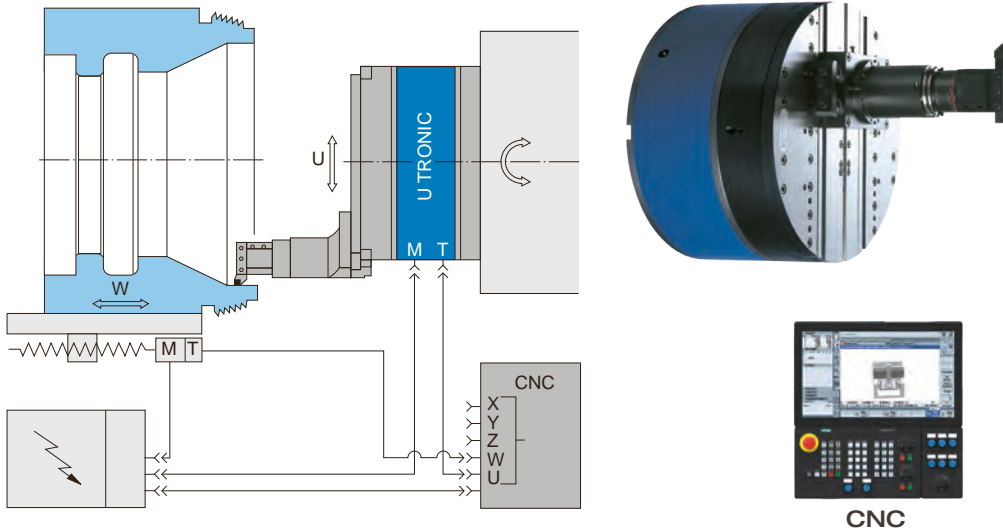

The control of the U-TRONIC heads takes place through the direct connection to the "U" axis of the machine numerical control. Through the interpolation of the axes, it offers the capabilities to perform any type of turning, boring, radiusing and spherical operations.

COMPONENTS

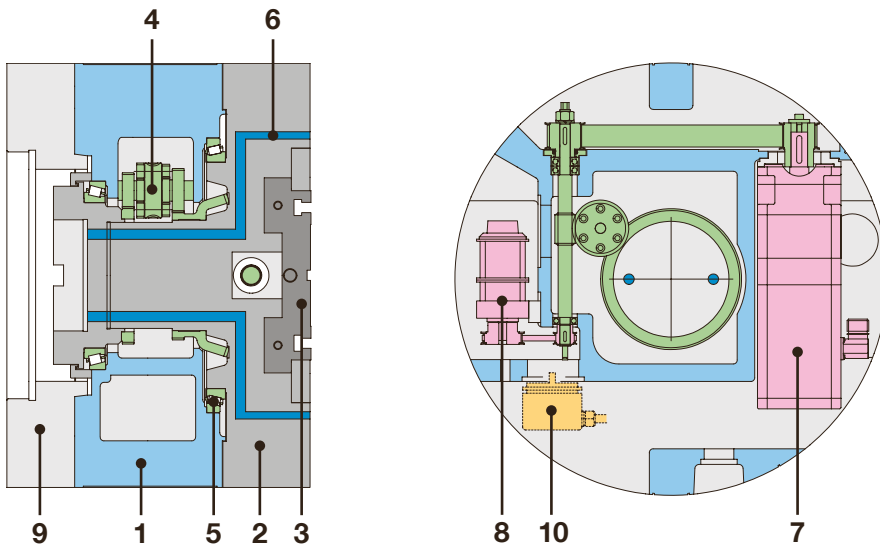

1. Stationary body
2. Rotating body
3. Tool slide
4. Gears
5. Bearings
6. Coolant way
7. Servomotor
8. Limit switches
9. Flange
10. Encoder on request

PREARRANGEMENTS

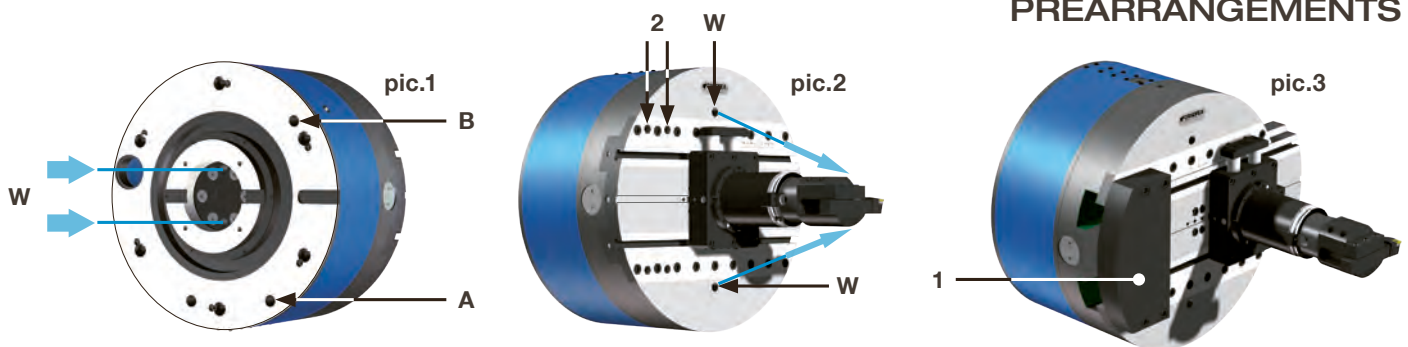

A-Internal pressurization pic.1
To prevent liquid and dust from getting into the motor, transducer, and limit switch areas, an $\varnothing .33$ (A) hole is provided for internal pressurization of the fixed body with an air inlet at 7-15 PSI.

B-Automatic greaser pic.1
A $\varnothing .33$ (B) hole is provided on the head so that grease can be automatically put in the U-TRONIC.

Coolant supply pic.1-2
Internal coolant channels (W) are provided inside the U-TRONIC head that allow coolants to pass through from the machine spindle until the two threaded holes located next to the slide (W). Hoses can be screwed on these holes to bring coolant directly to the tool. **Max pressure 580 PSI.**

Balancing pic.3
To improve working conditions and balance the tool position when it appears shifted in relation to the U-TRONIC axis, counterweights (1) can be applied using the threaded holes (2) located on the rotating body.

APPLICATION

U-TRONIC is applied manually or automatically by using a flange for fastening to the machine tool and a driving plate for the rotary body rotation.

It is applied manually using a flange for fastening with a cam lock quick coupling, or automatically with a palletized system and special connectors.

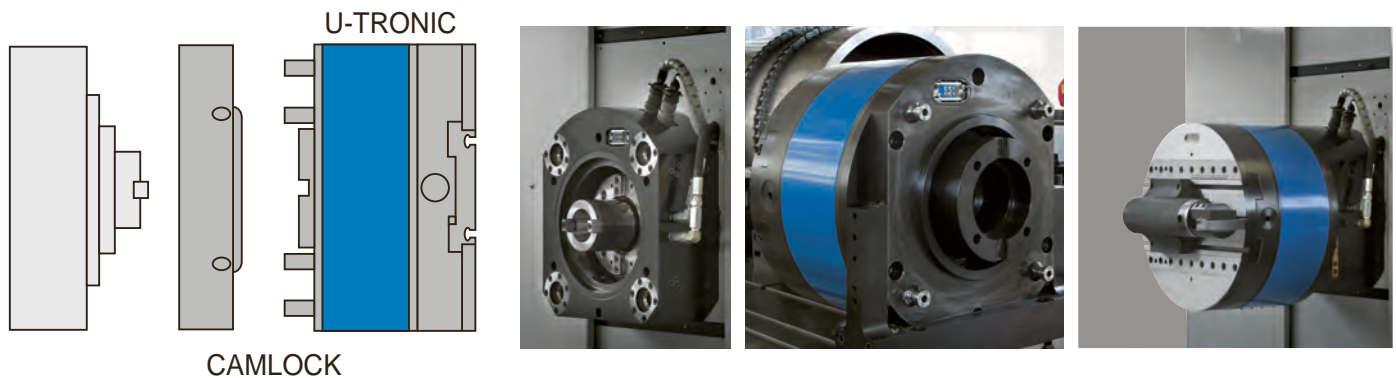

The following layout shows the basic information for the flange manufacturing with cam lock rapid coupling. The U-TRONIC UT 8-800 S and UT 8-1000 S do not include the fastening with a cam lock quick coupling.

U-TRONIC 3-360 S

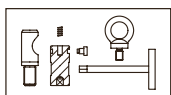

REF	CODE
KIT CAMLOCK UT 360	394200136000
n°6 VTC 8x12	100051080012
n°1 EYEBOLT M10 UT BASE 3	100541100100
n°6 SPRING UT BASE 3-5	100551060023
n°1 KEY FOR CAM 6 UT BASE 3	101500701200
n°6 CAMLOCK PIN 6 UT BASE 3	101601010600
n°6 CAMLOCK CAM 6 UT BASE 3	101601020600
n°6 PIN FOR CAM 6 UT BASE 3	200100150817

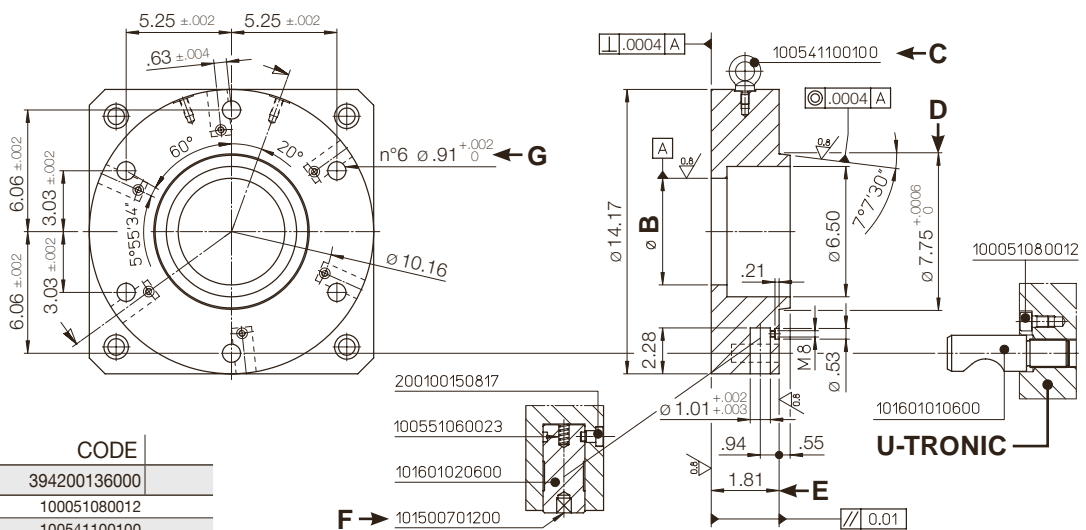

B Spindle centering C Eyebolt D Control with gauge E Measurement to control depending on spindle protrusion F Spanner G Bores min. depth 46

The following layout shows the basic information for the flange manufacturing with cam lock rapid coupling. The U-TRONIC UT 8-800 S and UT 8-1000 S do not include the fastening with a cam lock quick coupling.

U-TRONIC 5-500 / 5-630 / 5-800 S

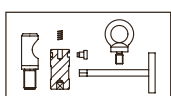

REF	CODE
KIT CAMLOCK UT 500	394200150000
n°6 VTC 8x14	100051080014
n°1 EYEBOLT M16 UT BASE 5	100541100160
n°6 SPRING UT BASE 3-5	100551060023
n°1 KEY FOR CAM 8 UT BASE 5	101500701400
n°6 CAMLOCK PIN 8 UT BASE 5	101601010800
n°6 CAMLOCK CAM 8 UT BASE 5	101601020800
n°6 PIN FOR CAM 8 UT BASE 5	200100150818

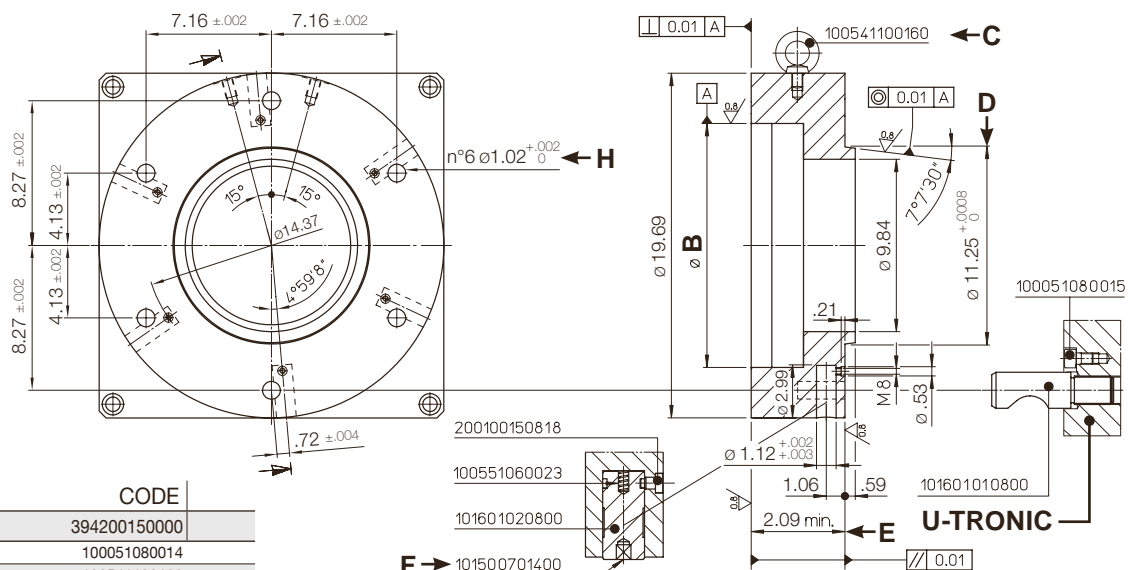

B Spindle centering C Eyebolt D Control with gauge E Measurement to control depending on spindle protrusion F Spanner H Bores min. depth 53

U-TRONIC TOOLHOLDERS AND ACCESSORIES PSC-MHD'

UT 3-360 / 5-500 / 5-630 / 5-800 / 8-800 / 8-1000 S

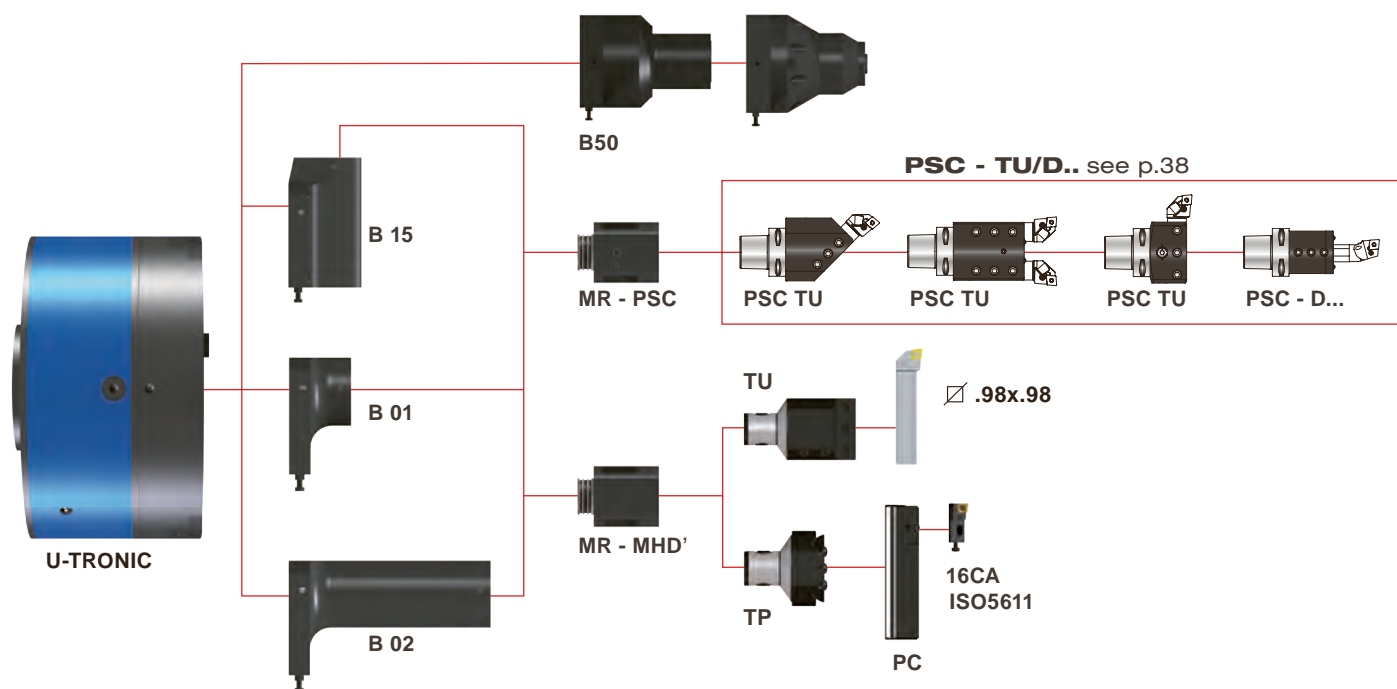

B01 / B02 / B15 - PSC / MHD'

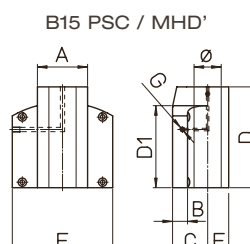
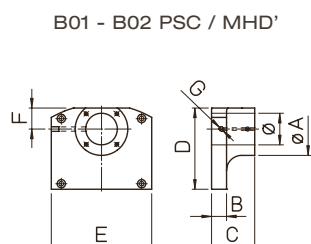
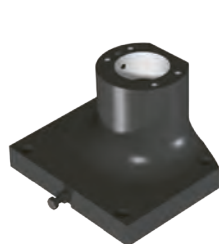

U-TRONIC	REF.	CODE	Ø ^{H7}	A	B	C	D	D1	E	F	G	lb
UT 3-360 S	B01 PSC63-MHD'80	443006300310	2.48	4.13	.98	1.77	5.39	5.91	1.65	G1/8'	7.72	
	B02 PSC63-MHD'80	443006301610	2.48	4.13	1.06	6.34	5.39	5.91	1.65	G1/8'	22.05	
	B15 PSC63-MHD'80	445006301210	2.48	4.13	1.26	2.36	4.76	5.91	1.65	G1/8'	22.05	
UT 5-500 / 5-630 / 5-800 S	B01 PSC63-MHD'80	443006300861	2.48	4.13	1.18	3.39	6.57	7.87	1.65	G1/8'	24.25	
	B02 PSC63-MHD'80	443006303310	2.48	4.13	1.18	13.03	6.57	7.87	1.65	G1/8'	24.25	
	B15 PSC63-MHD'80	445006302010	2.48	4.13	1.22	2.76	6.57	6.69	7.87	1.65	G1/8'	14.33
UT 8-800 / 8-1000 S	B01 PSC80-MHD'80	443007500710	2.95	5.24	1.18	2.80	7.28	7.87	1.97	G1/8'	23.15	
	B02 PSC80-MHD'80	443007503160	2.95	5.24	1.26	2.80	9.25	7.87	1.97	G1/8'	74.96	
	B15 PSC80-MHD'80	445007502620	2.95	5.24	1.18	12.44	9.25	7.87	7.87	1.97	G1/8'	70.55
UT 8-800 / 8-1000 S	B01 PSC80-MHD'80	443007501460	2.95	5.24	1.18	5.75	7.56	9.84	1.97	G1/4'	41.89	
	B02 PSC80-MHD'80	443007506360	2.95	5.24	1.77	25.04	7.56	9.84	1.97	G1/4'	154.32	
	B15 PSC80-MHD'80	445007503000	2.95	5.24	1.18	3.35	11.81	7.87	9.84	1.97	G1/4'	81.57

MR - PSC / MHD'

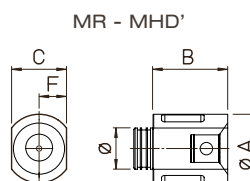
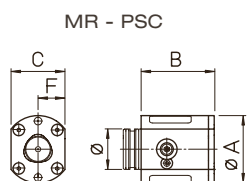

U-TRONIC	REF.	CODE	Øg6	PSC	MHD'	A	B	C	F	lb
UT 3 / 5 ... S	MR - PSC 63	450206301050	2.48	2.48		4.13	4.49	3.31	1.65	13.23
UT 3 / 5 ... S	MR - MHD' 80/105	450208001050	2.48		3.15	4.13	4.49	3.31	1.65	14.33
UT 5 / 8 ... S	MR - PSC 80	450208001335	2.95	3.15		5.12	5.08	3.94	1.97	24.25
UT 8 ... S	MR - MHD' 80/133	450208001330	2.95		3.15	5.12	5.08	3.94	1.97	24.25

TOOLHOLDERS AND ACCESSORIES PSC-MHD'

K03 PSC 63-80

1 B 01
1 B 02
1 B 15
1 MR

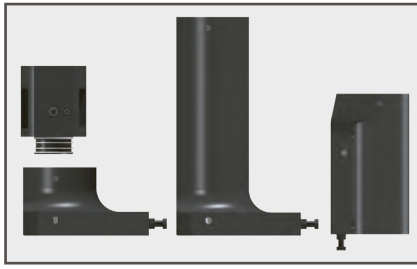

K03 MHD'80

1 B 01
1 B 02
1 B 15
1 MR
1 TU

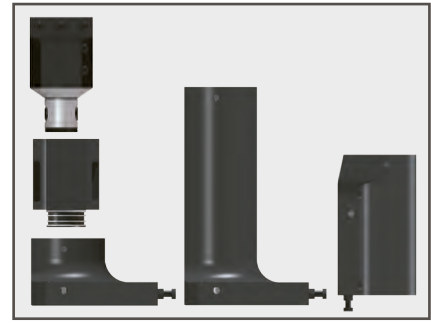

REF.	CODE
KIT K03 PSC 63 UT 3-360 S	501703259501
KIT K03 PSC 63 UT 5-500 / 5-630 / 5-800 S	501705009501
KIT K03 PSC 80 UT 5-500 / 5-630 / 5-800 S	501705009502
KIT K03 PSC 80 UT 8-800 / 8-1000 S	501708009501

REF.	CODE
KIT K03 UT 3-360 S	501703259500
KIT K03 UT 5-500 / 5-630 / 5-800 S	501705009500
KIT K03 UT 8-800 / 8-1000 S	501708009500

TU - MHD'

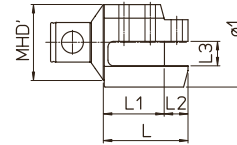

◆ Use with RD 80/ ...

U-TRONIC	REF.	CODE	MHD'	Ø1	L	L1	L2	L3	lb
UT 3 / 5 / 8 ... S ◆	TU 50/60.16	460505016001	50	2.36	2.36	1.73	.63	.63	2.65
UT 3 / 5 / 8 ... S ◆	TU 63/75.20	460506320001	63	2.95	2.95	2.17	.79	.79	8.82
UT 3 / 5 / 8 ... S	TU 80/95.25	460508025001	80	3.74	3.54	2.56	.98	.98	7.94

TP - MHD'

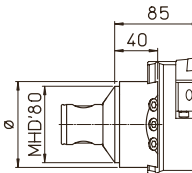

U-TRONIC	REF.	CODE	Ø	lb
UT 3-360 S	TP 80/90.50	460408050001	3.54	5.07
UT 5-500 / 5-630 / 5-800 S	TP 80/90.50	460408050001	3.54	5.07
UT 8-800 / 8-1000 S	TP 80/125.50	460408050002	4.92	7.05

PC

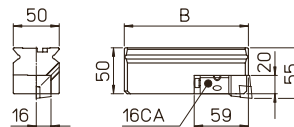

U-TRONIC	REF.	CODE	Ø	lb
UT 3-360 S	PC 11.50	433050160950	3.74	2.87
UT 5-500 / 5-630 / 5-800 S	PC 12.50	433050161350	5.31	4.41
	PC 13.50	433050162000	7.87	7.05
UT 8-800 / 8-1000 S	PC 14.50	433050163000	11.81	11.02

CARTRIDGES 20CA ISO 5611



PTGNL16CA-16

CODE 483010161001

△ TNM1604



PCLNL16CA-12

CODE 483010161002

⊗ CNM1204



PSSNL16CA-12

CODE 483010161003

⊗ SNM1204



PSRNL16CA-12

CODE 483010161004

⊗ SNM1204

TOOLHOLDER WITH AUTOMATIC TOOL CHANGE B50



B50 MECHANICAL



B50 HYDRAULICS

pic.1



U-TRONIC	REF.	U-TRONIC	REF.
UT 3-360 S	- HSK - A63 - A100	UT 3-360 S	- PSC / HSK
UT 5-500 / UT 5-630 / 5-800 S	B50 - DIN69871-B 50	UT 5-500 / UT 5-630 / 5-800 S	B50 - DIN69871
UT 8-800 / 8-1000 S	- MAS BT50	UT 8-800 / 8-1000 S	- MAS BT

Special and HYDRAULICS B50 toolholders for automatic tool change, can be provided on request (pic.1).

U-TRONIC

CHIP REMOVAL CAPACITY

The chip removal rates are indicative for normal working conditions on steels with hardness in the range of 160-200 HB, (average $K_s = 2000 \text{ N/mm}^2$) recommended $V_t 393/525 \text{ sfmm/min}$.

The optimal values and working times must be determined with trials.

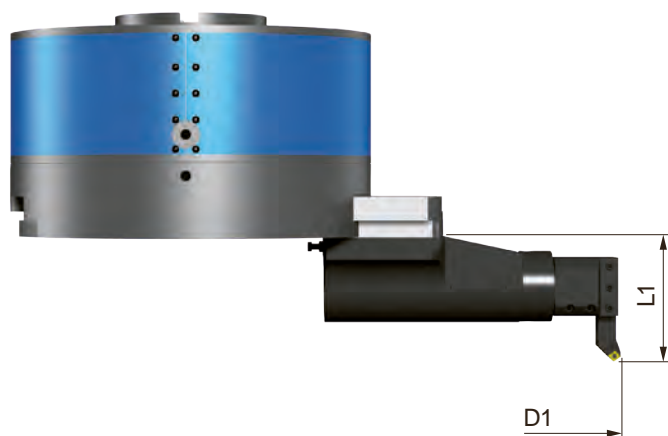
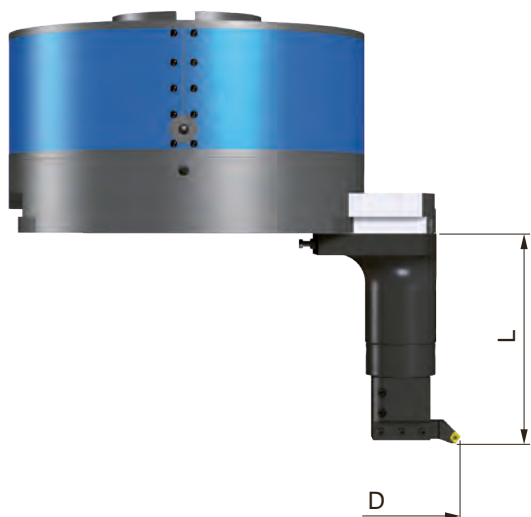

U-TRONIC 3-360 S

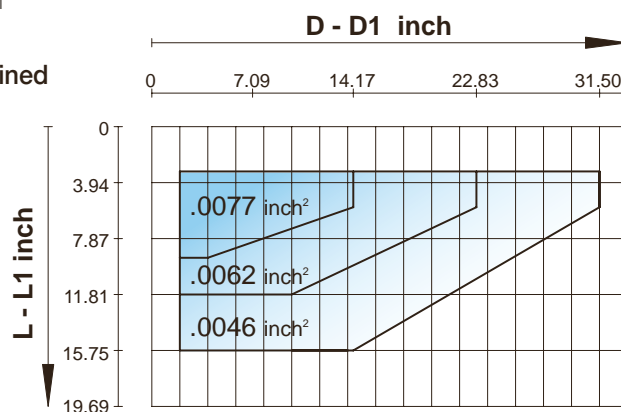

U-TRONIC 5-500 / 5-630 / 5-800 S

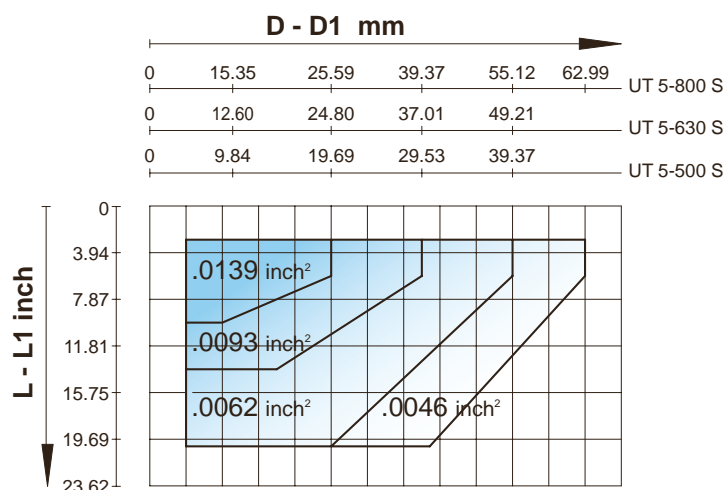

U-TRONIC 8-800 / 8-1000 S

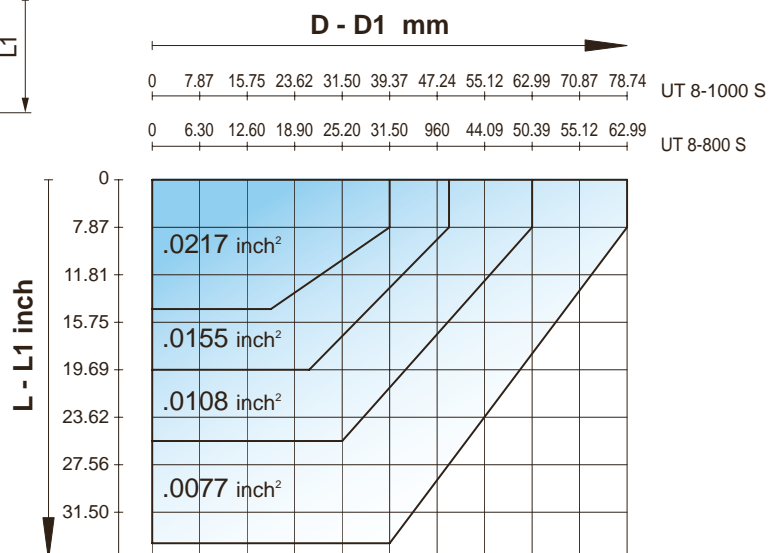

TECHNICAL DATA

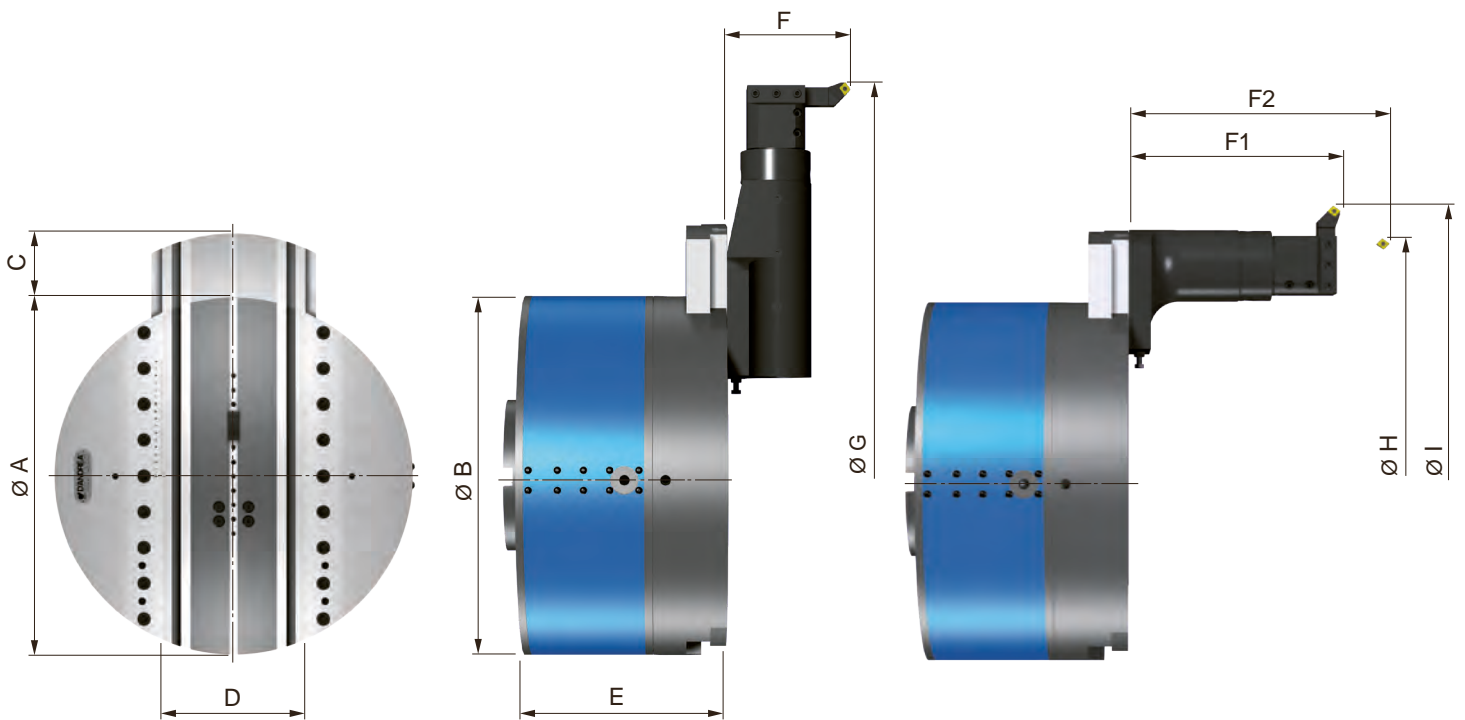

TECHNICAL DATA		UT 3-360 S	UT 5-500 S	UT 5-630 S	UT 5-800 S	UT 8-800 S	UT 8-1000 S
$\varnothing A$	inch	14.17	19.69	24.80	31.50		39.37
$\varnothing B$	inch	14.17	19.69			31.50	
C Radial traverse	inch	4.72	6.30	7.87	9.84	11.02	13.78
D	inch	6.09	7.86		9.06	9.84	10.24
E	inch	9.25	10.96	11.10	14.57	16.14	16.34
$\varnothing G \times F$	inch	31.50 x 5.51	39.37 x 5.91	49.21 x 5.91	62.99 x 5.91	62.99 x 6.30	98.43 x 6.30
$\varnothing H \times F_2$	inch	15.75 x 15.75	22.05 x 21.26	27.56 x 21.26	32.68 x 21.26	33.46 x 33.86	41.34 x 33.86
$\varnothing I \times F_1$	inch	26.38 x 26.38	33.46 x 11.61	41.34 x 11.61	51.18 x 11.61	49.21 x 14.57	62.99 x 14.57
Max. inch/min	inch/min	.04 ÷ 15.75				.04 ÷ 19.69	
Max. \varnothing /min	min-1	500	315	250	200		160
Weight	lb	286.60	507.06	310	1168.45	2204.62	2645.55
Radial force	daN	400	500			1000	
Torque	lb ft.	2960	5920			7400	
Repeatability accuracy	inch	.0001					
Boring accuracy		IT7					
Max chip removal	inch ² C40	.0077	.0139			.0217	
Rapid trasverse	inch/min	15.75				19.69	
Roughness	Ra	0,8 ~ 1,2					

TA-CENTER 2 TA-C2

TA-CENTER 2 Boring and facing heads uniquely designed for machines with automatic tool changers and applicable on all machining centers. The toolholder slide movement is managed by an external U-DRIVE unit attached to the spindle flange.

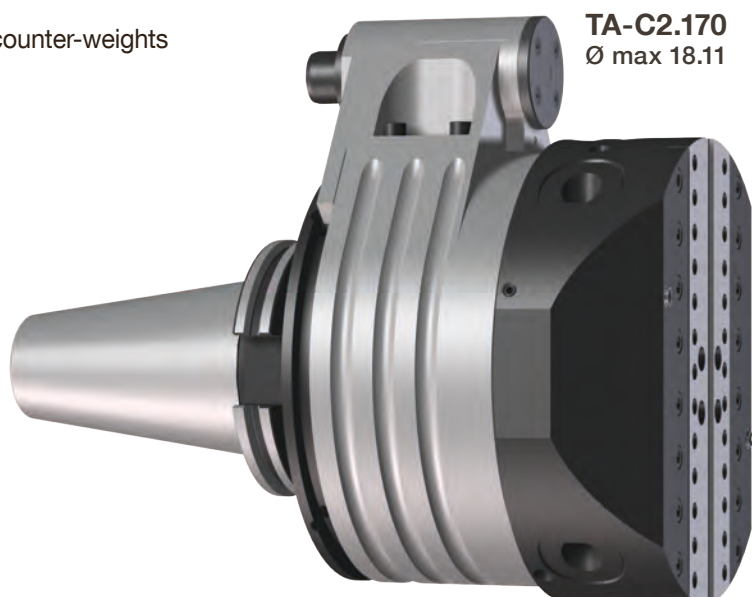
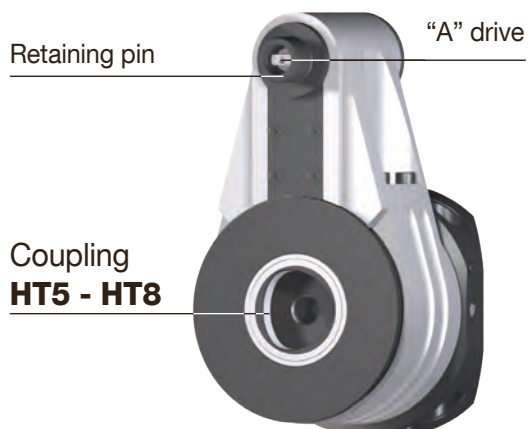
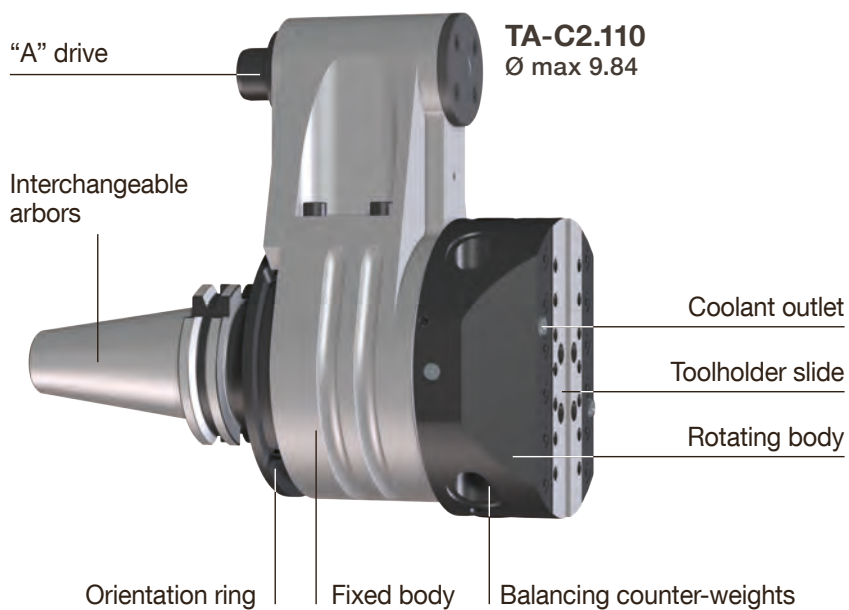
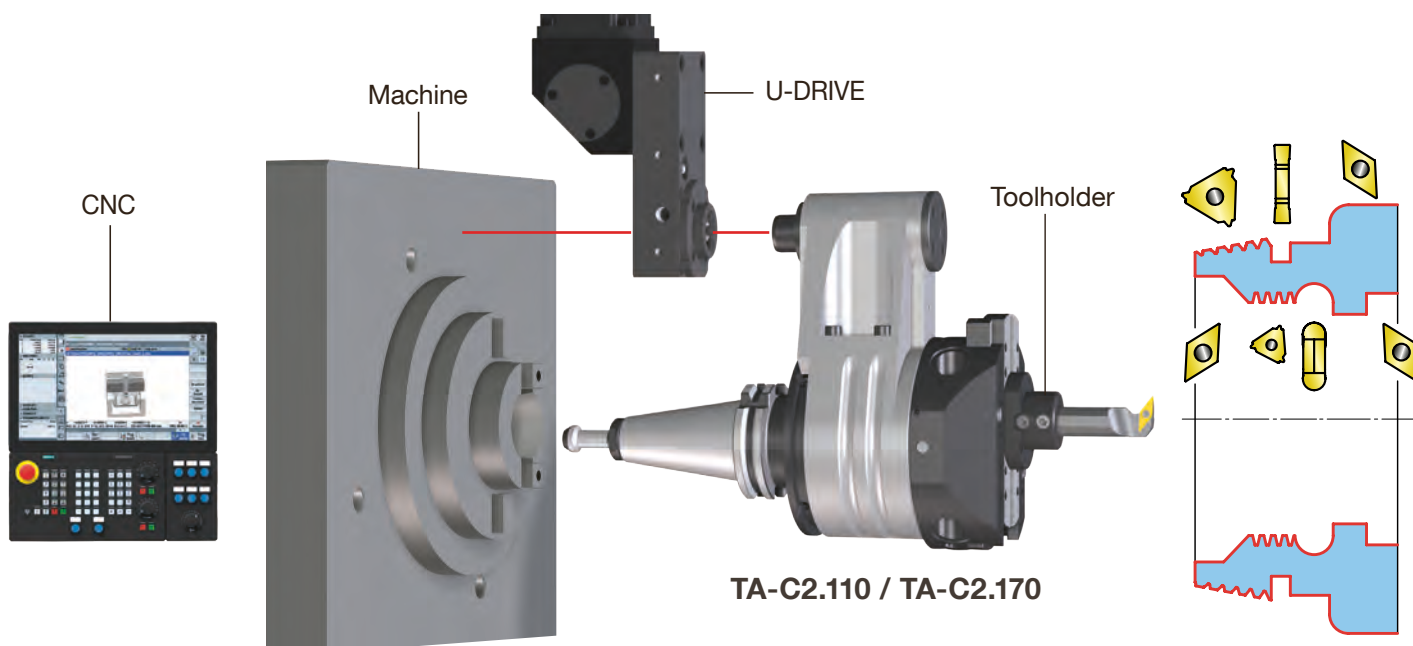

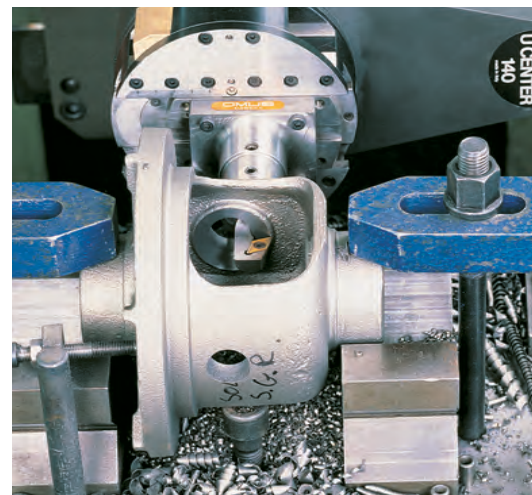
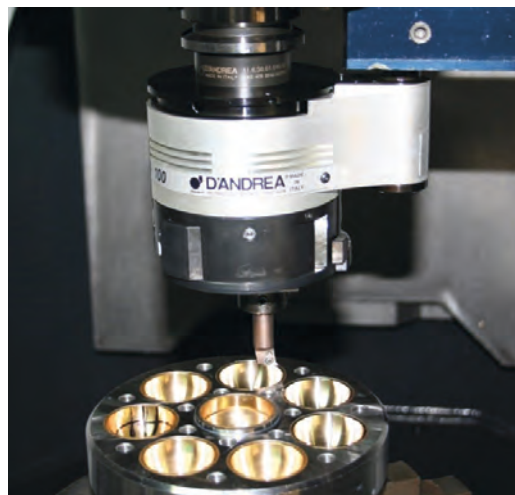
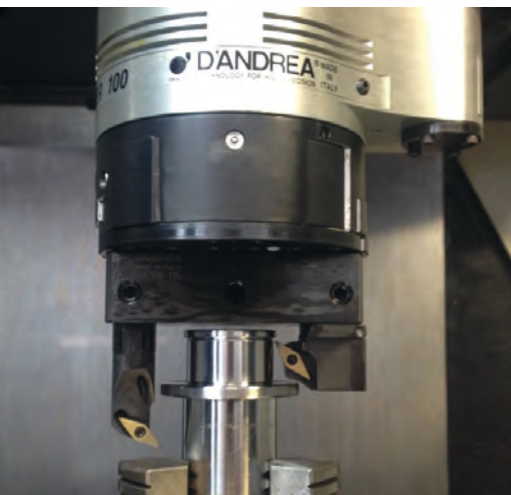
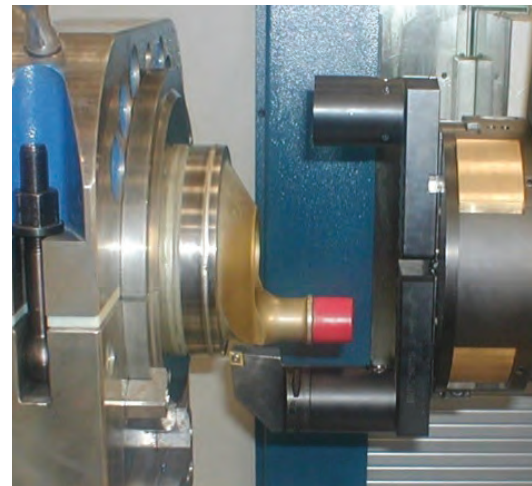
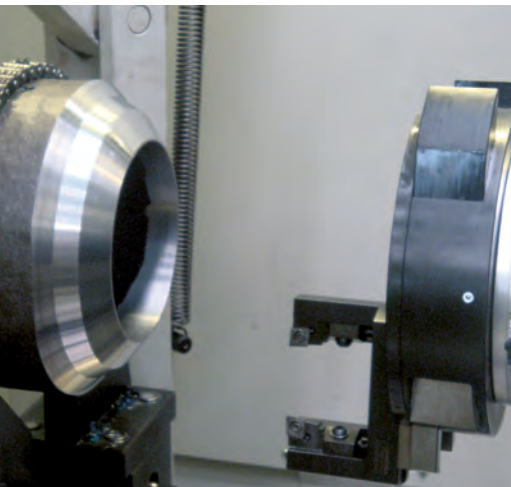
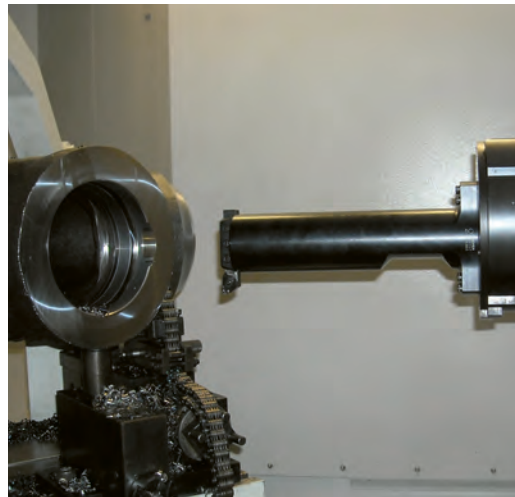

COMMAND



CNC

The TA-CENTER 2 boring and facing heads are designed to be used on machines with automatic tool changers, therefore essentially on all machining centers.

The control of the feed, the tool-holder slide and the tool position, also during rotation, are controlled by a **U-DRIVE** gearbox unit. This group is managed directly by a U-axis of the numerical control of the machining center. A machining center set up in this way offers several additional and different operations including internal and external turning, grooves, taper bores, concave and convex radius machining, cylindrical and conical threads and facing for serration.

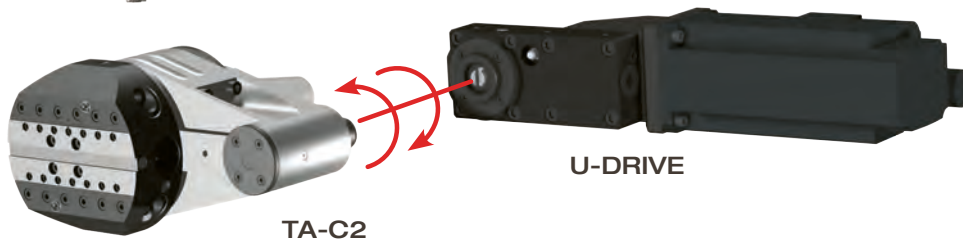

TA-C2

U-DRIVE

COMPONENTS U-DRIVE

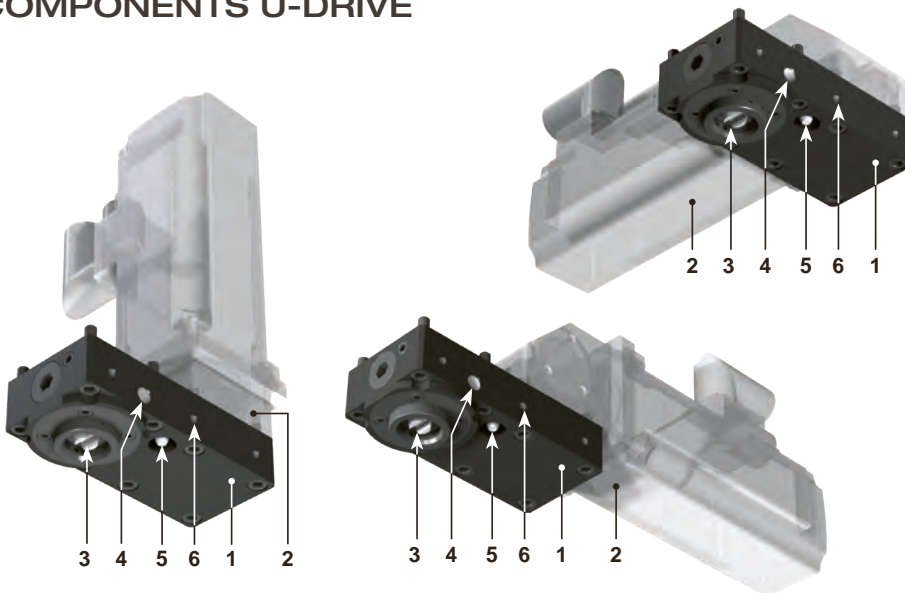

1. Base element
2. Servomotor
3. Mechanical unit for automatic hook-up to the TA-CENTER 2 drive
4. The unit comes with air inlet connection for cleaning the drive
5. Manual lubrication
6. n°6 M5x.31 holes to be used for securing a possible protective casing

PREARRANGEMENTS

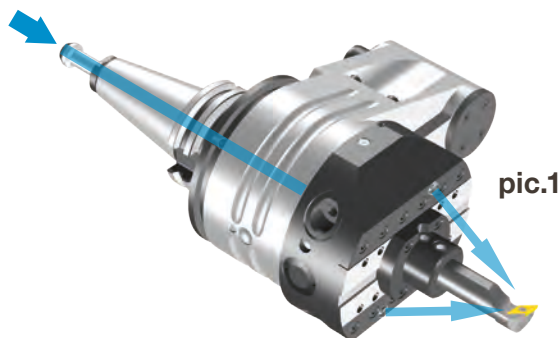

pic.1

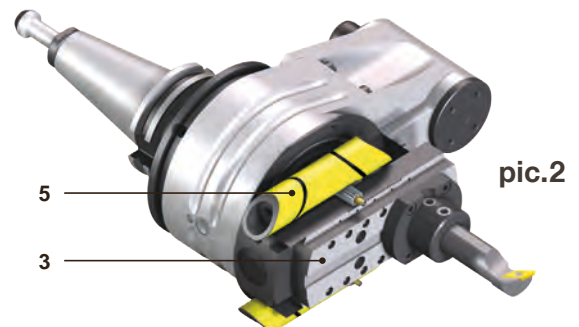

pic.2

Coolant supply pic.1

Coolant exits from the two adjustable nozzles in the TA-C2 located next to the slide after crossing the taper and the rotating body of the head. This noteworthy advantage ensures longer duration of the cutting edge, quicker cutting speed and for obtaining good surface finishes. The centralized supply of coolant does not harm the TA-C2 of which the internal labyrinth protected by an O-ring. It is advisable to not exceed **725 PSI** of pressure.

Balancing pic.2

TA-CENTER heads are designed with two counterweights (**5**) for automatic balancing, that move opposite to the slide (**3**) allowing to machine at a higher number of rpm without noticeable oscillations.

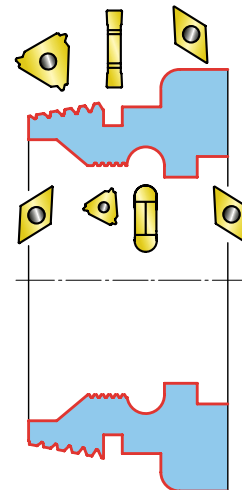
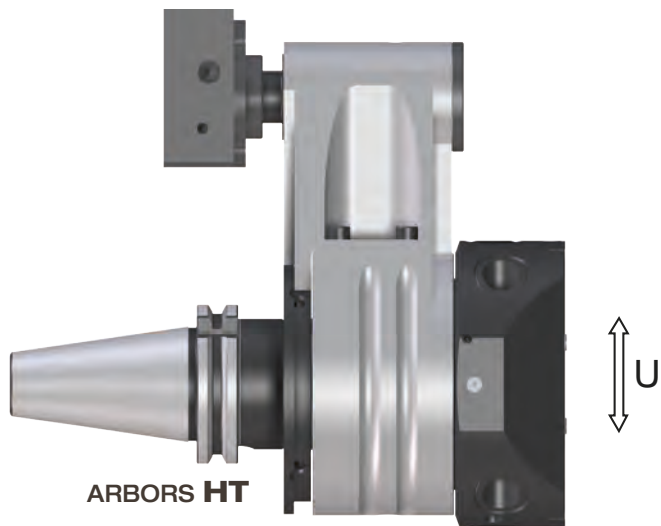

The chip removal rates are indicative for normal working conditions on steels with hardness in the range of 160-200 HB, (average Ks = 2000 N/mm²) recommended Vt 393/525 sfmm/min.

The optimal values and working times must be determined with trials.

CHIP REMOVAL CAPACITY
TA-C2 / TA-T2

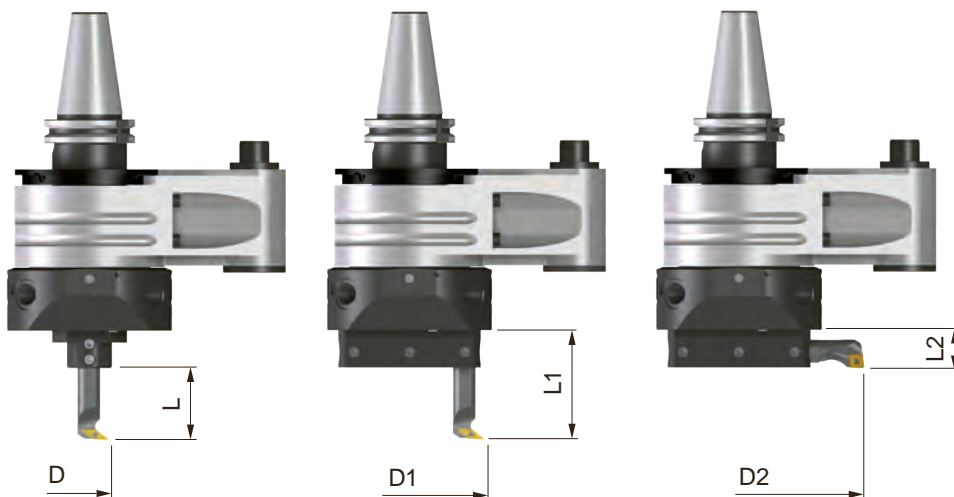

	TA-C2.110 TA-T2.110	TA-C2.170 TA-T2.170
D	.39 ~ 4.02	.79 ~ 7.64
L	2.56	3.94
D1	3.78 ~ 4.96	6.02 ~ 10.35
L1	3.54	5.51
D2	4.96 ~ 9.84	7.99 ~ 18.11
L2	1.00	1.52

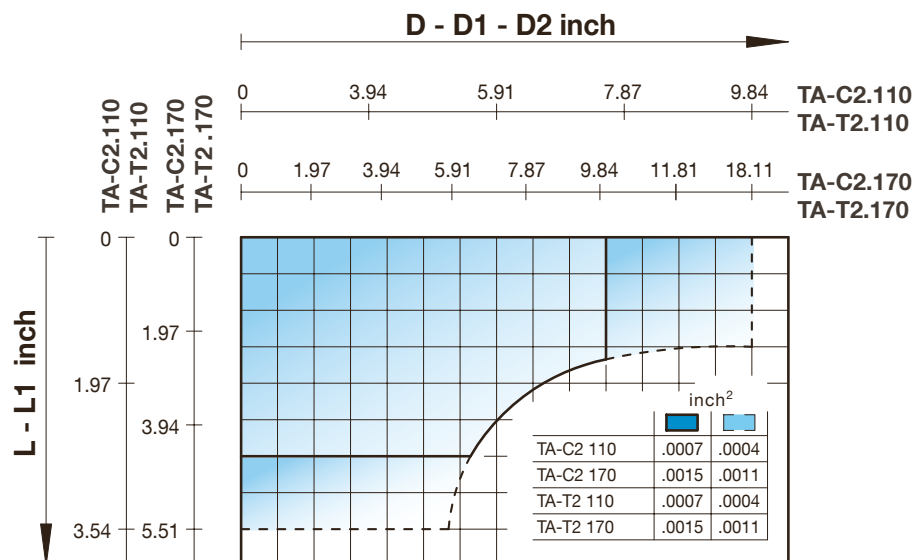

TA-CENTER 2

K02



REF.	CODE		
K02 TA-C2.110 I.80 R. 0.25	501251100800		
K02 TA-C2.110 I.80 R. 0.5	501251100801		
K02 TA-C2.110 I.110 R. 0.25	501251101100		
K02 TA-C2.110 I.110 R. 0.5	501251101101		
K02 TA-C2.170 I.110 R. 0.25	501251701100		
K02 TA-C2.170 I.110 R. 0.5	501251701101		
U-DRIVE KB1-KA1			

For Interchangeability with previous version TA-CENTER, use **TA-C2** with mechanical ratio **R .02**

ARBORS HT TA-C2 / TA-T2

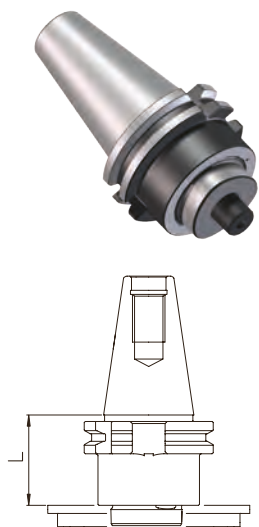

	REF.		CODE	L	lb		
TA-C2.110 TA-T2.110	DIN69871-AD40 HT5 .36.5	41HT05024000	1.44	2.43			
	DIN69871-AD40 HT5 .44.5	41HT05024001	1.75	2.65			
	DIN69871-AD50 HT5 .36.5	41HT05025000	1.44	6.17			
	MAS403BT-AD40 HT5 .27	41HT05034000	1.06	2.20			
	MAS403BT-AD40 HT5 .36.5	41HT05034001	1.44	2.43			
	MAS403BT-AD40 HT5 .44.5	41HT05034002	1.75	2.65			
	MAS403BT-AD50 HT5 .54.5	41HT05035000	2.15	8.16			
	HSK-A63 HT5 .54.5	41HT05046300	2.15	2.43			
	HSK-100 HT5 .60.5	41HT05041000	2.38	6.17			
	CAT40 UNC HT5 .54.5	41HT05054000	2.15	2.87			
CAT50 UNC HT5 .36.5	41HT05055000	1.44	6.17				
TA-C2.170 TA-T2.170	DIN69871-AD50 HT8 .36.5	41HT08025000	1.44	7.50			
	MAS403BT-AD50 HT8 .38.5	41HT08035000	1.52	8.16			
	HSK-A100 HT8 .76.5	41HT08041000	3.01	8.82			
	CAT50 UNC HT8 .50.5	41HT08055000	1.99	8.60			

P120 TA-C2 / TA-T2

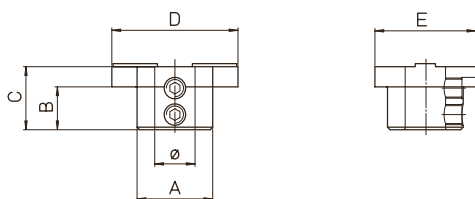

REF.	CODE	ØH7	A	B	C	D	E	lb		
P 120 TA-C2.110 / TA-T2.110	431550160250	.63	1.18	.67	.98	1.97	1.57	.44		
P 120 TA-C2.170 / TA-T2.170	431550250380	.98	1.85	1.08	1.50	2.99	2.13	1.21		

P130 TA-C2 / TA-T2

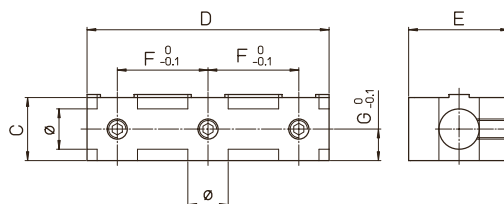

REF.	CODE	ØH7	C	D	E	F	G	lb		
P 130 TA-C2.110 / TA-T2.110	433040250950	.63	.98	3.74	1.57	1.46	.41	1.10		
P 130 TA-C2.170 / TA-T2.170	433054381520	.98	1.50	5.98	2.13	2.34	.65	3.53		

TECHNICAL DATA

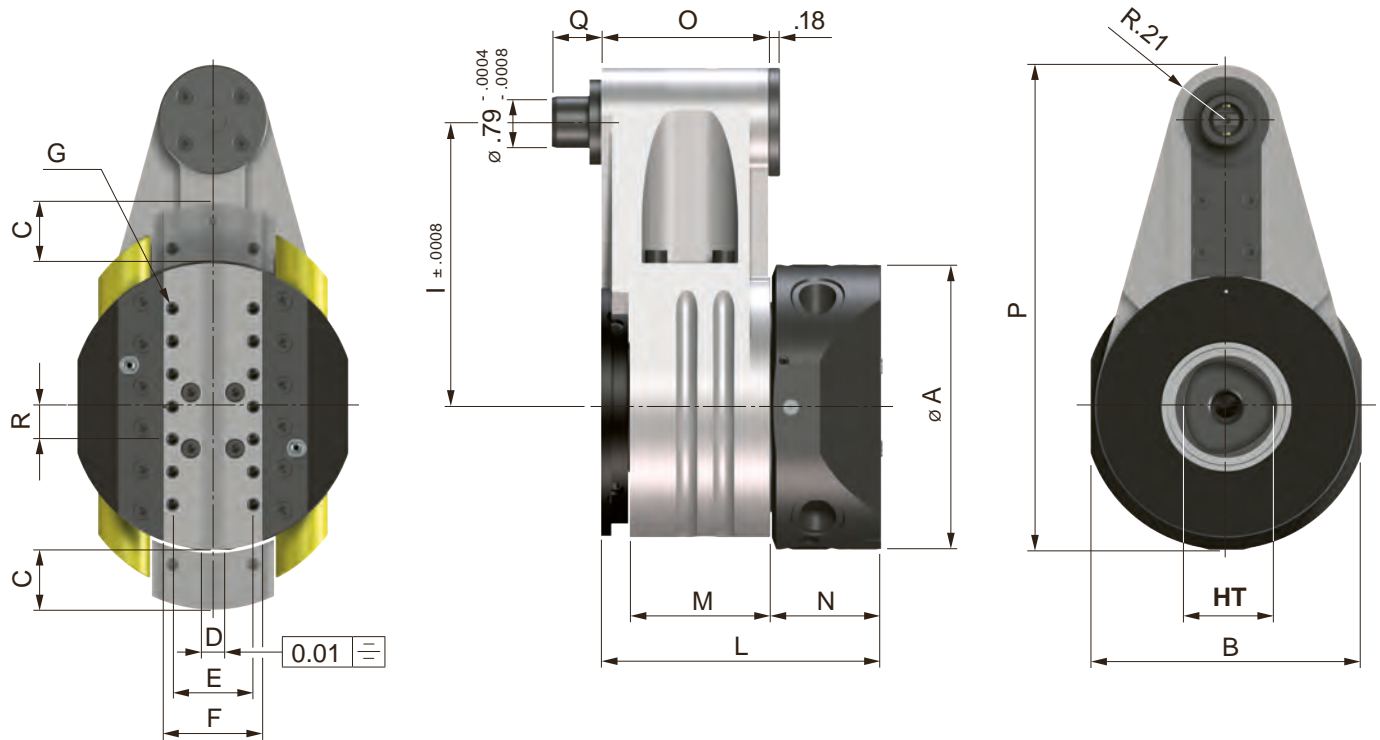

TECHNICAL DATA		TA-C2.110	TA-C2.170
∅ A	inch	4.33	6.69
B	inch	4.09	6.46
C radial traverse	inch	± .59	± 1.18
D	inch	.31 ^{+.002} _{+.0008}	.39 ^{+.002} _{+.0008}
E	inch	1.22	1.57
F	inch	1.50	2.13
G	inch	M 4	M5
HT		HT5	HT8
I	inch	3.15 / 4.33	4.33
L	inch	4.25	5.35
M	inch	2.17	2.72
N	inch	1.65	2.20
O	inch	2.54	2.72
P	inch	6.14 / 7.32	8.50
Q	inch	.75	.75
R	inch	.49	.49
Feed	inch/min	.04 ÷ 16.69	
Radial force	daN	150	250
Maximum speed	min ⁻¹	2000	1600
Torque	lb ft.	2960	5920
Weight without the cone	lb	12.57	36.38
Boring accuracy		IT7	
Max workable ∅	inch	9.84	18.11
Max chip removal on C40 steel	inch ²	.0008	.0015
Roughness	Ra	0.8 - 1.2	

TA-TRONIC 2 TA-T2

TA-TRONIC 2 Boring and facing heads designed to be applied manually on small boring machines, machining centers and special machines. The integrated servomotor, connected to the CN, manages the toolholder slide movement. The stationary body is held in position by a flange or, for light operations, by a simple anti-rotation pin.

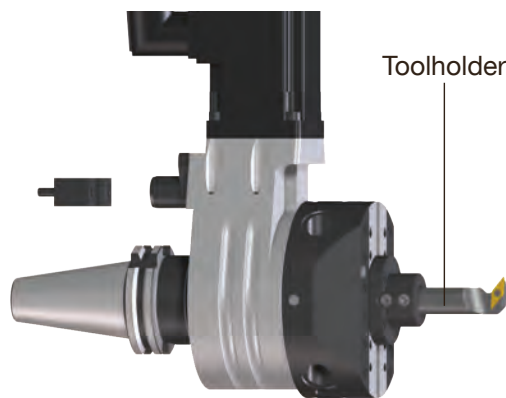
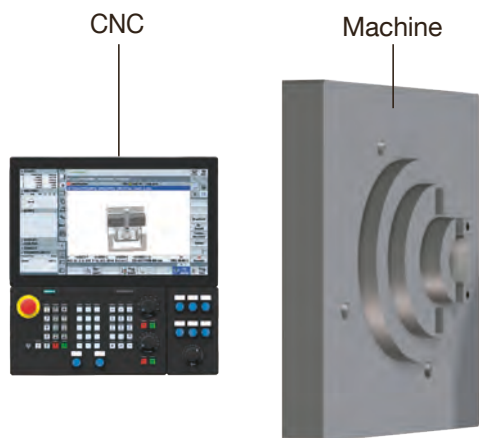

TA-T2.110 / TA-T2.170

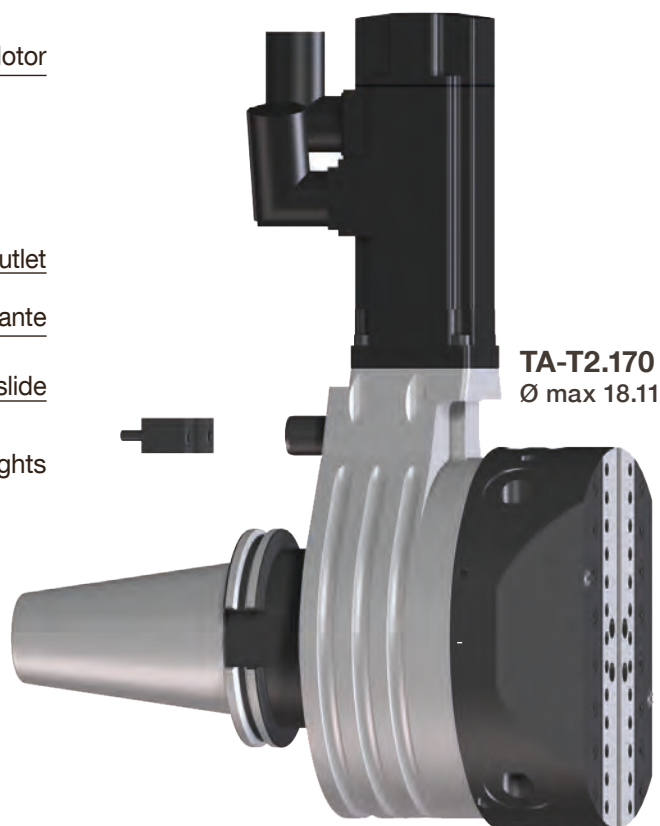
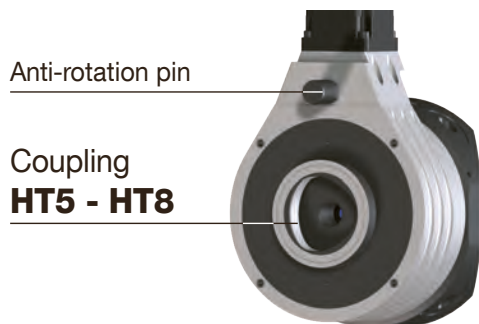
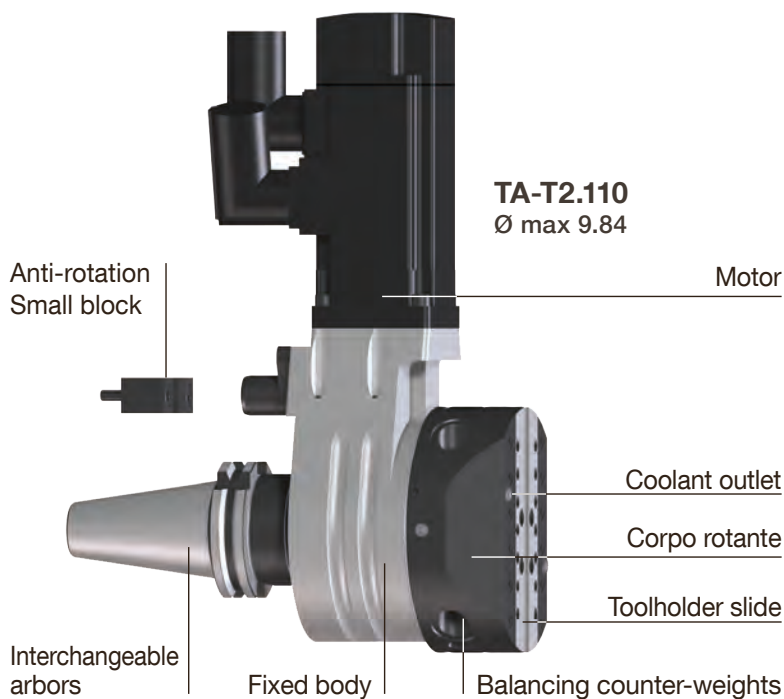
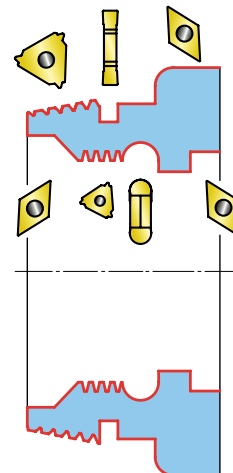

COMMAND



CNC

The control of the TA-T2 heads takes place through the direct connection to the "U" axis of the numerical control of the machine tool that allows boring, internal, external and back facing, internal and external turning, grooves, facing for serration, threads and taper bores, as well as concave and convex radius machining through interpolation with the other axes.

Coolant supply pic.1

In the TA-T2, coolant exits from the two adjustable nozzles are located next to the slide after crossing the taper and the rotating body of the head. This noteworthy advantage ensures longer duration of the cutting edge, quicker

cutting speed and for obtaining good surface finishes. The centralized supply of coolant does not harm the TA-T2 of which the internal labyrinth protected by an O-ring. It is advisable not to exceed **50 BAR** of pressure.

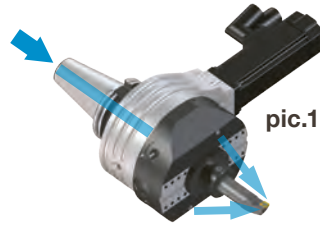

Balancing pic.2

TA-TRONIC heads are designed with two counter-weights (5) for automatic balancing, that move opposite to the slide (3) allowing to machine at a higher number of rpms without noticeable oscillations.

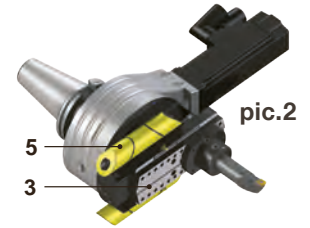

PREARRANGEMENTS

K02

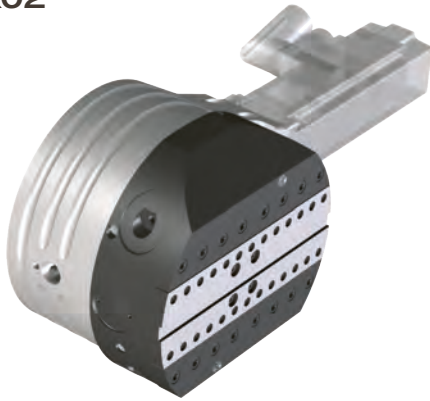

ARBORS HT / P120 - P130 p.70



CHIP REMOVAL p.69

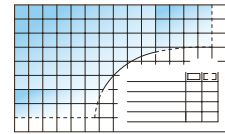

REF.	CODE		
K02 TA-T2.110 1FK7022-5AK74-1HA5	501201100400		
K02 TA-T2.110 FANUC βis 1/6000	501201100800		
K02 TA-T2.170 1FK7032-2AK74-1EA2	501201700400		
K02 TA-T2.170 FANUC βis 1/6000	501201700800		
FLANGIA TA-T2.110 / TA-T2.170			

TECHNICAL DATA

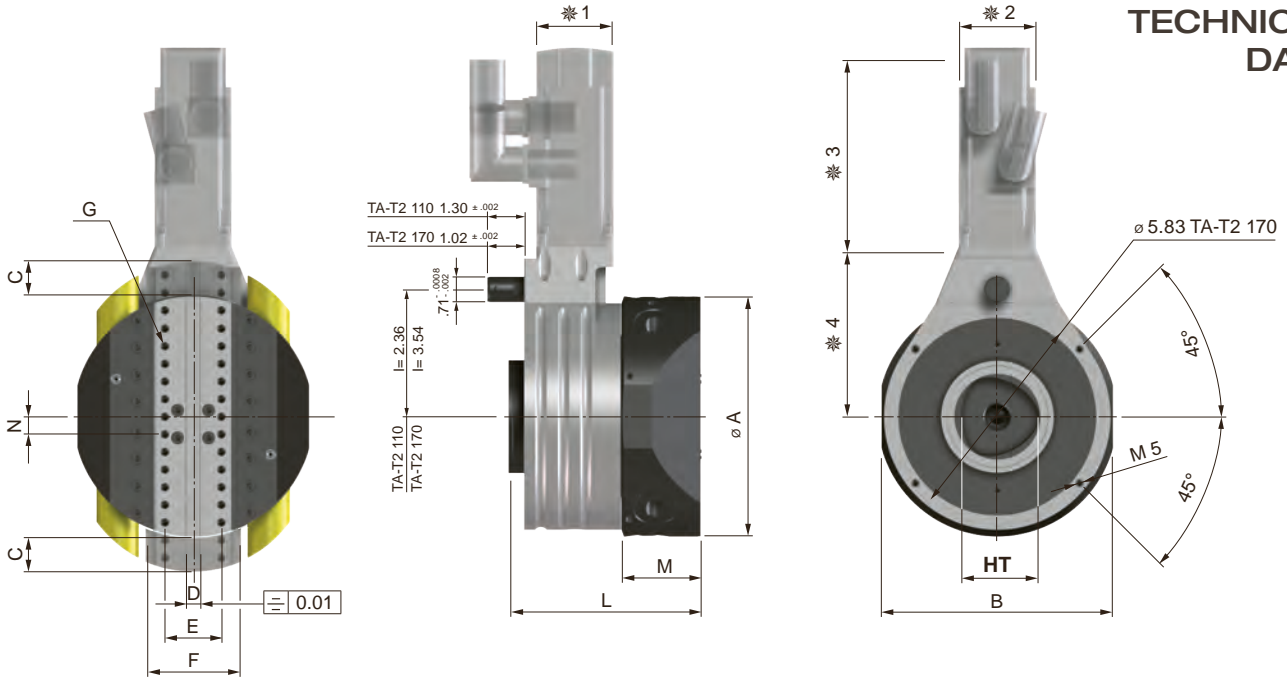

TECHNICAL DATA	TA-T2.110	TA-T2.170
Ø A	inch 4.33	inch 6.69
B	inch 4.09	inch 6.46
C radial traverse	inch ± .59	inch ± 1.18
D	inch .31 ^{+0.002} / _{+0.0008}	inch .39 ^{+0.002} / _{+0.0008}
E	inch 1.22	inch 1.57
F	inch 1.50	inch 2.13
G	inch M4	inch M5
HT	5	8
L	inch 4.25	inch 5.35
M	inch 1.65	inch 2.20
N	inch 12.5	
Feed	inch/min .04 ÷ 19.69	
Radial force	daN 150	daN 250
Maximum speed	min-1 2000	min-1 1600

TECHNICAL DATA	TA-T2.110	TA-T2.170
Torque	lb ft. 2960	lb ft. 5920
Weight without the cone	lb ft. 11.68 without motor	lb ft. 34.83 without motor
Boring accuracy	IT7	
Max workable ø	inch 9.84	inch 18.11
Max chip removal on C40 steel	inch ² .0011	inch ² .0015
Roughness	Ra 0.8 - 1.2	
SIEMENS Motors Dimensions	Siemens 1FK7022	Siemens 1FK7032
* 1	2.17	2.83
* 2	2.17	2.83
* 3	7.01	6.81
* 4	3.54	4.72
FANUC Motors Dimensions	FANUC βis 1/6000	
* 1	2.36	
* 2	2.36	
* 3	4.39	
* 4	3.54/4.72	

* Rough measures that may vary on changing the motor

AUTORADIAL

AUTORADIAL Automatic facing heads that can be applied on machining centers and on NC machines without the need for an electronic interface or interlock. They perform automatic working cycle without ever stopping the rotation of the spindle. Particularly suitable for machining of seats for elastic rings, facing for serration and creating “phonographic” spirals.



K02



SPECIAL
AUTORADIALS
ON REQUEST

REF.	Finch/∅	K02 AR 125 CODE	K02 AR 160 CODE
K02 AR...-F. .002 ± .0002	.002	500612520050	500616020050
K02 AR...-F. .004 ± .0002	.004	500612520100	500616020100
K02 AR...-F. .008 ± .0004	.008	500612520200	500616020200
K02 AR...-F. .012 ± .0004	.012	500612520300	500616020300
K02 AR...-F. .016 ± .0008	.016	500612520400	500616020400
K02 AR...-F. .020 ± .0008	.020	500612520500	500616020500
K02 AR...-F. .024 ± .0008	.024	500612520600	500616020600

K-NC

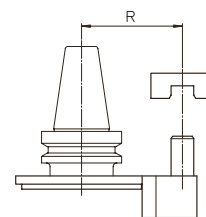

REF.	R.80 CODE	R.110 CODE
K-NC R...-AR125	394112508002	394112511002
K-NC R...-AR160	394116008002	394116011003

P110

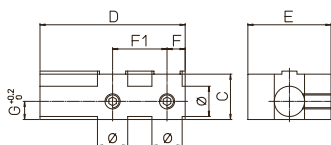
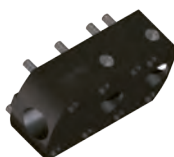

REF.	CODE	∅H7	C	D	E	F	F1	G	lb
AR 125 - P 110	433056381200	.98	1.54	4.76	2.20	.59	1.79	.63	2.87
AR 160 - P 110	433063481600	1.26	1.93	6.46	2.48	.75	2.48	.83	5.51



REF.	MHD' Complete range of arbors on page 8
AR 125	63
AR 160	80

REF.	Finch/∅	K02 AR 125 CODE	K02 AR 160 CODE
F .002-AR... ± .0002	.002	382006105001	382006205001
F .004 - AR... ± .0002	.004	382006110001	382006210001
F .008 - AR... ± .0004	.008	382006120001	382006220001
F .012 - AR... ± .0004	.012	382006130001	382006230001
F .016 - AR... ± .0008	.016	382006140001	382006240001
F .020 - AR... ± .0008	.020	382006150001	382006250001
F .024 - AR... ± .0008	.024	382006160001	382006260001

CHIP REMOVAL CAPACITY - MAX ROTATION SPEED

The chip removal rates are indicative for normal working conditions on steels with hardness in the range of 160-200 HB, (average Ks = 2000 N/mm²) recommended Vt 393/525 sfmm/min.

The optimal values and working times must be determined with trials.

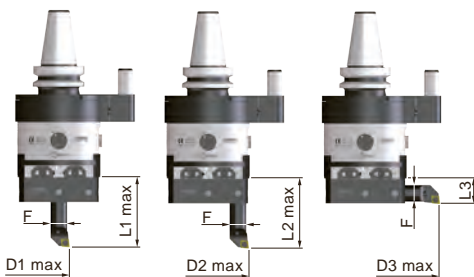

	AR 125	AR 160
F	.98	1.26
D1 max	3.90	5.67
L1	6.30	7.87
D2 max	7.48	10.63
L2	6.30	7.87
D3 max	12.60	15.75
L3	1.57	1.97

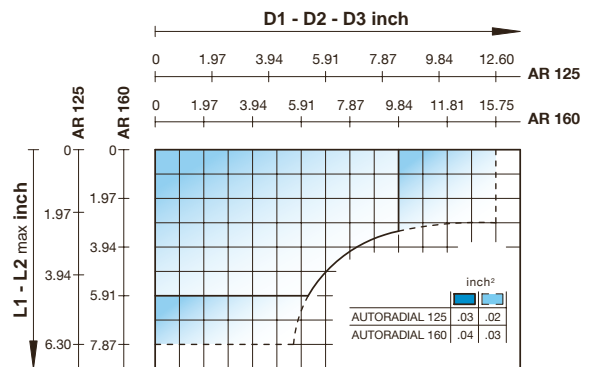

TECHNICAL DATA

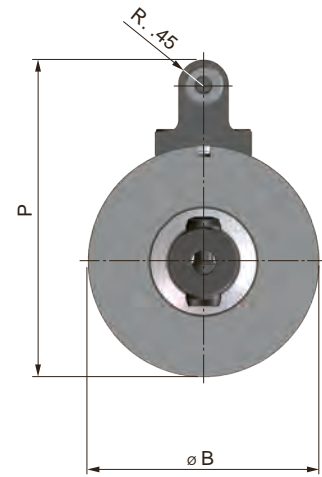
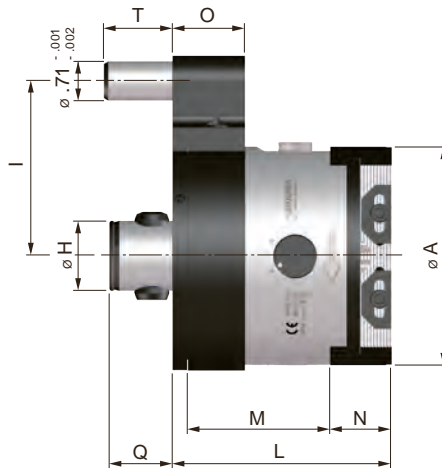
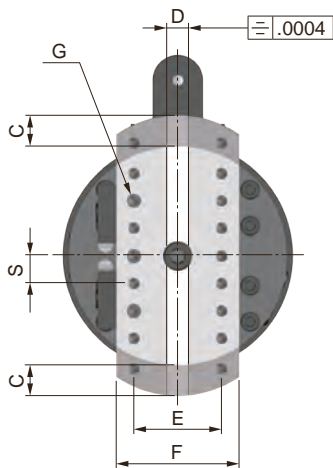

TECHNICAL DATA		AR 125	AR 160
∅ A	inch	4.92	6.30
∅ B	inch	5.12	5.12
C radial traverse	inch	± .79	± 1.38
D	inch	.39 ^{+ .001} ₀	.47 ^{+ .001} ₀
E	inch	1.57	1.97
F	inch	2.48 ^{- .0001} _{- .0003}	3.15 ^{- .0001} _{- .0003}
G	inch	M5	M6
∅ H	inch	(MHD'63) 1.65 ^{- .0002} _{- .0003}	(MHD'63) 1.65 ^{- .0002} _{- .0003}
I	inch	3.15/4.33	3.15/4.33
L	inch	4.33	4.92

TECHNICAL DATA		AR 125	AR 160
M	inch	2.95	3.27
N	inch	1.10	1.38
O	inch	1.38	1.38
P	inch	6.16 / 7.34	6.75 / 7.93
Q	inch	1.52	1.75
S	inch	.49	.59
T	inch	1.56	1.79
Maximum speed	min-1	500	400
Weight without the cone	lb	19.84	30.86
Quick return	inch/∅	.03	.03

TA-SENSITIV 2 TA-S2

FACING AND BORING HEADS

TA-SENSITIV 2 - Boring and facing heads, applicable for milling machines, boring mills and radial drills with the possibility of manual adjustments during **machine stops** and automatic feeds during the revolution of the machine spindle.

It's possible to carry out external and internal facing operations, backward operations, cylindrical and conical borings, internal and external grooves, turning and chamfers.

The arbor is interchangeable and, thanks to the MHD' coupling, it allows the use of all available arbors from the MHD' modular system.

TA-S2.120 max Ø 9.84 **TA-S2.170** max Ø 15.75

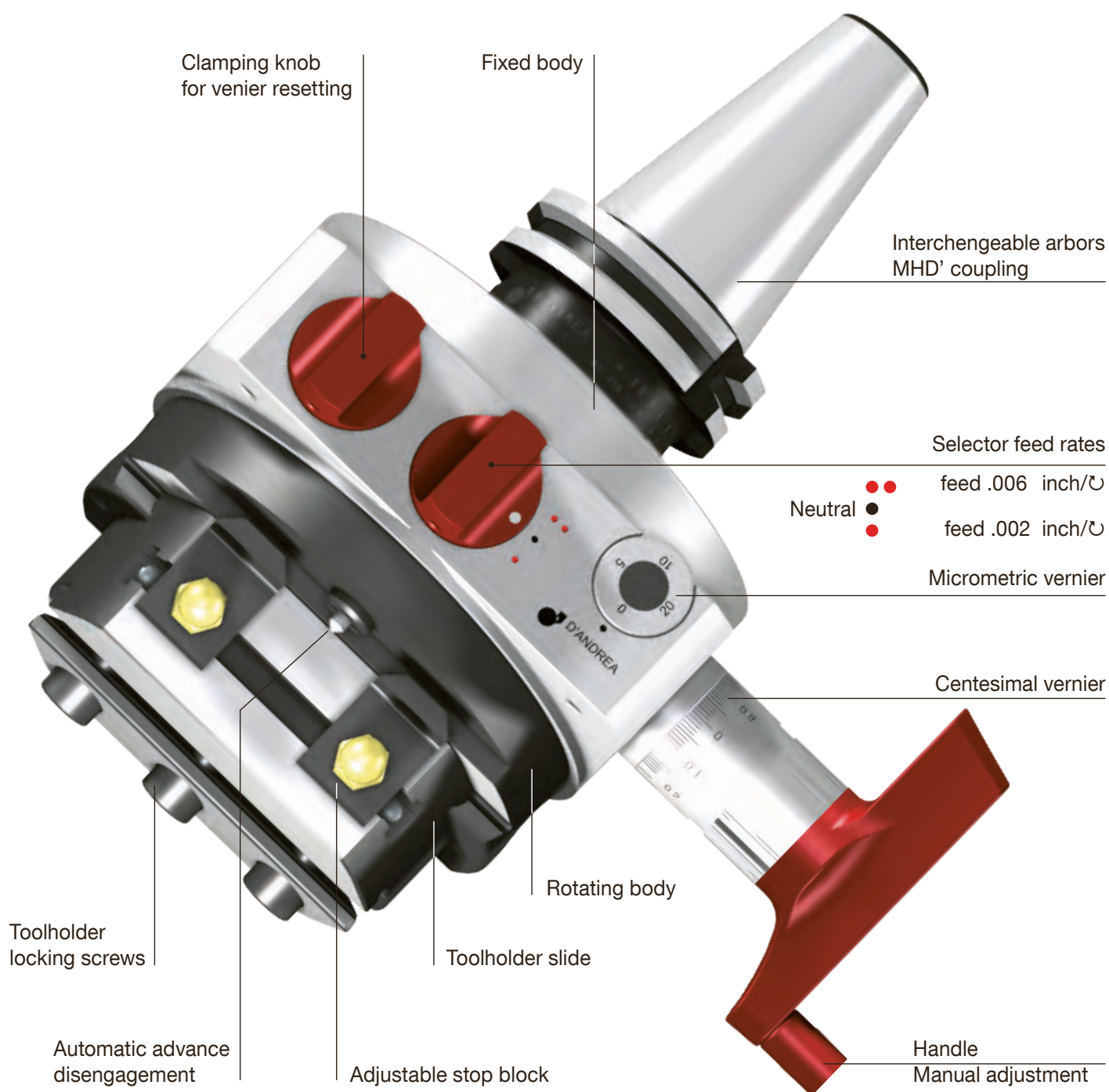

APPLICATION

The TA-S2 heads can be applied to the machine tools through the driving arbor (1) and an anti-rotation stop block (2). For heavy machining it is recommended to apply a flange.

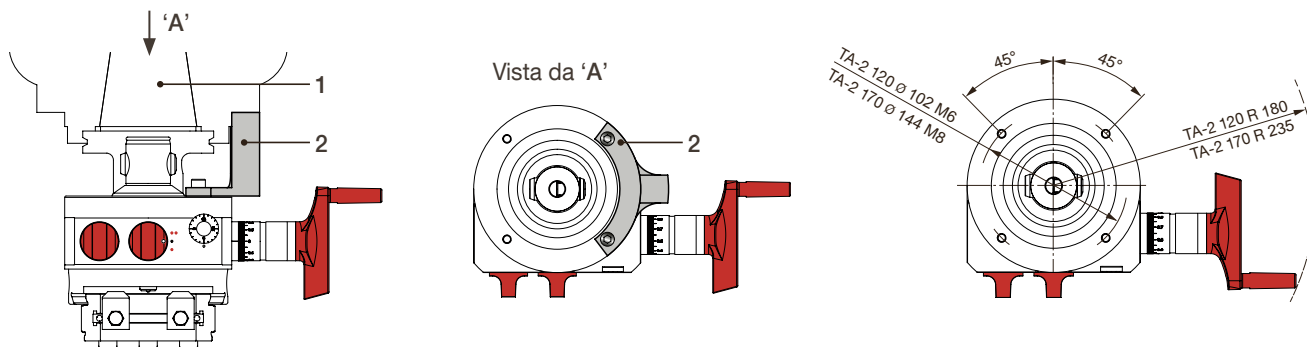

TECHNICAL DATA

TA-S2.120	TECHNICAL DATA		TA-S2.170
9.84	Max workable \varnothing	inch	15.75
1.57	C radial traverse	inch	2.36
1000	Maximum speed	mm-1	800
14.33	Net weight	lb	41.89
295.02	Torque	ft.lb	590.05
2 - 6	Motor Power	Kw	3.5 - 11

REF.	CODE	lb	
K02 TA-S2.120	500212031001	12.79	
P95 TA-S2.120	433030300951	0.88	
K02 TA-S2.170	500217031001	30.86	
P140 TA-S2.170	433040401401	1.76	

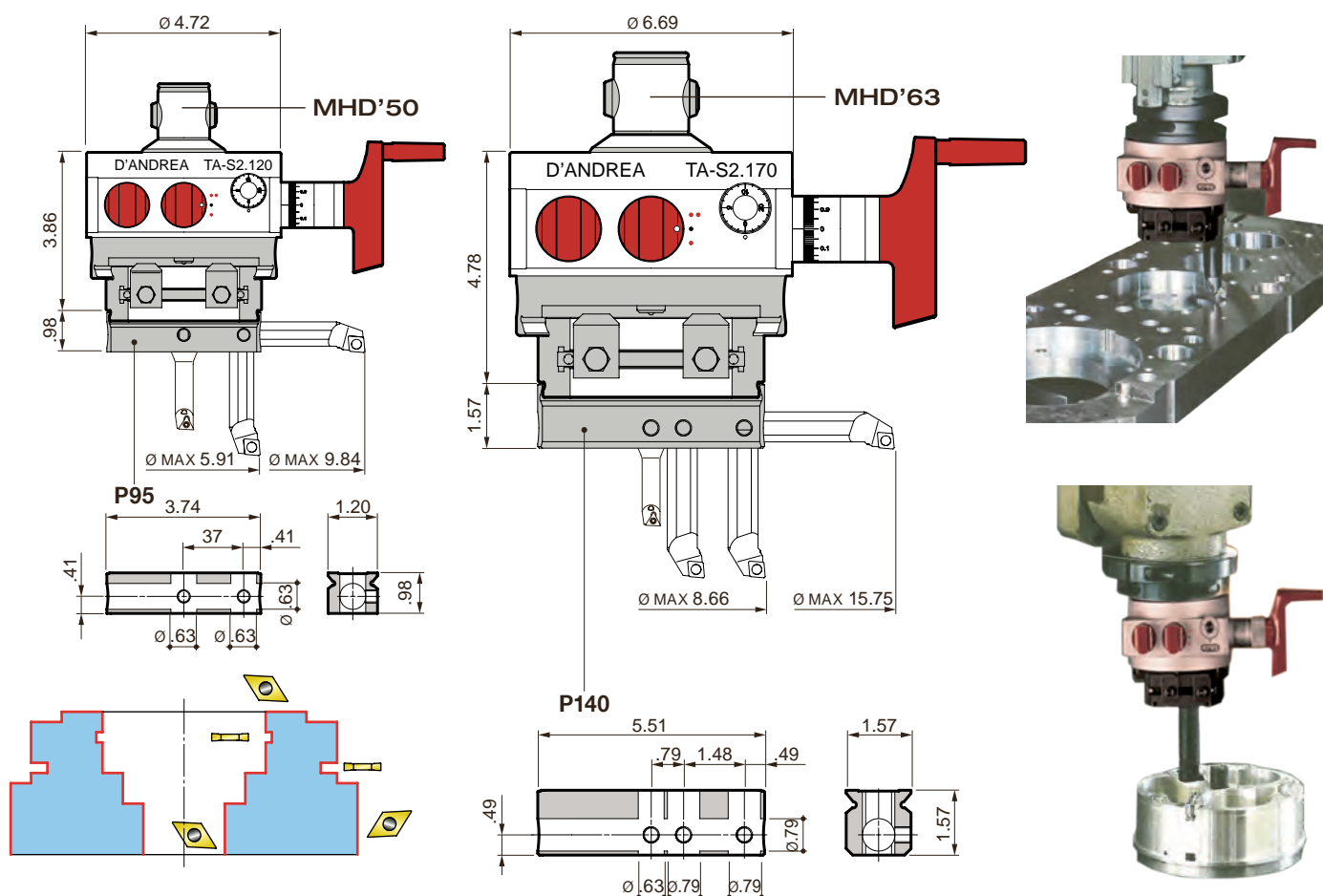

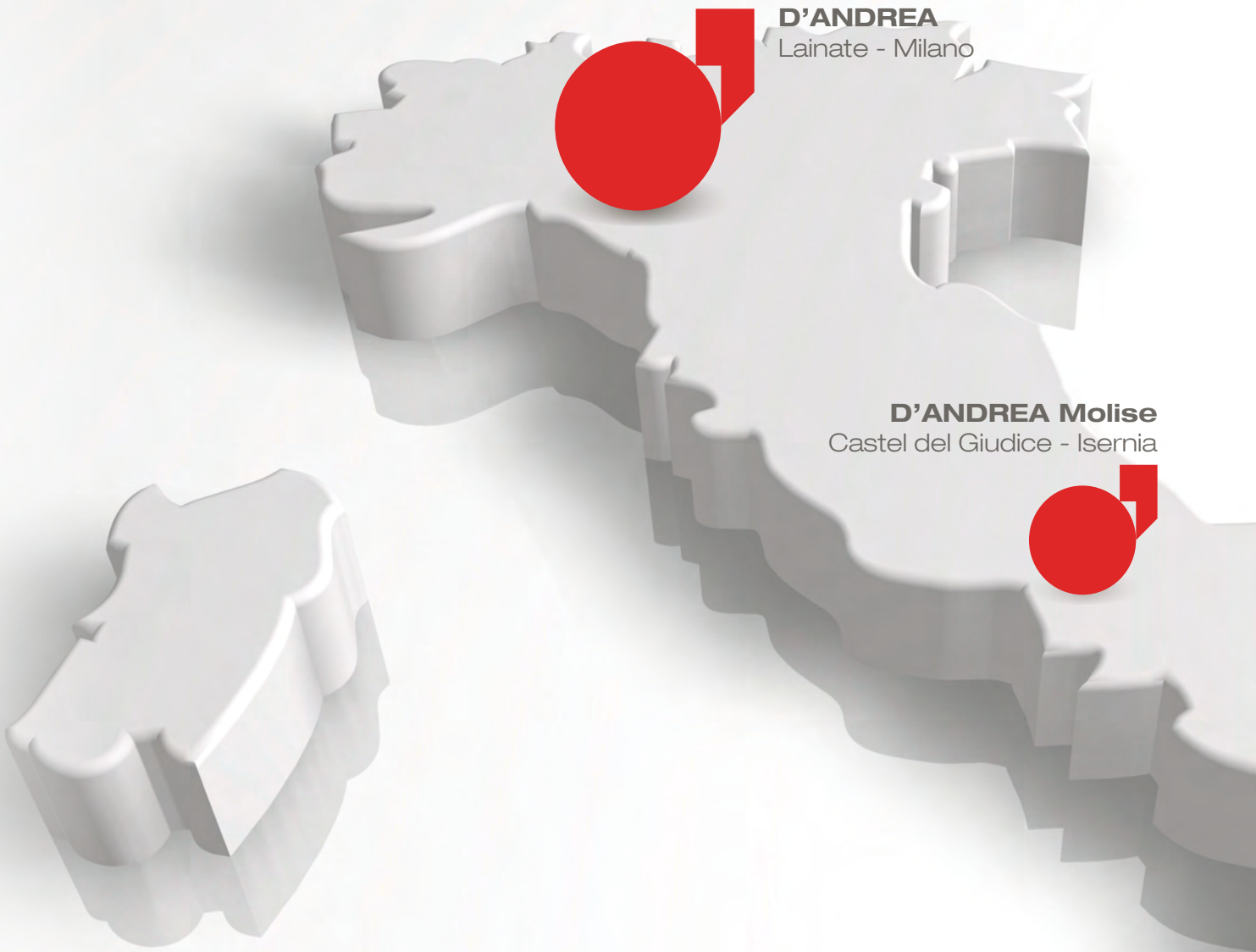

D'ANDREA
Lainate - Milano

D'ANDREA Molise
Castel del Giudice - Isernia

made in italy



You will be welcome in Italy
Wir warten auf euch in Italien
Os esperamos en Italia
Nous vous attendons en Italie
Vi aspettiamo in Italia

Enrico D'Andrea



D'ANDREA IN ITALY AND WORLDWIDE



© D'ANDREA s.p.a.

Via Garbagnate 71 • 20045 Lainate (MI) Italy
Tel. +39 02 937532.1 • Fax +39 02 93753240
www.dandrea.com • info@dandrea.com

The technical data shown in this catalogue are not binding and they can be modified also without notice.



D'ANDREA[®]
TECHNOLOGY FOR HIGH PRECISION

Via Garbagnate, 71
20045 Lainate (MI) Italy

t. +39 02.937532.1
f. +39 02.93753240

info@dandrea.com
www.dandrea.com

TYSON TOOL[®]

75 Ormont Drive, Toronto, ON. M9L 2S3
TEL: 416.746.3688 • FAX: 416.746.5415
sales@tysontool.com • www.tysontool.com

