

## Ranger™ Face Grooving

MTC™  
Cutoff & Grooving

Separator®  
Cutoff

Chipmaker®  
O.D. & I.D. Grooving

Ranger™  
Face Grooving

Octicut®  
Threading

# Table Of Contents



Manchester Insert Carbide Grades .....4

MTC™ System .....A1—A21

- MTC-PT™ & MTC-PTN™ Inserts
- MTC-PC™ & MTC-PCN™ Inserts
- MTC™ Toolholder System for Swiss Style CNC Machines
- MTC™ Integrated Shank Toolholder System
- MTC™ SLS™ Cutoff/Parting Toolholder System
- MTC™ Face Grooving Integral Shank System
- MTC™ SLS™ Face Grooving System
- MTC™ SLS™ O.D. Grooving/Profiling System
- MTC™ SLS™ I.D. Grooving System
- MTC™ Conversion Components
- Application Guidelines



Separator® Cutoff.....B1—B30

- Separator® Classic Inserts
- Separator® F<sup>2</sup> Inserts
- Separator® G<sup>2</sup> Inserts
- Separator® S<sup>2</sup> Inserts
- Separator® S<sup>2</sup>-Ultra Inserts
- Separator® X<sup>2</sup> Inserts
- Separator® X<sup>2</sup>-Ultra Inserts
- Separator® D<sup>2</sup> Inserts
- Separator® GT Inserts
- Separator® PL Inserts
- Separator® Quattro™ Inserts & Toolholders
- Quattro™ Toolholders
- Separator® Toolholders



Chipmaker® O.D. & I.D. Grooving .....C1—C28

- Chipmaker® Inserts
- O.D. Grooving Inserts & Toolholders
- TGT Toolholders
- Chipmaker® 95 Inserts
- I.D. Grooving Replaceable End Toolholders
- S-LOC™ Inserts & Toolholders
- O.D./I.D. Groovindex® Inserts & Toolholders



Ranger™ Face Grooving.....D1—D20

- Ranger™ Toolholders & Inserts
- Small Diameter Face Grooving Toolholders & Inserts
- S-LOC™ Toolholders & Inserts
- Groovindex® Inserts & Toolholders
- Chipmaker® Inserts
- Chipmaker® 95 Inserts



Octicut® Threading .....E1—E6

- Octicut® Threading Inserts
- Miniature Series External Toolholders
- Adjustable Helix Threading System
- S-LOC™ Inserts & Toolholders

Manchester Technical Information .....F1—F16

Product/Page Index.....G1—G9

# RANGER™

2-1/4" O.D. To 16" O.D. (57mm O.D. TO 400mm O.D.)

Range With One Assembly

## ROUND SHANK TOOLHOLDER

(Inch & Metric)

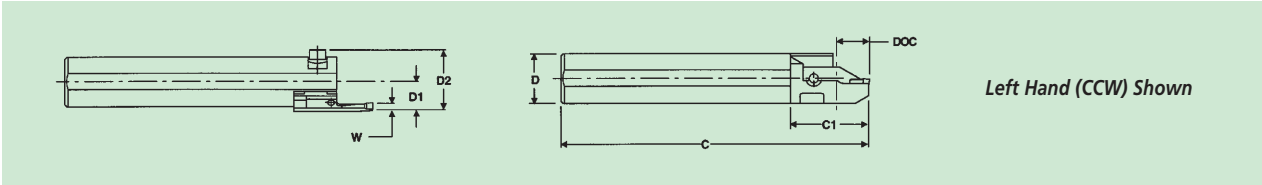

Left Hand (CCW) Shown

## SQUARE RIGHT ANGLE SHANK HOLDER

(Inch & Metric)

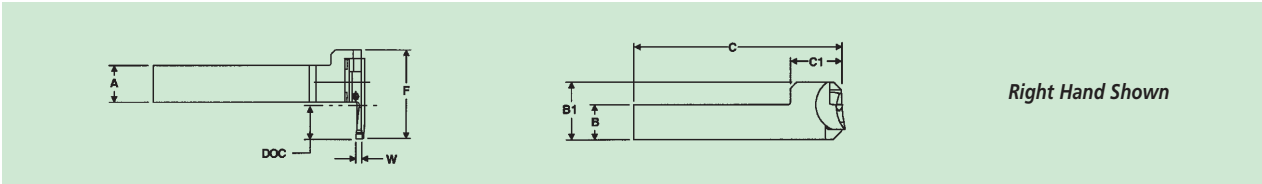

Right Hand Shown

## THE RANGER™

Adjustable Face Grooving

2-1/4" O.D. to 16" O.D. with One Assembly

Blade Style	Part Shape		Rotation	Shank	Holder Style	
					Round	Square
A			CCW	RH		
B			CW	LH		
C			CCW	LH		
D			CW	RH		

# RANGER™

## Inch Shank Toolholders

Ranger™ Toolholders													INCH	
Blade Style	Rotation	Part No.	Shank		A	B	B <sub>1</sub>	C	C <sub>1</sub>	D	D <sub>1</sub>	D <sub>2</sub>	F	
			Style	Hand										
A,B,C,D	CCW	CW	235-110	Round	LH/RH	—	—	—	9.00	2.31	1.00	.80	1.78	—
A,B,C,D	CCW	CW	235-109	Round	LH/RH	—	—	—	9.00	2.31	1.25	.80	1.78	—
A,B,C,D	CCW	CW	235-101	Round	LH/RH	—	—	—	9.00	2.31	1.50	.80	1.78	—
C	CCW		235-103	Sq. Rt. Angle	LH	1.06	.75	1.96	6.00	1.87	—	—	—	2.56
C	CCW		235-104	Sq. Rt. Angle	LH	1.06	1.00	1.96	6.00	1.87	—	—	—	2.56
C	CCW		235-105	Sq. Rt. Angle	LH	1.06	1.25	1.96	6.00	1.87	—	—	—	2.56
D	CW		235-106	Sq. Rt. Angle	RH	1.06	.75	1.96	6.00	1.87	—	—	—	2.56
D	CW		235-107	Sq. Rt. Angle	RH	1.06	1.00	1.96	6.00	1.87	—	—	—	2.56
D	CW		235-108	Sq. Rt. Angle	RH	1.06	1.25	1.96	6.00	1.87	—	—	—	2.56

See components below and page D5 for inserts.

**NOTE:** Toolholders supplied with support blade screw.

### Components INCH

Blade Style	Rotation	Hand	W	DOC	Cartridge Part No.
A	CCW	RH	.126	.75	338-121
A	CCW	RH	.188	1.00	338-122
A	CCW	RH	.250	1.00	338-131
B	CW	LH	.126	.75	338-123
B	CW	LH	.188	1.00	338-124
B	CW	LH	.250	1.00	338-132
C	CCW	LH	.126	.75	338-125
C	CCW	LH	.188	1.00	338-126
C	CCW	LH	.250	1.00	338-127
D	CW	RH	.126	.75	338-128
D	CW	RH	.188	1.00	338-129
D	CW	RH	.250	1.00	338-130

**NOTE:** Cartridges are supplied complete with clamp and clamp screw.

### Replacement Hardware INCH

Shank Style	Round	Square
Support Blade Screw	619-155	606-218
Clamp Screw	606-219	606-219
Washer	613-135	—
Nut	—	613-137

# RANGER™

## Metric Shank Toolholders

### Ranger™ Toolholders

**METRIC**

Blade Style	Rotation	Part No.	Shank		A	B	B <sub>1</sub>	C	C <sub>1</sub>	D	D <sub>1</sub>	D <sub>2</sub>	F
			Style	Hand									
A,B,C,D	CCW CW	235-201	Round	LH/RH	—	—	—	200	62	25	20.3	45.2	—
A,B,C,D	CCW CW	235-202	Round	LH/RH	—	—	—	200	62	30	20.3	45.2	—
A,B,C,D	CCW CW	235-203	Round	LH/RH	—	—	—	200	62	32	20.3	45.2	—
C	CCW	235-204	Sq. Rt. Angle	LH	27	20	49	152	46	—	—	—	65
C	CCW	235-205	Sq. Rt. Angle	LH	27	25	49	152	46	—	—	—	65
C	CCW	235-206	Sq. Rt. Angle	LH	27	32	49	152	46	—	—	—	65
D	CW	235-207	Sq. Rt. Angle	RH	27	20	49	152	46	—	—	—	65
D	CW	235-208	Sq. Rt. Angle	RH	27	25	49	152	46	—	—	—	65
D	CW	235-209	Sq. Rt. Angle	RH	27	32	49	152	46	—	—	—	65

See components below and page D5 for inserts.

**NOTE:** Toolholders supplied with support blade screw.

### Components

**METRIC**

Blade Style	Rotation	Hand	W	DOC	Cartridge Part No.
A	CCW	RH	3.2	19	338-221
A	CCW	RH	4.8	25	338-222
A	CCW	RH	6.35	25	338-231
B	CW	LH	3.2	19	338-223
B	CW	LH	4.8	25	338-224
B	CW	LH	6.35	25	338-232
C	CCW	LH	3.2	19	338-225
C	CCW	LH	4.8	25	338-226
C	CCW	LH	6.35	25	338-227
D	CW	RH	3.2	19	338-228
D	CW	RH	4.8	25	338-229
D	CW	RH	6.35	25	338-230

**NOTE:** Cartridges are supplied complete with clamp and clamp screw.

### Replacement Hardware

**METRIC**

Shank Style	Round	Square
Support Blade Screw	619-155	606-218
Clamp Screw	606-219	606-219
Washer	613-135	—
Nut	—	613-137

# Ranger™ Inserts

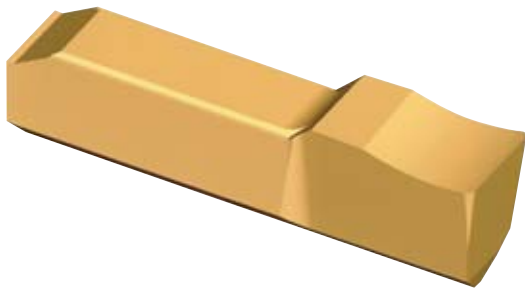
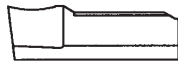
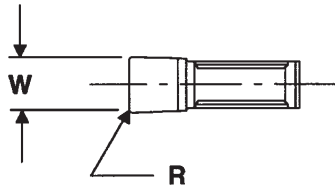

Ranger™ Inserts				INCH
Blade Style	Rotation	W	R	Insert Part No.
A,C	CCW	.126	.010	506-101
A,C	CCW	.126	.010	526-101
A,C	CCW	.126	FNR	506-104
A,C	CCW	.126	FNR	526-104
B,D	CW	.126	.010	506-102
B,D	CW	.126	.010	526-102
B,D	CW	.126	FNR	506-105
B,D	CW	.126	FNR	526-105
A,B,C,D	CCW CW	.188	.010	506-103
A,B,C,D	CCW CW	.188	.010	526-103
A,B,C,D	CCW CW	.188	FNR	506-106
A,B,C,D	CCW CW	.188	FNR	526-106
A,B,C,D	CCW CW	.250	.010	506-107
A,B,C,D	CCW CW	.250	FNR	506-108

Ranger™ 506 Series Inserts are available in Uncoated (C2 and C5), TiN (M40), TiAlN (M43) and Al<sub>2</sub>O<sub>3</sub> (M24). 526 Series Inserts are available in CBN (CBNHT and CBNCI) grades only.

See Section A – MTC™ Products for additional Face Grooving tools.

## SMALL DIAMETER FACE GROOVING

1-1/4" O.D. to 3-1/2" O.D.

Square Shank Toolholder



## SMALL DIAMETER FACE GROOVING

1-1/4" O.D. to 3-1/2" O.D.

Right Angle Toolholder

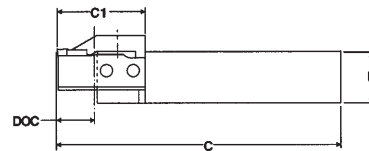
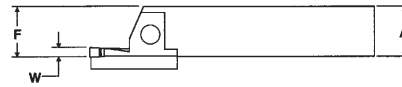

Right Hand Shown

### 1-1/4" O.D. to 3-1/2" O.D. Square Shank Toolholder

INCH

Counter Clockwise Left Hand	A	B	C	C <sub>1</sub>	F	Clockwise Right Hand
203-347	1.00	.75	5.00	1.72	1.00	203-347
203-351	1.00	1.00	6.00	1.72	1.00	203-350

See page D7 for components and page D8 for inserts.

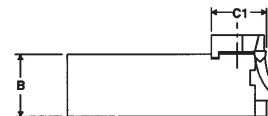
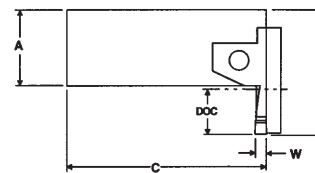

Right Hand Shown

### 1-1/4" O.D. to 3-1/2" O.D. Right Angle Toolholder

INCH

Counter Clockwise Left Hand	A	B	C	C <sub>1</sub>	F	Clockwise Right Hand
204-266	1.12	.75	4.50	.87	1.90	204-266
204-268	1.12	1.00	6.00	.87	2.00	204-267

**NOTE:** All toolholders designed to position inserts .050" above machine centerline which will limit tool's ability to turn smaller than 15/16" diameter.

See page D7 for components and page D8 for inserts.

# SMALL DIAMETER FACE GROOVING

1-1/4" O.D. to 3-1/2" O.D.

Round Shank Toolholder

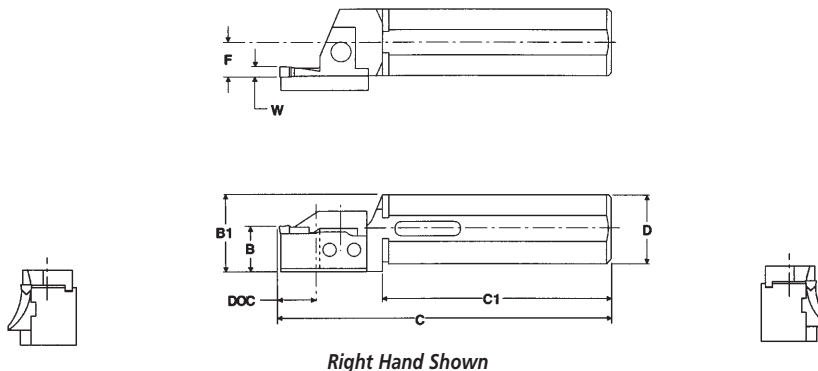

1-1/4" O.D. to 3-1/2" O.D. Round Shank Toolholder							INCH
Counter Clockwise Left Hand	B	B <sub>1</sub>	C	C <sub>1</sub>	D	F	Clockwise Right Hand
203-349	.75	1.34	6.50	4.50	1.25	.62	203-348

**NOTE:** All toolholders designed to position inserts .050" above machine centerline which will limit tool's ability to turn smaller than 15/16" diameter. See pages D8 for inserts.

Components for Small Diameter Face Grooving							INCH
Major O.D. Range	W	Counter Clockwise Left Hand			Clockwise Right Hand		
		Support Blade*	Clamp	DOC	Clamp	Support Blade*	
1.25-1.50	.126	334-101	436-101	.500	436-103	334-111	
1.50-1.87	.126	334-102	436-101	.500	436-103	334-112	
1.87-2.50	.126	334-103	436-101	.750	436-103	334-113	
	.188	334-107	436-102	.750	436-104	334-117	
2.50-3.50	.126	334-104	436-101	.750	436-103	334-114	
	.188	334-108	436-102	.750	436-104	334-118	

\*Support blades must be cleared for FNR inserts.

Replacement Hardware		INCH
Support Blade Screws	Clamp Screw	
606-167	619-147	

See Section A – MTC™ Products for additional Face Grooving tools.

# SMALL DIAMETER FACE GROOVING

## Inserts

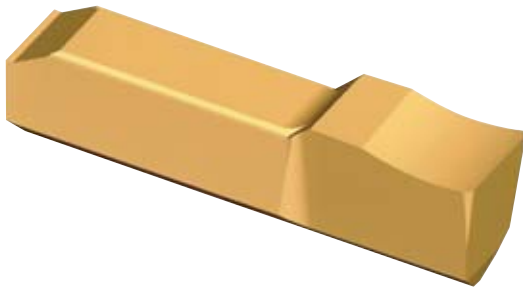
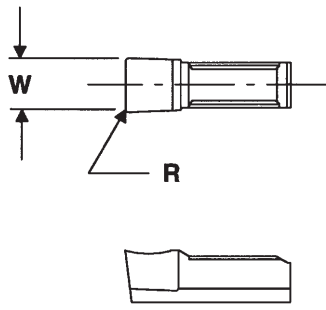

Small Diameter Face Grooving Inserts			INCH
Rotation	W	R	Insert Part No.
CCW(LH)	.126	.010	506-101
CCW(LH)	.126	.010	526-101
CCW(LH)	.126	FNR	506-104
CCW(LH)	.126	FNR	526-104
CW(RH)	.126	.010	506-102
CW(RH)	.126	.010	526-102
CW(RH)	.126	FNR	506-105
CW(RH)	.126	FNR	526-105
CCW(LH) CW(RH)	.188	.010	506-103
CCW(LH) CW(RH)	.188	.010	526-103
CCW(LH) CW(RH)	.188	FNR	506-106
CCW(LH) CW(RH)	.188	FNR	526-106

Small Diameter Face Grooving 506 Series Inserts are available in Uncoated (C2 and C5), TiN+TiC+TiN (GC), TiN (M40), TiAlN (M43) and Al<sub>2</sub>O<sub>3</sub> (M24). 526 Series Inserts are available in CBN (CBNHT and CBNCI) grades only.

See Section A – MTC™ Products for additional Face Grooving tools.

# FACE GROOVING

1/2" and Larger O.D.

S-LOC™ Toolholders

# FACE GROOVING

S-LOC™ Inserts

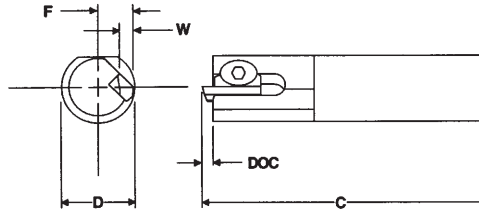

Right Hand Shown

## 1/2" and Larger O.D. S-LOC™ Toolholders

**INCH**

Counter Clockwise Left Hand	DOC	C	D	F	Clockwise Right Hand
218-126	.094	6.00	.625	.250	218-125

NOTE: Toolholders will not enter a bore and groove at bore diameter.

## Replacement Hardware

**INCH**

Locking Clamp Screw

606-190

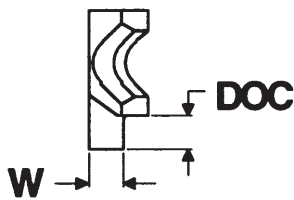

Left Hand Shown

## Face Grooving S-LOC™ Inserts

**INCH**

Counter Clockwise Left Hand Part No.	W	DOC	Clockwise Right Hand Part No.
510-135	.078	.094	510-136
510-107	.094	.094	510-108
510-137	.102	.094	510-138

Face Grooving S-LOC™ Inserts are available in Uncoated (C2 and C5), and TiN (M40).

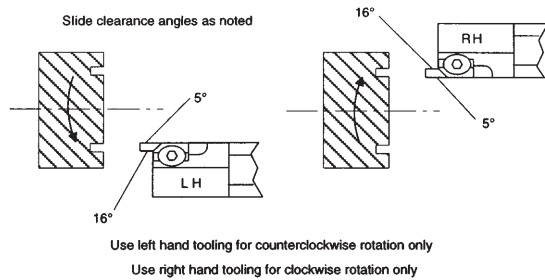

# GROOVIDEX® GROOVING INSERTS

## Face Grooving

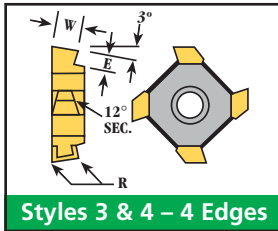
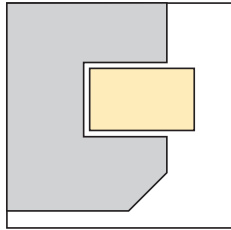

Styles 3 & 4 – 4 Edges

Right Hand Shown

### Face Grooving Inserts

INCH

Left Hand MTC No.	Width	Dimensions IC	W	E	R	Style	Right Hand MTC No.
571-125	0.062	7/16	0.062	0.125	0.008	3	571-137
571-127	0.094	7/16	0.094	0.125	0.008	3	571-140
571-129	0.125	7/16	0.125	0.125	0.008	3	571-142
571-198	0.094	9/16	0.094	0.180	0.010	4	571-176
571-158	0.125	9/16	0.125	0.180	0.010	4	571-204
571-165	0.188	9/16	0.188	0.190	0.020	4	571-206

**NOTE:** Right hand inserts are for clockwise rotating parts and left hand inserts are to be used on counter clockwise rotating parts. The minimum outside groove diameter for standard Style 3 inserts is 1.000". For Style 4 inserts, the minimum outside groove diameter is 1.375". Standard inserts may be modified to clear smaller outside diameters upon request.

Face Grooving Inserts are available in TiN (M40), TiCN (M45), TiN (M50) and TiAlN (M93).

See Section A – MTC™ Products for additional Face Grooving tools.

# GROOVIDEX® FACE GROOVING

External Toolholders

Fixed Pocket

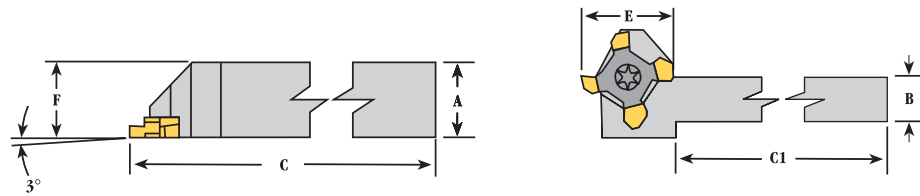

Right Hand Shown

## External Grooving Fixed Pocket

**INCH**

Left Hand MTC No.	A	B	C	C <sub>1</sub>	E	F	Insert Style	Right Hand MTC No.
245-202	0.37	3/8	4	3.23	3/4	3/8	3	245-201
245-204	0.49	1/2	5	—	3/4	1/2	3	245-203
245-206	0.62	5/8	5	—	3/4	5/8	3	245-205
245-208	0.74	3/4	5	—	3/4	3/4	3	245-207
245-210	0.99	1	6	—	3/4	1	3	245-209
245-214	0.62	5/8	5	—	1	5/8	4	245-213
245-216	0.74	3/4	5	—	1	3/4	4	245-215
245-218	0.99	1	6	—	1	1	4	245-217

## External Grooving Fixed Pocket

**METRIC**

Left Hand MTC No.	A mm	B mm	C mm	C <sub>1</sub> mm	E mm	F mm	Insert Style	Right Hand MTC No.
245-302	9.8	10	100	80.4	19	10	3	245-301
245-304	11.7	12	125	—	19	12	3	245-303
245-306	15.7	16	125	—	19	16	3	245-305
245-308	19.7	20	125	—	19	20	3	245-307
245-310	24.7	25	150	—	19	25	3	245-309
245-316	19.7	20	125	—	25.4	20	4	245-315
245-318	24.7	25	150	—	25.4	25	4	245-317

**NOTE:** Holder supplied with screw, less insert.  
See page D10 for inserts.

## Replacement Hardware

**INCH / METRIC**

Insert Screw	Wrench	Insert Style
644-107	644-110	3
644-108	644-111	4

# GROOVIDEX® FACE GROOVING

External Toolholders

Angle Head Style

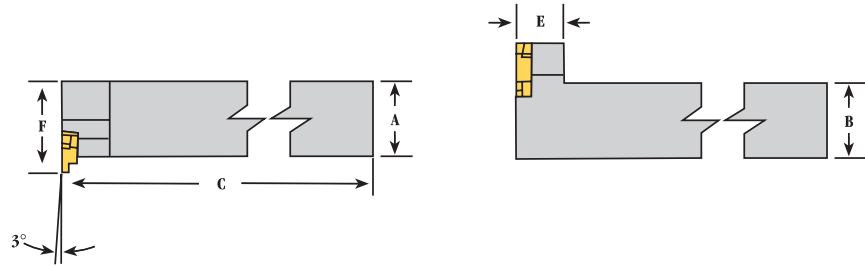

Left Hand Shown

## External Type Angle Head Style

**INCH**

Left Hand MTC No.	A	B	C	E	F	Insert Style	Right Hand MTC No.
245-222	0.63	5/8	5	1/2	0.78	3	245-221
245-224	0.75	3/4	5	1/2	0.91	3	245-223
245-226	1.00	1	6	1/2	1.16	3	245-225
245-230	0.82	5/8	5	5/8	1.03	4	245-229
245-232	0.82	3/4	5	5/8	1.03	4	245-231
245-234	1.01	1	6	5/8	1.22	4	245-233

## External Type Angle Head Style

**METRIC**

Left Hand MTC No.	A mm	B mm	C mm	E mm	F mm	Insert Style	Right Hand MTC No.
245-324	20	20	125	12.7	24	3	245-323
245-326	25	25	150	12.7	29	3	245-325
245-332	20.7	20	125	15.9	26	4	245-331
245-334	25	25	150	15.9	30.3	4	245-333

**NOTE:** Holder supplied with screw, less insert.  
See page D10 for inserts.

## Replacement Hardware

**INCH / METRIC**

Insert Screw	Wrench	Insert Style
644-107	644-110	3
644-108	644-111	4

# FACE GROOVING

3" and Larger O.D.

Square Shank

13/16" Depth of Cut

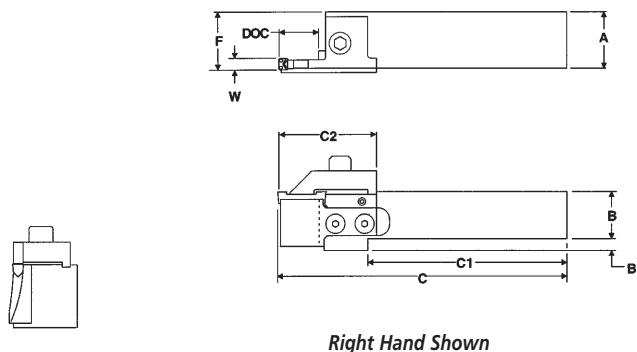

Right Hand Shown

## Square Shank – 13/16" Depth of Cut

INCH

Counter Clockwise Left Hand	DOC	A	B	B <sub>1</sub>	C	C <sub>1</sub>	C <sub>2</sub>	F*	Clockwise Right Hand
203-352	13/16	1.199	1.00	.250	6.19	4.25	2.125	1.250	203-287
203-271	13/16	1.449	1.25	—	5.94	—	2.125	1.500	—
—	13/16	1.199	1.25	—	6.69	—	2.125	1.250	203-245
203-232	13/16	1.449	1.25	—	6.19	—	2.125	1.500	203-231
203-233	13/16	1.949	1.50	—	6.69	—	2.125	2.000	203-112

\*"F" dimension shown is over handed insert.  
See pages D18 and D19 for inserts.

## Components

INCH

O.D. Range	W	Counter Clockwise Left Hand			Clockwise Right Hand	
		Support Blade*	Clamp	Stop	Clamp	Support Blade*
3-4	.250	327-148	430-108	601-129	430-111	327-160
	.312	327-152	430-109	601-130	430-112	327-164
4-6	.250	327-149	430-108	601-129	430-111	327-161
	.312	327-153	430-109	601-130	430-112	327-165
6-12	.250	327-150	430-108	601-129	430-111	327-162
	.312	327-154	430-109	601-130	430-112	327-166
12-18	.250	327-151	430-108	601-129	430-111	327-163
	.312	327-155	430-109	601-130	430-112	327-167
18 & Up	.250	327-209	430-108	601-129	430-111	327-208
	.312	327-155	430-109	601-130	430-112	327-167

\*Support blades must be cleared for FNR inserts.

## Replacement Hardware

INCH

Support Blade Screws	Clamp Screw	Stop Screw
606-160	619-110	619-101

See Section A – MTC™ Products for additional Face Grooving tools.

# FACE GROOVING

70mm and Larger O.D.

Square Shank

20.6mm Depth of Cut

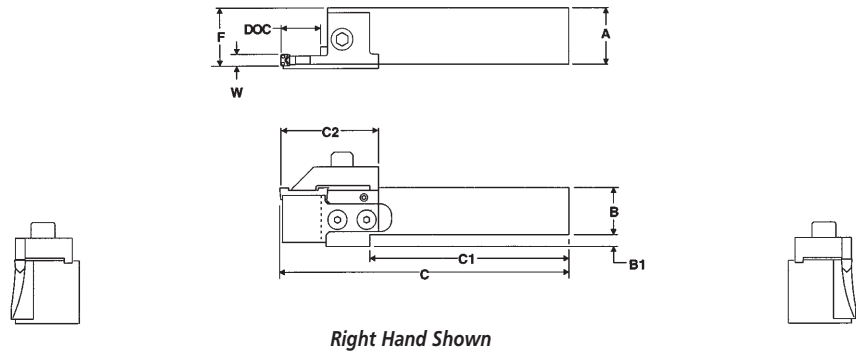

Right Hand Shown

## Square Shank – 20.6mm Depth of Cut

**METRIC**

Counter Clockwise Left Hand	DOC	A	B	B <sub>1</sub>	C	C <sub>1</sub>	C <sub>2</sub>	F	Clockwise Right Hand
203-354	20.6	32	25	7	189	123	54	33	203-353
203-356	20.6	32	32	—	209	—	54	33	203-355

Toolholders supplied without support blade and clamp.  
See pages D18 and D19 for inserts.

## Components

**METRIC**

O.D. Range	W	Counter Clockwise Left Hand			Clockwise Right Hand	
		Support Blade	Clamp	Stop	Clamp	Support Blade
70-100	6	327-148	430-108	601-129	430-111	327-160
	8	327-152	430-109	601-130	430-112	327-164
100-150	6	327-149	430-108	601-129	430-111	327-161
	8	327-153	430-109	601-130	430-112	327-165
150-300	6	327-150	430-108	601-129	430-111	327-162
	8	327-154	430-109	601-130	430-112	327-166
300-450	6	327-151	430-108	601-129	430-111	327-163
	8	327-155	430-109	601-130	430-112	327-167
450 & Up	6	327-209	430-108	601-129	430-111	327-208
	8	327-155	430-109	601-130	430-112	327-167

## Replacement Hardware

**METRIC**

Support Blade Screws	Clamp Screw	Stop Screw
606-222	619-161	619-162

# FACE GROOVING

## Right Angle Toolholders

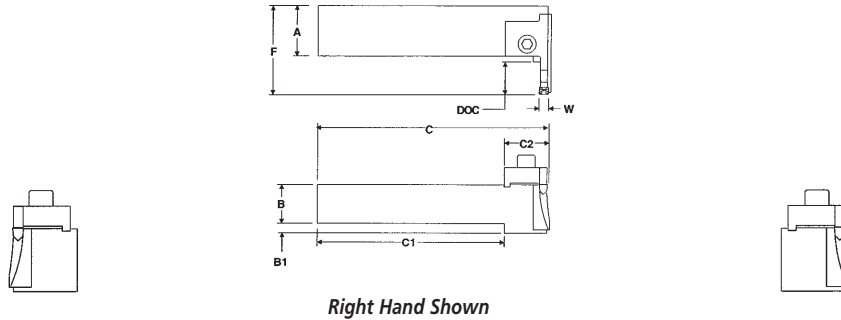

Right Angle Toolholders									<i>INCH</i>	
Counter Clockwise Left Hand	DOC	A	B	B <sub>1</sub>	C	C <sub>1</sub>	C <sub>2</sub>	F*	Clockwise Right Hand	
204-270	13/16	1.312	1.00	.250	6.00	4.85	1.140	2.313	204-269	
204-215	13/16	1.312	1.25	—	6.00	—	1.140	2.313	204-214	
204-259	13/16	1.500	1.50	—	6.00	—	1.140	2.500	204-258	

\*"F" dimension shown is over handed insert.  
See pages D18 and D19 for inserts.

Components							<i>INCH</i>
O.D.Range	W	Counter Clockwise Left Hand			Clockwise Right Hand		
		Support Blade*	Clamp	Stop	Clamp	Support Blade*	
3-4	.250	327-148	430-108	601-129	430-111	327-160	
	.312	327-152	430-109	601-130	430-112	327-164	
4-6	.250	327-149	430-108	601-129	430-111	327-161	
	.312	327-153	430-109	601-130	430-112	327-165	
6-12	.250	327-150	430-108	601-129	430-111	327-162	
	.312	327-154	430-109	601-130	430-112	327-166	
12-18	.250	327-151	430-108	601-129	430-111	327-163	
	.312	327-155	430-109	601-130	430-112	327-167	
18 & Up	.250	327-209	430-108	601-129	430-111	327-208	
	.312	327-155	430-109	601-130	430-112	327-167	

\*Support blades must be cleared for FNR inserts.

Replacement Hardware			<i>INCH</i>
Support Blade Screws	Clamp Screw	Stop Screw	
606-160	619-110	619-101	

See Section A – MTC™ Products for additional Face Grooving tools.

# FACE GROOVING

## Right Angle Toolholders

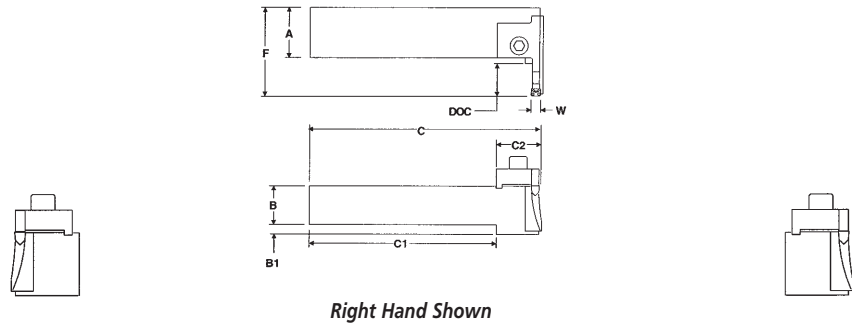

### Right Angle Toolholders

**METRIC**

Counter Clockwise Left Hand	DOC	A	B	B <sub>1</sub>	C	C <sub>1</sub>	C <sub>2</sub>	F	Clockwise Right Hand
204-272	20.6	35	25	7	166	137	29	59	204-271
204-274	20.6	35	32	—	166	—	29	59	204-273

*Toolholders supplied without support blade and clamp.  
See pages D18 and D19 for inserts.*

### Components

**METRIC**

O.D.Range	W	Counter Clockwise Left Hand			Clockwise Right Hand	
		Support Blade	Clamp	Stop	Clamp	Support Blade
70-100	6	327-148	430-108	601-129	430-111	327-160
	8	327-152	430-109	601-130	430-112	327-164
100-150	6	327-149	430-108	601-129	430-111	327-161
	8	327-153	430-109	601-130	430-112	327-165
150-300	6	327-150	430-108	601-129	430-111	327-162
	8	327-154	430-109	601-130	430-112	327-166
300-450	6	327-151	430-108	601-129	430-111	327-163
	8	327-155	430-109	601-130	430-112	327-167
450 & Up	6	327-209	430-108	601-129	430-111	327-208
	8	327-155	430-109	601-130	430-112	327-167

### Replacement Hardware

**METRIC**

Support Blade Screws	Clamp Screw	Stop Screw
606-222	619-161	619-162

# FACE GROOVING

## Round Shank Toolholders

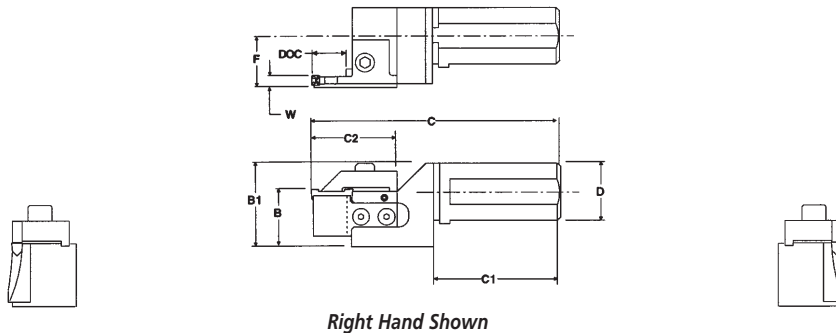

### Round Shank Toolholders

**INCH**

Counter Clockwise Left Hand	DOC	D	B	B <sub>1</sub>	C	C <sub>1</sub>	C <sub>2</sub>	F*	Clockwise Right Hand
203-335	13/16	2.00	1.43	2.37	10.00	7.00	1.140	1.200	203-336
203-340	13/16	1.50	1.43	2.15	9.75	7.00	1.140	1.000	203-341

\*"F" dimension shown is over handed insert.  
See pages D18 and D19 for inserts.

### Components

**INCH**

O.D.Range	W	Counter Clockwise Left Hand			Clockwise Right Hand	
		Support Blade*	Clamp	Stop	Clamp	Support Blade*
3-4	.250	327-148	430-108	601-129	430-111	327-160
	.312	327-152	430-109	601-130	430-112	327-164
4-6	.250	327-149	430-108	601-129	430-111	327-161
	.312	327-153	430-109	601-130	430-112	327-165
6-12	.250	327-150	430-108	601-129	430-111	327-162
	.312	327-154	430-109	601-130	430-112	327-166
12-18	.250	327-151	430-108	601-129	430-111	327-163
	.312	327-155	430-109	601-130	430-112	327-167
18 & Up	.250	327-209	430-108	601-129	430-111	327-208
	.312	327-155	430-109	601-130	430-112	327-167

\*Support blades must be cleared for FNR inserts.

### Replacement Hardware

**INCH**

Support Blade Screws	Clamp Screw	Stop Screw
606-160	619-110	619-101

See Section A – MTC™ Products for additional Face Grooving tools.

# FACE GROOVING

Chipmaker® Inserts

# FACE GROOVING

Chipmaker® 95 Inserts

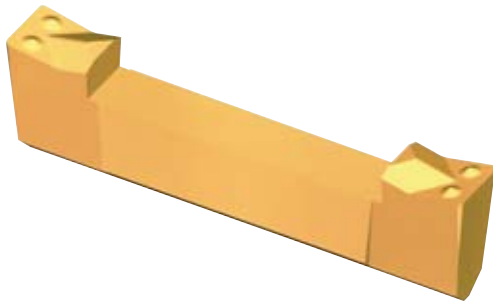
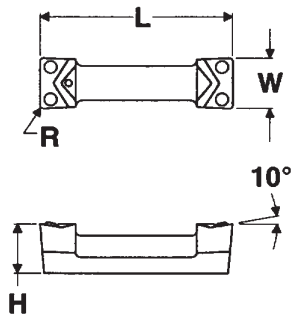

## Chipmaker® Inserts INCH

Part Number	W	L	R	H
508-240	.250	1.0	.010	1/4
508-247	.250	1.0	.030	1/4
508-242	.312	1-1/8	.010	11/32
508-248	.312	1-1/8	.030	11/32

## Chipmaker® Inserts METRIC

Part Number	W mm	L mm	R mm	H mm
508-262	6	25.4	0.3	6.35
508-263	6	25.4	0.6	6.35
508-279	8	28.6	0.3	8.70
508-280	8	28.6	0.6	8.70

Chipmaker® Inserts are available in TiN (M40), TiAlN (M43), TiCN (M45), TiN (M50) & TiAlN (M93).

See pages D13-D17 for Holders.

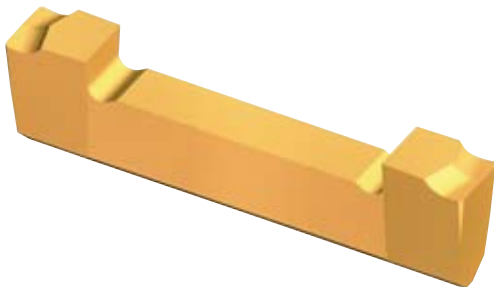
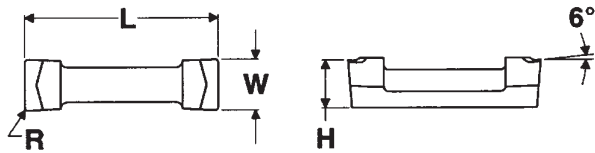

## Chipmaker® 95 Inserts INCH

Part Number	W	L	R	H
508-422	.250	1.0	.010	1/4
508-423	.250	1.0	.030	1/4
508-424	.250	1.0	.060	1/4

## Chipmaker® 95 Inserts METRIC

Part Number	W mm	L mm	R mm	H mm
508-435	8	1-1/8	.030	11/32
508-436	8	1-1/8	.060	11/32

Chipmaker® 95 Inserts are available in TiN (M40) & TiAlN (M53).

See pages D13-D17 for Holders.

## FACE GROOVING

Central Neutral Rake Inserts (O.D.)

## FACE GROOVING

Central Positive Rake Inserts (O.D.)

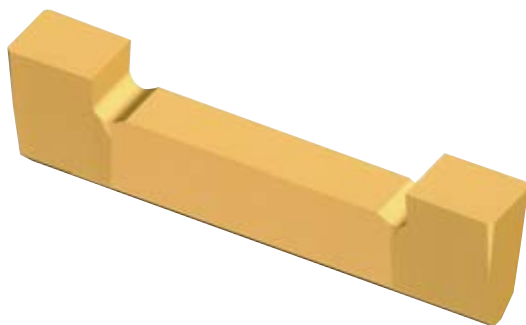
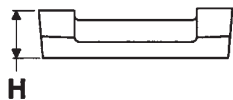
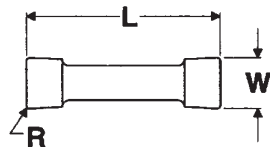

### Central Neutral Rake Inserts

**INCH**

Part Number	W	L	R	H
508-310	.250	1.0	.030	1/4
508-340	.250	1.0	.060	1/4
508-316	.250	1.0	FNR	1/4
508-305	.312	1-1/8	.010	11/32
508-311	.312	1-1/8	.030	11/32
508-341	.312	1-1/8	.060	11/32
508-317	.312	1-1/8	FNR	11/32

### Central Neutral Rake Inserts

**METRIC**

Part Number	W mm	L mm	R mm	H mm
508-456	6	25.4	0.3	6.35
508-457	6	25.4	0.6	6.35
508-458	6	25.4	FNR	6.35

Central Neutral Rake Inserts are available in Uncoated (C2 & C5), TiN+TiC+TiN (GC) & Al<sub>2</sub>O<sub>3</sub> (M24). Some inserts available in TiN (M40 & M50). FNR = Full Nose Radius.

See pages D13-D17 for Holders.

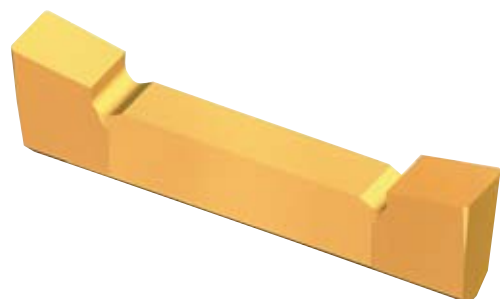
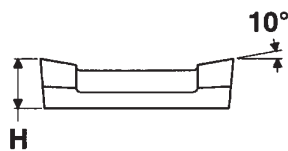
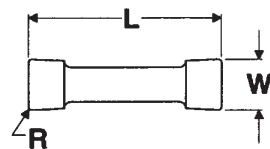

### Central Positive Rake Inserts

**INCH**

Part Number	W	L	R	H
508-322	.250	1.0	.010	1/4
508-328	.250	1.0	.030	1/4
508-334	.250	1.0	FNR	1/4
508-323	.312	1-1/8	.010	11/32
508-329	.312	1-1/8	.030	11/32
508-335	.312	1-1/8	FNR	11/32

### Central Positive Rake Inserts

**METRIC**

Part Number	W mm	L mm	R mm	H mm
508-470	6	25.4	0.3	6.35
508-471	6	25.4	0.6	6.35
508-472	6	25.4	FNR	6.35

Central Positive Rake Inserts are available in Uncoated (C2 & C5) & TiN+TiC+TiN (GC). Some inserts available in TiN (M40 & M50).

FNR = Full Nose Radius.

See pages D13-D17 for Holders.